

AIR BAG SCISSOR LIFT TABLE - ABLT-H-2-32

APPROX WEIGHT: 875.136 lbs.
 DOES NOT INCLUDE WEIGHT OF POWER OR PACKAGING!!!

ANY ADDITIONS, DELETIONS, OR OMISSIONS MUST BE CORRECTED ON THIS DRAWING AS THIS DRAWING WILL BE CONSIDERED ALL INCLUSIVE

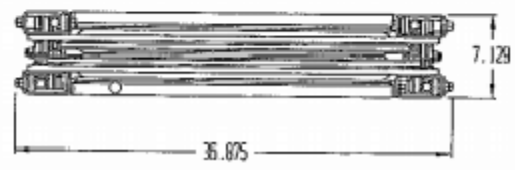
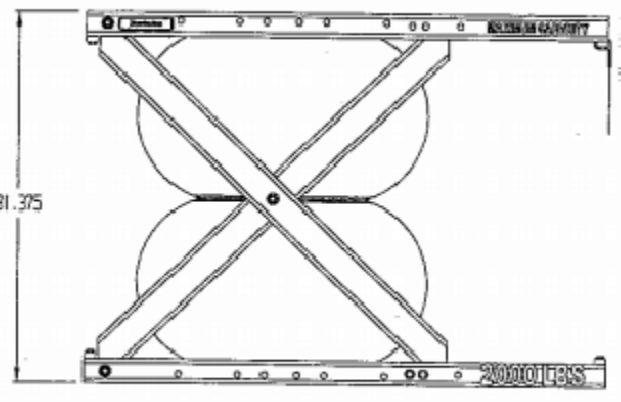
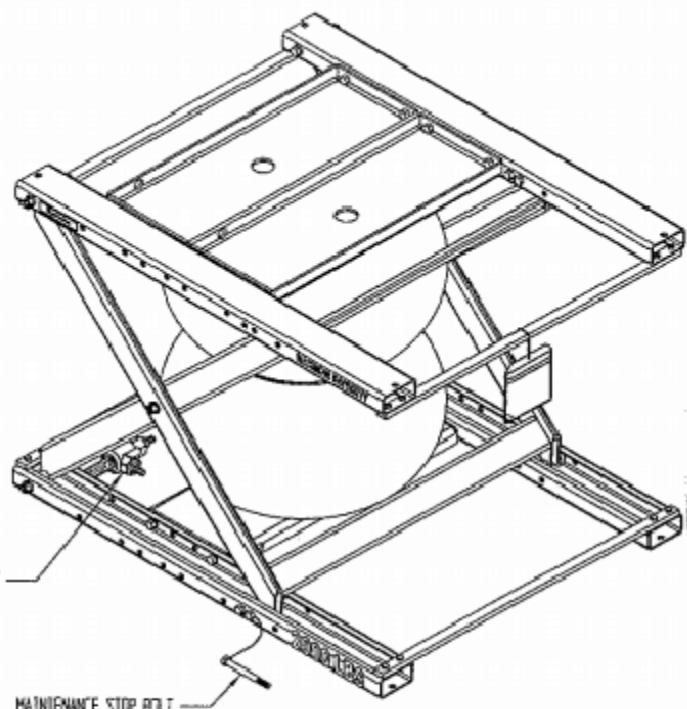
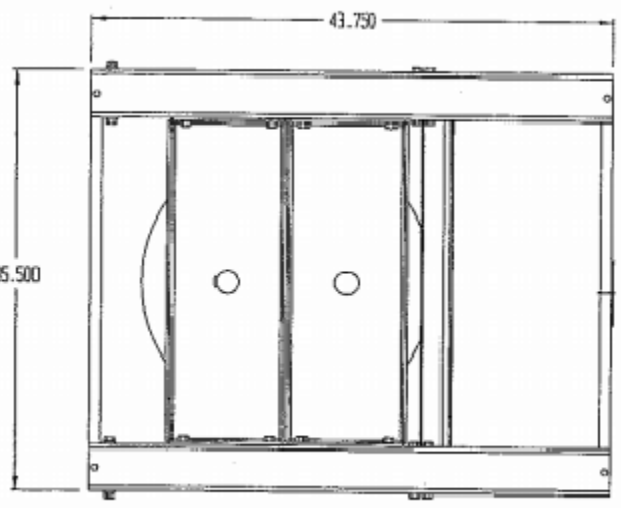

FOR INTERNAL USE ONLY PROJECT SIGN OFF	
SALES	
ENG.	
FAB.	
POWER	

ALL GRAPHICS PROVIDED ARE FOR REFERENCE ONLY. IF CERTAIN DIMENSIONS ARE CRITICAL PLEASE VERIFY THOSE DIMENSIONS WITH YOUR SALESPERSON

DIMENSION TOLERANCE ± 1/4"

STANDARD FEATURES

- MODEL NUMBER: ABLT-H-2-32
- CAPACITY: 2,000 LBS
- PLATFORM WIDTH: 35 1/2"
- PLATFORM LENGTH: 43 3/4"
- PLATFORM LOWERED HEIGHT: 7"
- PLATFORM RAISED HEIGHT: 32"
- AIR REQUIREMENT: 80 - 100 PSI @ 15 CFM
- STANDARD PRESSURE RELIEFT VALVE
- STANDARD MAINTENANCE STOPS

SPECIAL FEATURES

NONE

APPROVAL	I, THE UNDERSIGNED, AGREE THAT THE PRODUCT AS REPRESENTED SATISFIES DESIGN AND DIMENSION REQUIREMENTS. I ALSO ACKNOWLEDGE MY DUTY TO CONFIRM PRODUCT AND INSTALLATION COMPLIANCE WITH ALL APPLICABLE FEDERAL, STATE AND LOCAL REGULATIONS AND STANDARDS.	
	UNITS REQUIRING APPROVAL DRAWINGS OR MODIFIED ARE NON-RETURNABLE	
	[] As drawn [] As marked	
	Signed: _____	Date: _____
Printed Name: _____		
LEAD TIME WILL START UPON RECEIPT OF SIGNED APPROVAL DRAWING		

DISTRIBUTOR'S NAME:		P.O.#
VESTIL MANUFACTURING		X
DRAWN BY: KGH		W.O.#
DATE: 1/20/2017		X
REFERENCE: X	SCALE: 1:48	SALES: X
QUOTED LEAD TIME: X	QUOTE #	FILE NAME:
	X	ABLH-H-2-32