

ALUMINUM CHANNEL DOLLIES - ACP-2436-20-HDL

APPROX WEIGHT: 64.99 lbs.
DOES NOT INCLUDE WEIGHT OF POWER OR PACKAGING!!!

*** ANY ADDITIONS, DELETIONS, OR OMISSIONS MUST BE CORRECTED ON THIS DRAWING AS THIS DRAWING WILL BE CONSIDERED ALL INCLUSIVE ***

ALL GRAPHICS PROVIDED ARE FOR REFERENCE ONLY. IF CERTAIN DIMENSIONS ARE CRITICAL PLEASE VERIFY THOSE DIMENSIONS WITH YOUR SALESPERSON

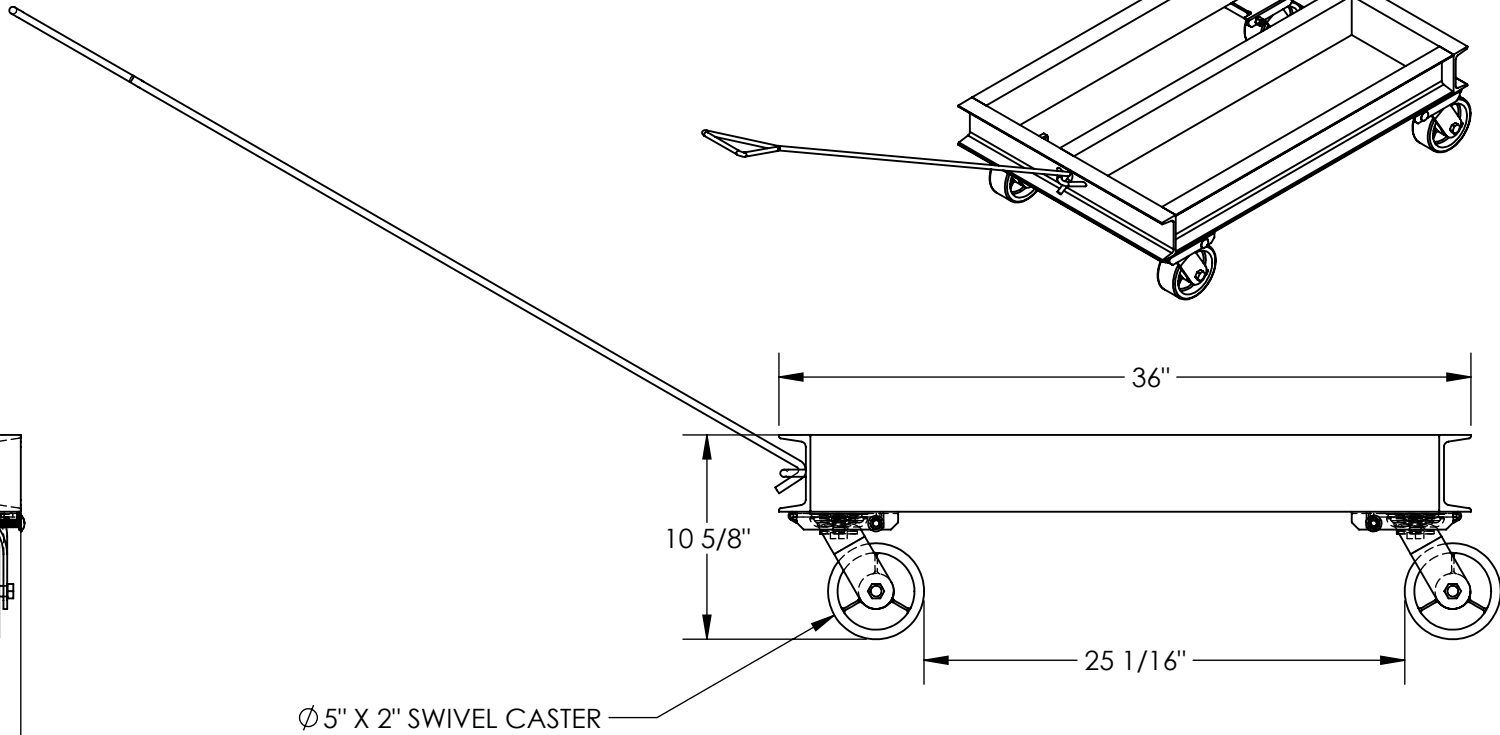
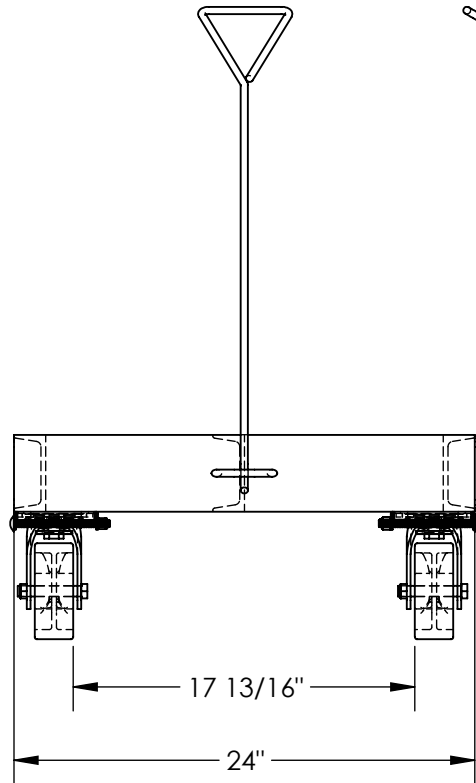

DIMENSION TOLERANCE ± 1/4"

STANDARD FEATURES

- MODEL NUMBER IS ACP-2436-20-HDL
- MAX CAPACITY IS 2,000 LBS
- OVERALL WIDTH IS 24"
- OVERALL LENGTH IS 36" WITHOUT HANDLE
- OVERALL HEIGHT IS 10 5/8"
- Ø5" X 2" POLY ON STEEL
- 4- SWIVEL CASTERS
- 4 FOOT DEATCHABLE HANDLE
- ALUMINUM CONSTRUCTION

SPECIAL FEATURES

NONE

APPROVAL

I, THE UNDERSIGNED, AGREE THAT THE PRODUCT AS REPRESENTED SATISFIES DESIGN AND DIMENSION REQUIREMENTS. I ALSO ACKNOWLEDGE MY DUTY TO CONFIRM PRODUCT AND INSTALLATION COMPLIANCE WITH ALL APPLICABLE FEDERAL, STATE AND LOCAL REGULATIONS AND STANDARDS.

UNITS REQUIRING APPROVAL DRAWINGS OR MODIFIED ARE NON-RETURNABLE

As drawn As marked

Signed: _____ Date: _____

Printed Name: _____

LEAD TIME WILL START UPON RECEIPT OF SIGNED APPROVAL DRAWING

DISTRIBUTOR'S NAME:		P.O.#
VESTIL MANUFACTURING		X
DRAWN BY: TCB	DATE: 12/15/2020	W.O.#
REFERENCE: X	SCALE: 1:10	X
QUOTED LEAD TIME: X	QUOTE #	SALES: X
	X	FILE NAME:
		16-007-521