

# ALUMINUM FOLDING HANDLE PLATFORM TRUCK - AFT-36-NM

\*\*\* ANY ADDITIONS, DELETIONS, OR OMISSIONS MUST BE CORRECTED ON THIS DRAWING AS THIS DRAWING WILL BE CONSIDERED ALL INCLUSIVE \*\*\*  
 ALL GRAPHICS PROVIDED ARE FOR REFERENCE ONLY. IF CERTAIN DIMENSIONS ARE CRITICAL PLEASE VERIFY THOSE DIMENSIONS WITH YOUR SALESPERSON

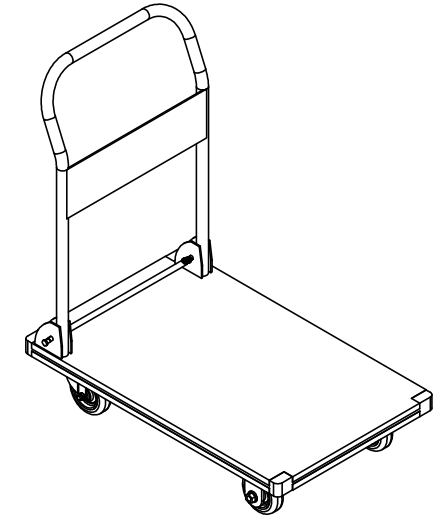
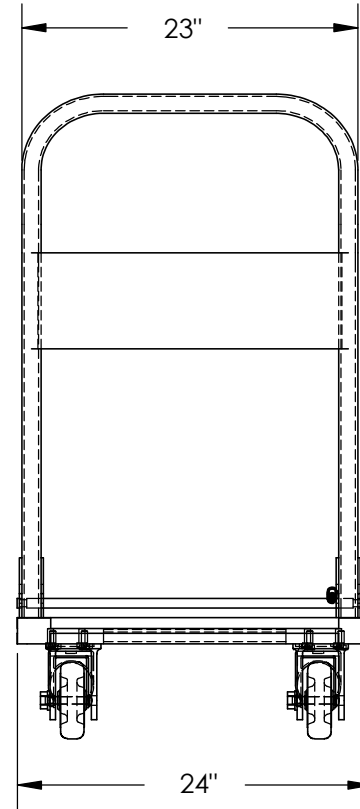
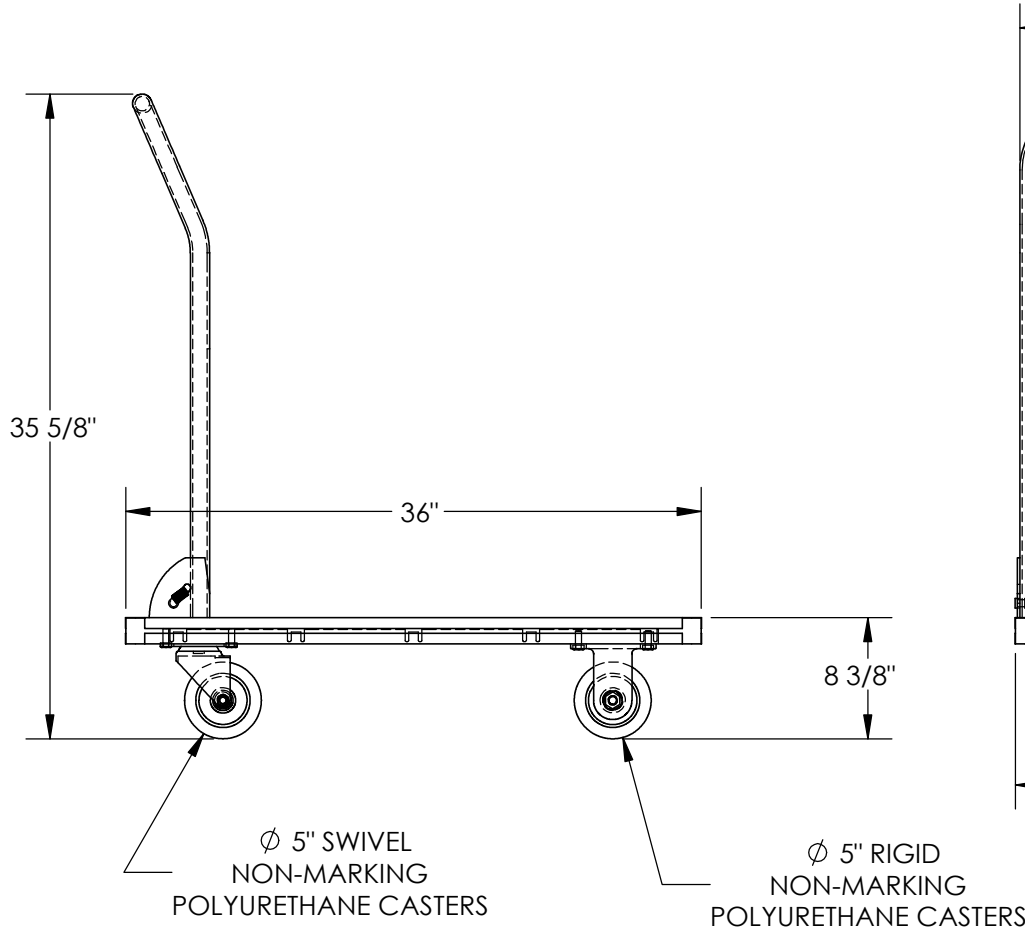

DIMENSION TOLERANCE  $\pm 1/4"$

## STANDARD FEATURES

MODEL NUMBER IS AFT-36-NM  
 OVERALL WIDTH IS 24"  
 USABLE WIDTH IS 24"  
 OVERALL LENGTH IS 36"  
 USABLE LENGTH IS 36"  
 OVERALL HEIGHT IS 35 5/8"  
 MAX CAPACITY IS 600 LBS.  
 APPROX. SHIPPING WEIGHT IS 36 LBS

## SPECIAL FEATURES

NONE

APPROVAL

I, THE UNDERSIGNED, AGREE THAT THE PRODUCT AS REPRESENTED SATISFIES DESIGN AND DIMENSION REQUIREMENTS. I ALSO ACKNOWLEDGE MY DUTY TO CONFIRM PRODUCT AND INSTALLATION COMPLIANCE WITH ALL APPLICABLE FEDERAL, STATE AND LOCAL REGULATIONS AND STANDARDS.  
**ALL SPECIAL UNITS ARE NON-RETURNABLE**  
 As drawn       As marked

Signed: \_\_\_\_\_ Date: \_\_\_\_\_

LEAD TIME WILL START UPON RECEIPT OF SIGNED APPROVAL DRAWING

DISTRIBUTOR'S NAME:		P.O.#
VESTIL MANUFACTURING		X
DRAWN BY: TM	DATE: 04/25/18	W.O.#
REFERENCE: X	SCALE: 1:10	X
QUOTED LEAD TIME: X	QUOTE #	SALES: X
	X	FILE NAME: AFT-36-NM