

ROTARY AIR/HYDRAULIC SCISSOR LIFT TABLE - AHLT-4848-3-43

APPROX WEIGHT: 681.36 lbs. DOES NOT INCLUDE WEIGHT OF POWER OR PACKAGING!!!

*** ANY ADDITIONS, DELETIONS, OR OMISSIONS MUST BE CORRECTED ON THIS DRAWING AS THIS DRAWING WILL BE CONSIDERED ALL INCLUSIVE ***

ALL GRAPHICS PROVIDED ARE FOR REFERENCE ONLY. IF CERTAIN DIMENSIONS ARE CRITICAL PLEASE VERIFY THOSE DIMENSIONS WITH YOUR SALESPERSON

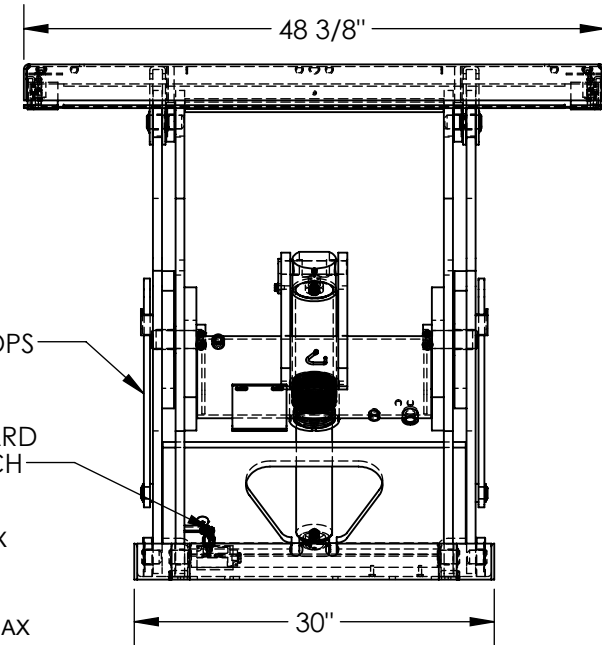
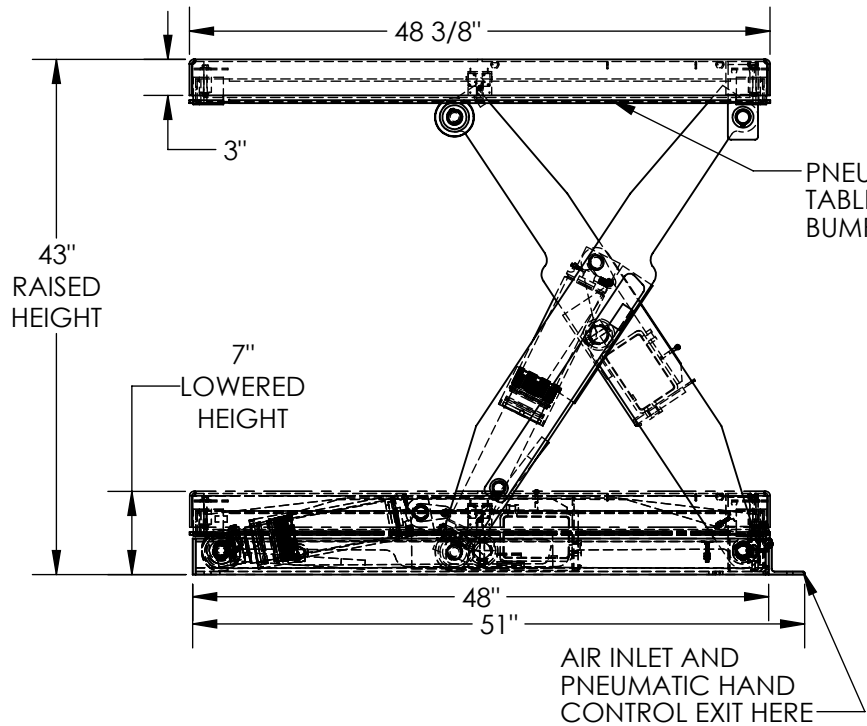

- ROTARY AIR / OIL POWER UNITS HAVE AN APPROX 1/2 GPM AT A MAXIMUM 3000 PSI
- AIR REQUIREMENTS 80 CFM @ 80 PSI WITH 3/4" DIAMETER AIR SUPPLY HOSE AT 50 FEET MAX
 - NOISE LEVEL APPROX. 100 dB @ 6 FEET
 - NOISE LEVEL APPROX. 90 dB @ 10 FEET
- * ALL ROTARY AIR / OIL POWER UNITS REQUIRE A FILTER / REGULATOR / LUBRICATOR (FRL)
 * FRLs ARE SOLD SEPARATELY
 * WARRANTY WILL BE VOIDED IF FRL IS NOT USED
 * HAND CONTROLS ON 8FT LONG HOSE

DIMENSION TOLERANCE ± 1/4"

STANDARD FEATURES

- MODEL NUMBER IS AHLT-4848-3-43
- PLATFORM WIDTH IS 48 3/8"
- PLATFORM LENGTH IS 48 3/8"
- OVERALL LENGTH IS 51"
- PLATFORM RAISED HEIGHT IS 43"
- PLATFORM LOWERED HEIGHT IS 7"
- TABLE CAPACITY (EVENLY DISTRIBUTED) LOAD IS 3,000 LBS
- CONTROL IS HANDHELD, 2 BUTTON PENDANT WITH MAXIMUM 8' PNEUMATIC CONTROL
- SAFETY MAINTENANCE PROPS, DISPLACEMENT STYLE CYLINDERS INSTALLED ROD DOWN EMERGENCY SAFETY STOP HYDRAULIC FUSES IN ALL CYLINDER UNITS
- INTERNAL POWER UNIT
- DURABLE LIQUID PAINT BLUE FINISH

SPECIAL FEATURES

NONE

PLEASE CIRCLE SPECIFICATIONS:

POWER	AC	DC (12V)	AIR/OIL
MOTOR VOLTAGE	115	208	230 460
DEDICATED CIRCUIT REQUIRED 60Hz			
MOTOR PHASE	SINGLE	THREE	
CONTROL	HAND	FOOT	

- DECK TOLERANCE ± 1/2"
- TABLE HEIGHT TOLERANCE ± 1/2"
- DECK FLATNESS ± 1/4"

APPROVAL

I, THE UNDERSIGNED, AGREE THAT THE PRODUCT AS REPRESENTED SATISFIES DESIGN AND DIMENSION REQUIREMENTS. I ALSO ACKNOWLEDGE MY DUTY TO CONFIRM PRODUCT AND INSTALLATION COMPLIANCE WITH ALL APPLICABLE FEDERAL, STATE AND LOCAL REGULATIONS AND STANDARDS.

UNITS REQUIRING APPROVAL DRAWINGS OR MODIFIED ARE NON-RETURNABLE

[] As drawn [] As marked

Signed: _____ Date: _____

Printed Name: _____

LEAD TIME WILL START UPON RECEIPT OF SIGNED APPROVAL DRAWING

DISTRIBUTOR'S NAME:		P.O.#
VESTIL MANUFACTURING		X
DRAWN BY: CRA		W.O.#
DATE: 03/08/2019		X
REFERENCE: X	SCALE: 1:16	SALES: X
QUOTED LEAD TIME: X	QUOTE # X	FILE NAME:
		24-007-051-103