

# ADJUSTABLE WORK-MATE STAND, ALUMINUM - AHT-H-2424-A

APPROX WEIGHT: 40.30 lbs.  
 DOES NOT INCLUDE WEIGHT OF POWER OR PACKAGING!!!

\*\*\* ANY ADDITIONS, DELETIONS, OR OMISSIONS MUST BE CORRECTED ON THIS DRAWING AS THIS DRAWING WILL BE CONSIDERED ALL INCLUSIVE \*\*\*  
 ALL GRAPHICS PROVIDED ARE FOR REFERENCE ONLY. IF CERTAIN DIMENSIONS ARE CRITICAL PLEASE VERIFY THOSE DIMENSIONS WITH YOUR SALESPERSON

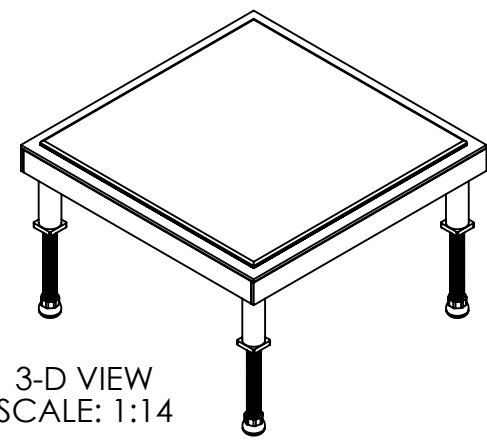
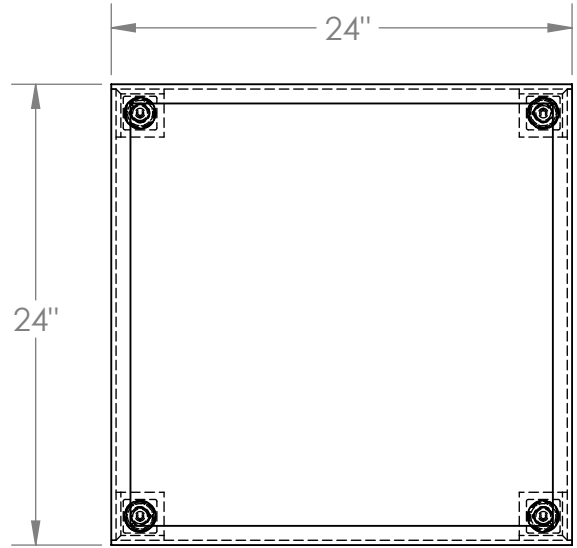

3-D VIEW  
 SCALE: 1:14

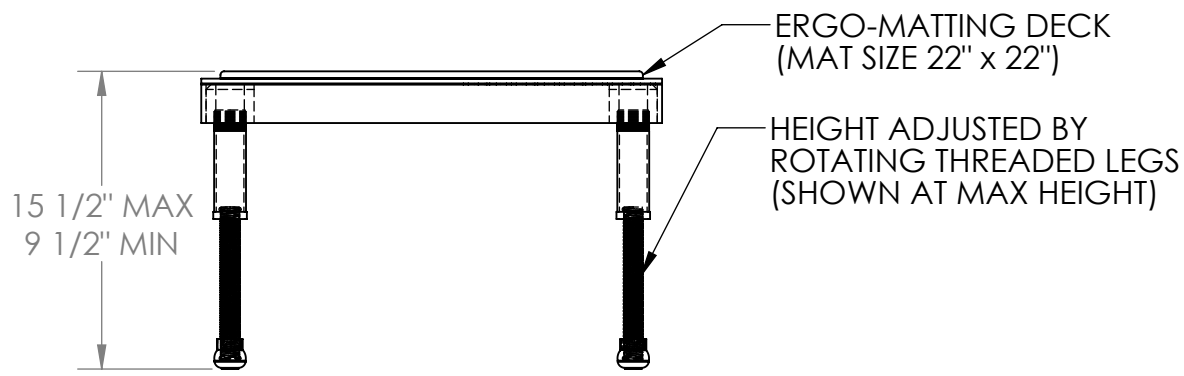

DIMENSION TOLERANCE  $\pm 1/4$ "

## STANDARD FEATURES

## SPECIAL FEATURES

- MODEL NUMBER : AHT-H-2424-A
- CAPACITY: 500 LBS.
- DECK WIDTH: 24"
- DECK LENGTH: 24"
- RAISED HEIGHT: 15 1/2"
- LOWERED HEIGHT: 9 1/2"
- ALUMINUM PLATFORM WITH POWDER COATED STEEL LEGS
- ERGO MATTING IS BLUE

NONE

APPROVAL

I, THE UNDERSIGNED, AGREE THAT THE PRODUCT AS REPRESENTED SATISFIES DESIGN AND DIMENSION REQUIREMENTS. I ALSO ACKNOWLEDGE MY DUTY TO CONFIRM PRODUCT AND INSTALLATION COMPLIANCE WITH ALL APPLICABLE FEDERAL, STATE AND LOCAL REGULATIONS AND STANDARDS.

**ANY MODIFIED UNITS ARE NON-RETURNABLE**

As drawn       As marked

Signed: \_\_\_\_\_ Date: \_\_\_\_\_

Printed Name: \_\_\_\_\_

LEAD TIME WILL START UPON RECEIPT OF SIGNED APPROVAL DRAWING

FOR INTERNAL USE ONLY PROJECT SIGN OFF	
SALES	
ENG.	
FAB.	
POWER	

DISTRIBUTOR'S NAME:		P.O.#
VESTIL MANUFACTURING		X
W.O.#		X
DRAWN BY: MTS	DATE: 10/10/14	SALES: X
REFERENCE: X	SCALE: 1:10	FILE NAME:
QUOTED LEAD TIME: X	QUOTE # X	14-007-279