

# ADJ WORK-MATE STAND - MODEL: AHT-L-1948

APPROX WEIGHT: 52.54 lbs.  
 DOES NOT INCLUDE WEIGHT OF POWER OR PACKAGING!!!

\*\*\* ANY ADDITIONS, DELETIONS, OR OMISSIONS MUST BE CORRECTED ON THIS DRAWING AS THIS DRAWING WILL BE CONSIDERED ALL INCLUSIVE \*\*\*  
 ALL GRAPHICS PROVIDED ARE FOR REFERENCE ONLY. IF CERTAIN DIMENSIONS ARE CRITICAL PLEASE VERIFY THOSE DIMENSIONS WITH YOUR SALESPERSON

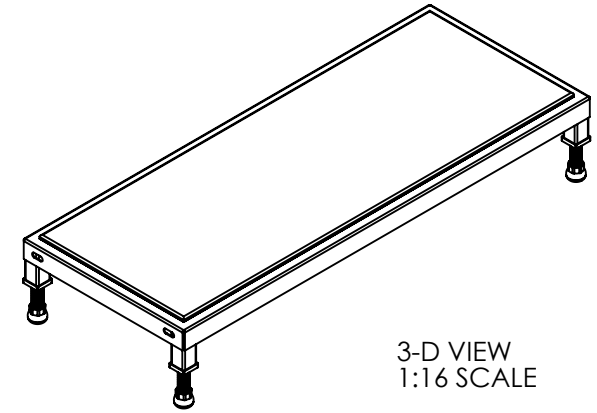
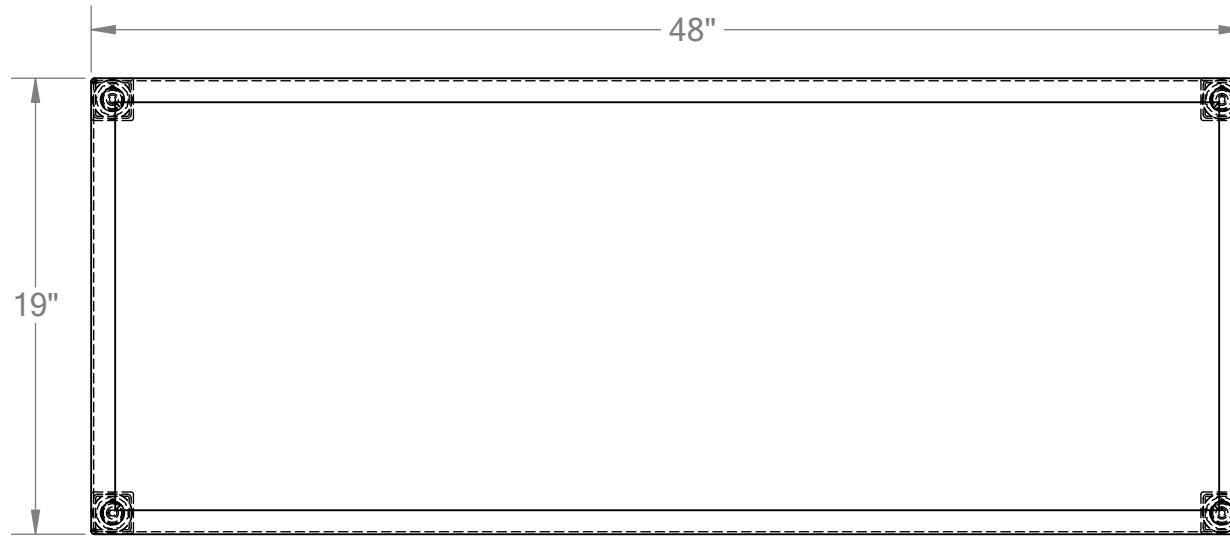

3-D VIEW  
 1:16 SCALE

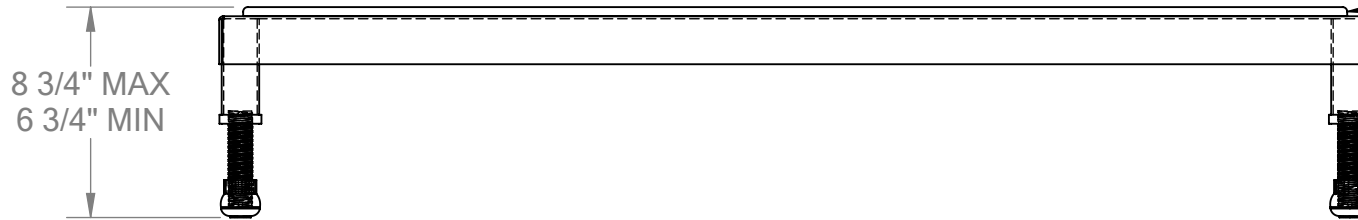

ERGO-MATTING DECK  
 (MAT SIZE 17" x 46")

HEIGHT ADJUSTED BY  
 ROTATING THREADED LEGS  
 (SHOWN AT MAX HEIGHT)

DIMENSION TOLERANCE  $\pm 1/4"$

## STANDARD FEATURES

## SPECIAL FEATURES

MODEL NUMBER : AHT-L-1948  
 CAPACITY: 500 LBS.  
 DECK WIDTH: 19"  
 DECK LENGTH: 48"  
 RAISED HEIGHT: 8 3/4"  
 LOWERED HEIGHT: 6 3/4"  
 ALL STEEL CONSTRUCTION  
 (ASTM A-36 MIN.)  
 WITH WELDING TO MEET AWS.  
 ERGO MATTING IS BLUE  
 TOUGH BAKED IN POWDER  
 COATED YELLOW FINISH

NONE

**APPROVAL**

I, THE UNDERSIGNED, AGREE THAT THE PRODUCT AS REPRESENTED SATISFIES DESIGN AND DIMENSION REQUIREMENTS. I ALSO ACKNOWLEDGE MY DUTY TO CONFIRM PRODUCT AND INSTALLATION COMPLIANCE WITH ALL APPLICABLE FEDERAL, STATE AND LOCAL REGULATIONS AND STANDARDS.  
**ANY MODIFIED UNITS ARE NON-RETURNABLE**  
 As drawn       As marked

Signed: \_\_\_\_\_ Date: \_\_\_\_\_  
 Printed Name: \_\_\_\_\_  
**LEAD TIME WILL START UPON RECEIPT OF SIGNED APPROVAL DRAWING**

FOR INTERNAL USE ONLY PROJECT SIGN OFF	
SALES	
ENG.	
FAB.	
POWER	

DISTRIBUTOR'S NAME: <b>VESTIL MANUFACTURING</b>		P.O.# X
DRAWN BY: MTS		W.O.# X
DATE: 12/27/13	SALES: X	FILE NAME: 14-007-198
REFERENCE: X	SCALE: 1:8	
QUOTED LEAD TIME: X	QUOTE # X	