

ADJUSTABLE WORK-MATE STAND, ALUMINUM - AHW-L-2448-A

*** ANY ADDITIONS, DELETIONS, OR OMISSIONS MUST BE CORRECTED ON THIS DRAWING AS THIS DRAWING WILL BE CONSIDERED ALL INCLUSIVE ***

ALL GRAPHICS PROVIDED ARE FOR REFERENCE ONLY. IF CERTAIN DIMENSIONS ARE CRITICAL PLEASE VERIFY THOSE DIMENSIONS WITH YOUR SALESPERSON

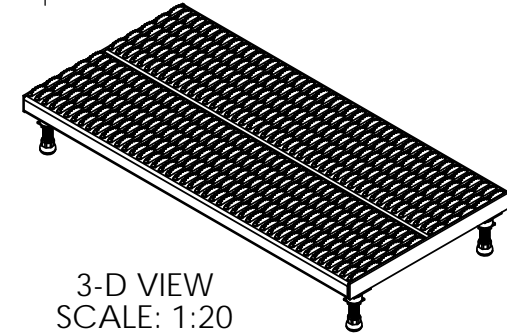
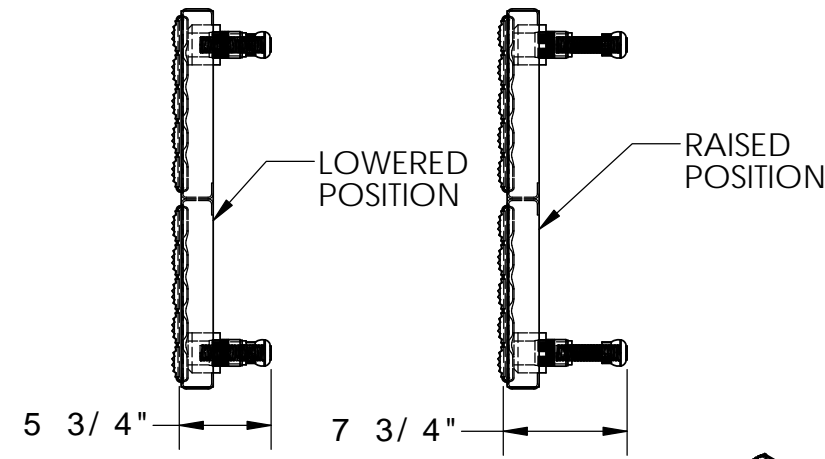
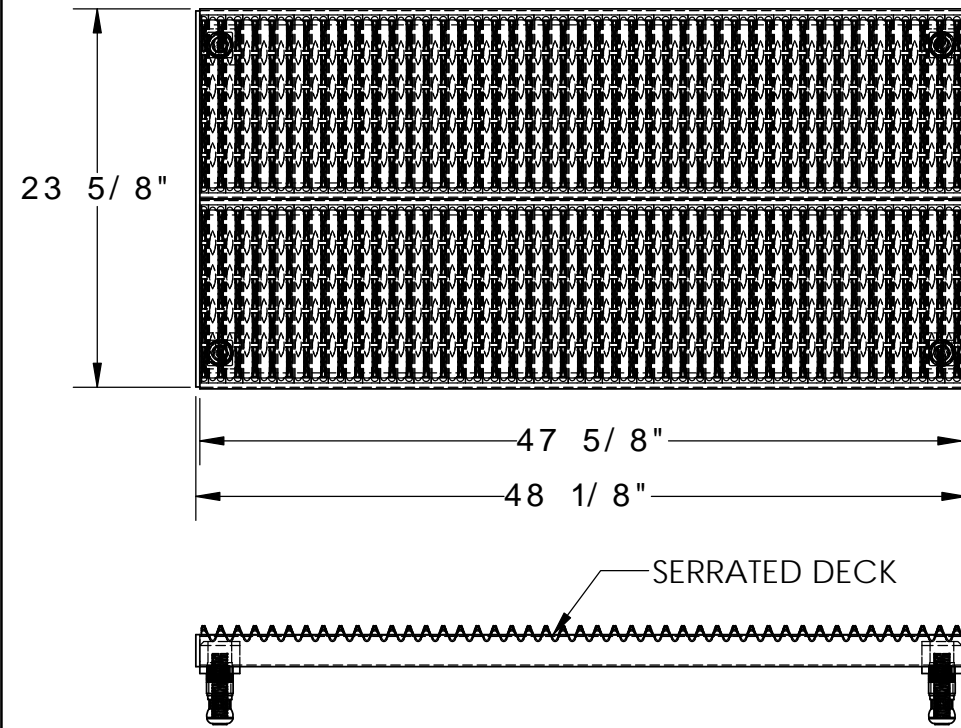

STANDARD FEATURES

- MODEL NUMBER: AHW-L-2448-A
- CAPACITY: 500 LBS. EVENLY DISTRIBUTED
- PLATFORM SURFACE: SERRATED
- PLATFORM SIZE: 23 5/8" W x 48 1/8" L
- PLATFORM SERVICE RANGE: 5 3/4" - 7 3/4"
- ALUMINUM PLATFORM WITH POWDERCOATED
- STEEL LEGS AND RUBBER CRUTCH TIPS ON LEGS

SPECIAL FEATURES

NONE

APPROX WEIGHT: 40.09 lbs.
DOES NOT INCLUDE WEIGHT OF POWER OR PACKAGING!!!

A P P R O V A L	I, THE UNDERSIGNED, AGREE THAT THE PRODUCT AS REPRESENTED SATISFIES DESIGN AND DIMENSION REQUIREMENTS. I ALSO ACKNOWLEDGE MY DUTY TO CONFIRM PRODUCT AND INSTALLATION COMPLIANCE WITH ALL APPLICABLE FEDERAL, STATE AND LOCAL REGULATIONS AND STANDARDS.	
	ALL SPECIAL UNITS ARE NON-RETURNABLE	
	[] As drawn [] As marked	
Signed: _____		Date: _____
LEAD TIME WILL START UPON RECEIPT OF SIGNED APPROVAL DRAWING		

DISTRIBUTOR'S NAME:		P.O.#
VESTIL MANUFACTURING		X
DRAWN BY: BJW		W.O.#
DATE: 5/21/2012		X
REFERENCE: X		SALES: X
SCALE: 1:12		FILE NAME:
QUOTED LEAD TIME: X		14-007-149
QUOTE #		
X		