

GAS POWERED ALL TERRAIN PALLET TRUCK - ALL-T-1-GPT-ST-L

ANY ADDITIONS, DELETIONS, OR OMISSIONS MUST BE CORRECTED ON THIS DRAWING AS THIS DRAWING WILL BE CONSIDERED ALL INCLUSIVE

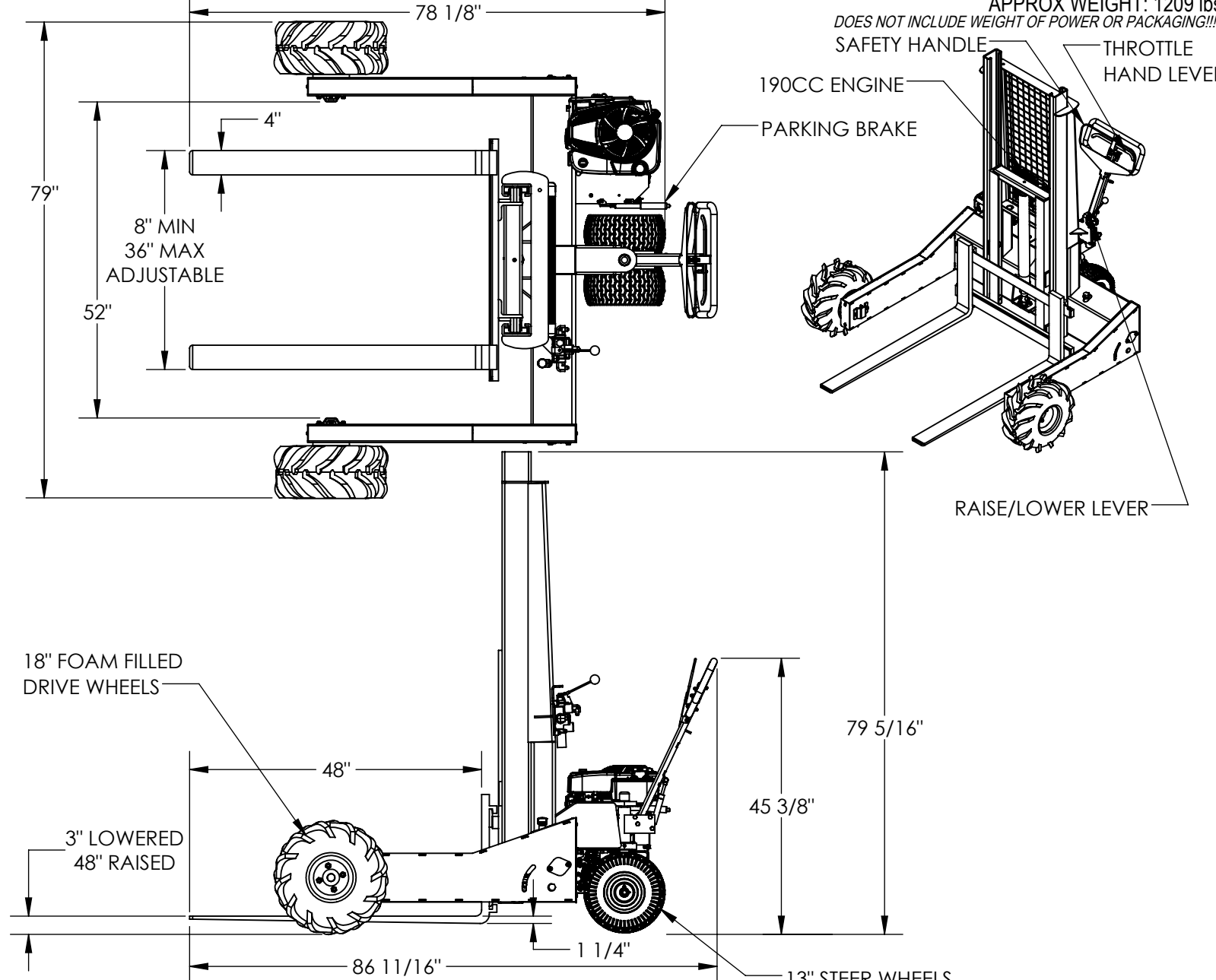

ALL GRAPHICS PROVIDED ARE FOR REFERENCE ONLY. IF CERTAIN DIMENSIONS ARE CRITICAL PLEASE VERIFY THOSE DIMENSIONS WITH YOUR SALESPERSON
DIMENSION TOLERANCE ± 1"

STANDARD FEATURES

- MODEL NUMBER IS ALL-T-1-GPT-ST-L
- CAPACITY IS 1,000 LBS
- OVERALL WIDTH IS 79"
- STRADDLE WIDTH IS 52"
- SERVICE HEIGHT IS 3" TO 48"
- FORKS ARE ADJUSTABLE FROM 8" TO 36"
- FORKS ARE 1 1/4" THICK X 4" WIDE X 48" LONG
- OVERALL LENGTH IS 86 11/16"
- OVERALL HEIGHT IS 79 5/16"
- 18" FOAM FILLED FRONT WHEELS
- SAFETY HANDLE WITH FORWARD/NEUTRAL/REVERSE
- 190CC BRIGGS AND STRATTON ENGINE
- HAND LEVER TO CONTROL LIFT/LOWER
- DURABLE LIQUID PAINT BLUE FINISH

SPECIAL FEATURES

NONE

A P P R O V A L	I, THE UNDERSIGNED, AGREE THAT THE PRODUCT AS REPRESENTED SATISFIES DESIGN AND DIMENSION REQUIREMENTS. I ALSO ACKNOWLEDGE MY DUTY TO CONFIRM PRODUCT AND INSTALLATION COMPLIANCE WITH ALL APPLICABLE FEDERAL, STATE AND LOCAL REGULATIONS AND STANDARDS.	
	UNITS REQUIRING APPROVAL DRAWINGS OR MODIFIED ARE NON-RETURNABLE	
	[] As drawn [] As marked	
	Signed: _____ Date: _____	
Printed Name: _____		
<i>LEAD TIME WILL START UPON RECEIPT OF SIGNED APPROVAL DRAWING</i>		

DISTRIBUTOR'S NAME:		P.O.#
VESTIL MANUFACTURING		X
DRAWN BY: KGH		W.O.#
DATE: 3/8/2018		X
REFERENCE: X		SALES: X
SCALE: 1:24		FILE NAME:
QUOTED LEAD TIME: X		50-007-030
QUOTE #		X