

GAS POWERED ALL TERRAIN PALLET TRUCK - ALL-T-4-GPT

ANY ADDITIONS, DELETIONS, OR OMISSIONS MUST BE CORRECTED ON THIS DRAWING AS THIS DRAWING WILL BE CONSIDERED ALL INCLUSIVE
 APPROX WEIGHT: 1040 lbs.
 DOES NOT INCLUDE WEIGHT OF POWER OR PACKAGING!!!

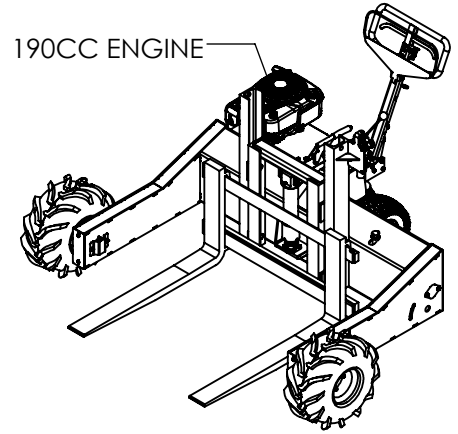
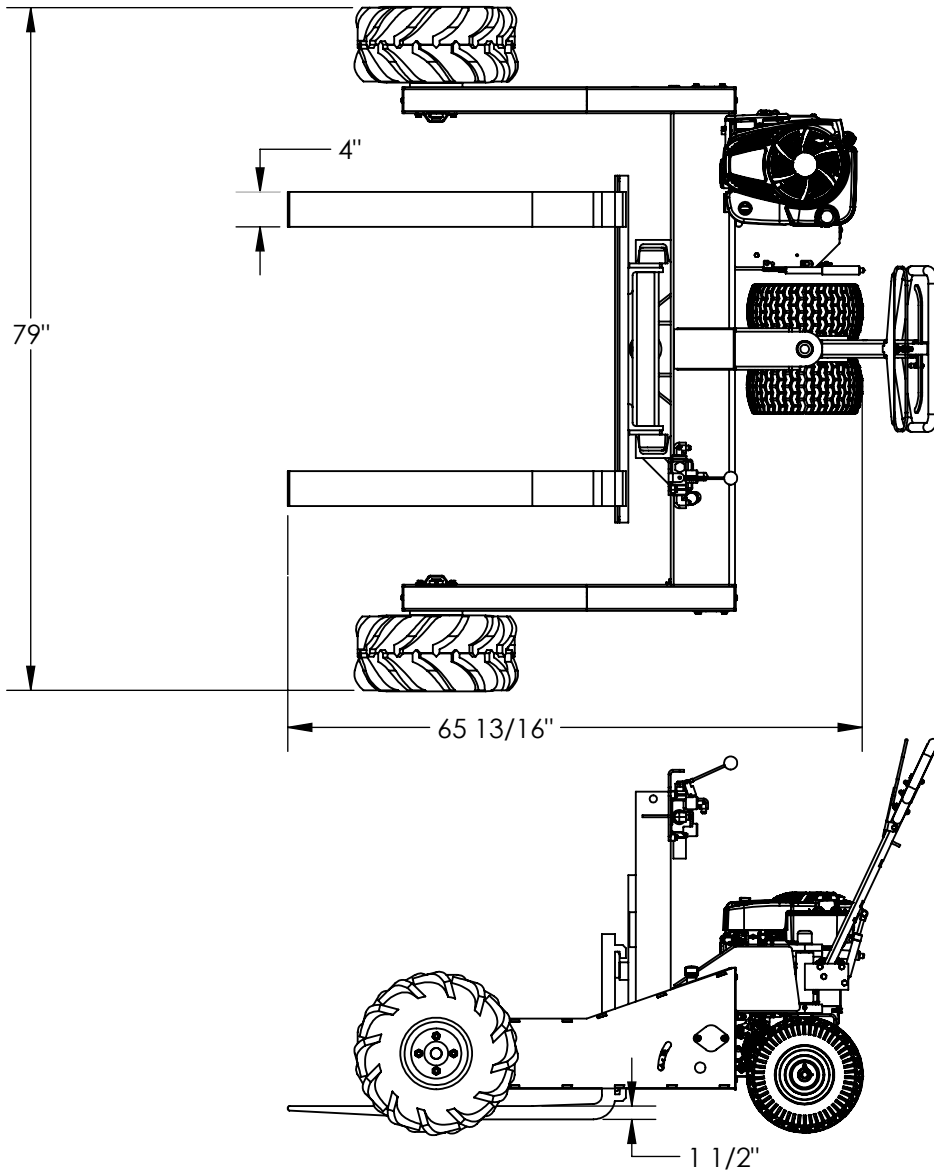

ALL GRAPHICS PROVIDED ARE FOR REFERENCE ONLY. IF CERTAIN DIMENSIONS ARE CRITICAL PLEASE VERIFY THOSE DIMENSIONS WITH YOUR SALESPERSON
 DIMENSION TOLERANCE $\pm 1"$

STANDARD FEATURES

- MODEL NUMBER IS ALL-T-4-GPT
- CAPACITY IS 4,000 LBS
- OVERALL WIDTH IS 79"
- STRADDLE WIDTH IS 52"
- SERVICE RANGE IS 3" TO 12"
- FORKS ARE ADJUSTABLE FROM 8" TO 36"
- FORKS ARE 1 1/2" THICK X 4" WIDE X 36" LONG
- OVERALL LENGTH IS 74 7/16"
- OVERALL HEIGHT IS 45 1/16"
- 18" FOAM FILLED FRONT WHEELS
- SAFETY HANDLE WITH

- FORWARD/NEUTRAL/REVERSE
- 190CC BRIGGS AND STRATTON ENGINE
- HAND LEVER TO CONTROL LIFT/LOWER
- DURABLE LIQUID PAINT BLUE FINISH

SPECIAL FEATURES

NONE

APPROVAL

I, THE UNDERSIGNED, AGREE THAT THE PRODUCT AS REPRESENTED SATISFIES DESIGN AND DIMENSION REQUIREMENTS. I ALSO ACKNOWLEDGE MY DUTY TO CONFIRM PRODUCT AND INSTALLATION COMPLIANCE WITH ALL APPLICABLE FEDERAL, STATE AND LOCAL REGULATIONS AND STANDARDS.
UNITS REQUIRING APPROVAL DRAWINGS OR MODIFIED ARE NON-RETURNABLE
 As drawn As marked

Signed: _____ Date: _____

Printed Name: _____

LEAD TIME WILL START UPON RECEIPT OF SIGNED APPROVAL DRAWING

DISTRIBUTOR'S NAME:		P.O.#
VESTIL MANUFACTURING		X
DRAWN BY: KGH		W.O.#
DATE: 3/8/2018		X
REFERENCE: X	SCALE: 1:22	SALES: X
QUOTED LEAD TIME: X	QUOTE #	FILE NAME:
	X	50-007-015