

ADJ. HEIGHT STEP STAND W/HANDRAIL - ASP-48-3-HR

APPROX WEIGHT: 148.11 lbs.
DOES NOT INCLUDE WEIGHT OF POWER OR PACKAGING!!!

*** ANY ADDITIONS, DELETIONS, OR OMISSIONS MUST BE CORRECTED ON THIS DRAWING AS THIS DRAWING WILL BE CONSIDERED ALL INCLUSIVE ***

ALL GRAPHICS PROVIDED ARE FOR REFERENCE ONLY. IF CERTAIN DIMENSIONS ARE CRITICAL PLEASE VERIFY THOSE DIMENSIONS WITH YOUR SALESPERSON

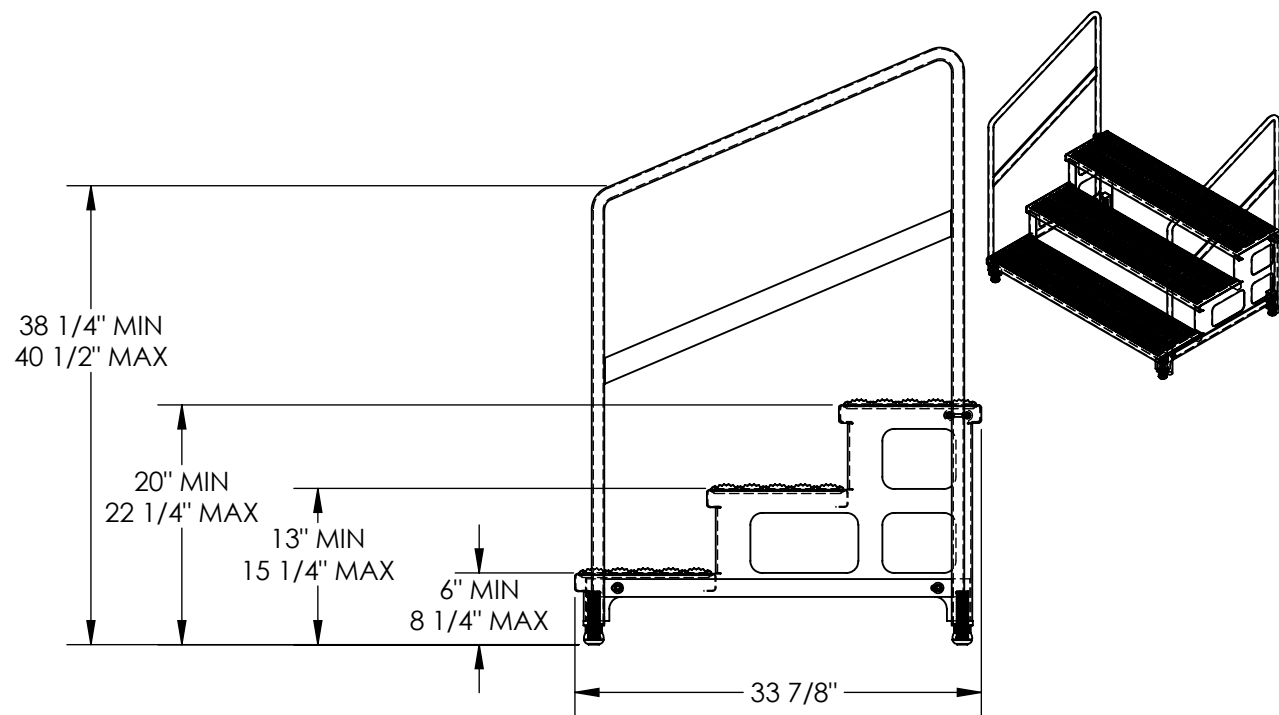
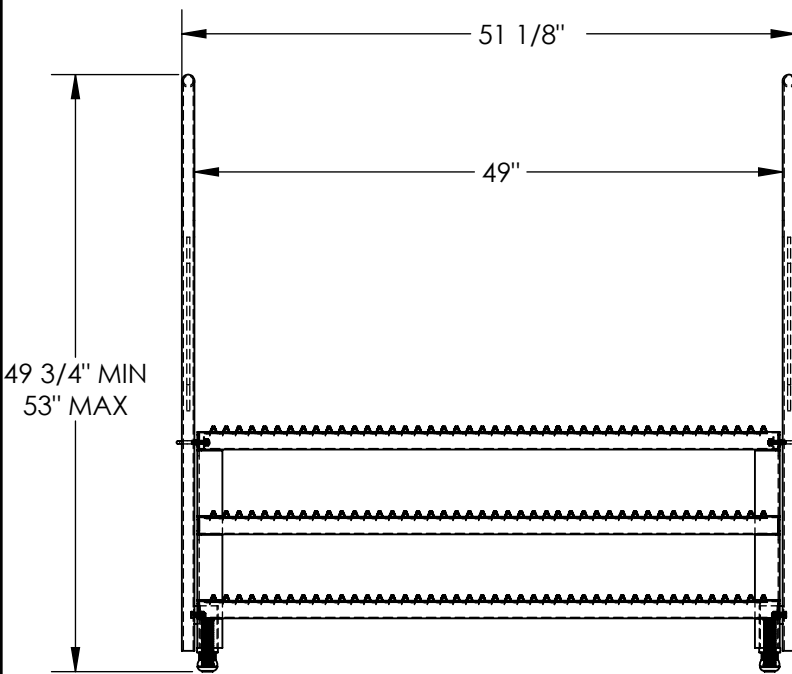

STANDARD FEATURES

- MODEL NUMBER IS ASP-48-3-HR
- CAPACITY: 500 LBS
- OVERALL WIDTH IS: 51 1/8"
- USABLE WIDTH: 49"
- OVERALL LENGTH: 33 7/8"
- OVERALL HEIGHT: 53"
- BOTTOM STEP HEIGHT: MIN. 6", MAX. 8 1/4"
- MIDDLE STEP HEIGHT: MIN. 13", MAX. 15 1/4"
- TOP STEP HEIGHT: MIN. 20", MAX. 22 1/4"
- STEPS: SERRATED STEEL 1 1/4" DEEP
- LEGS:
 - ADJUSTABLE
 - ANTI-SLIP TIPS
- TOUGH BAKED IN POWDER COATED YELLOW FINISH
- BOLT ON HANDRAILS

SPECIAL FEATURES

NONE

DIMENSION TOLERANCE $\pm 1/4"$

APPROVAL

I, THE UNDERSIGNED, AGREE THAT THE PRODUCT AS REPRESENTED SATISFIES DESIGN AND DIMENSION REQUIREMENTS. I ALSO ACKNOWLEDGE MY DUTY TO CONFIRM PRODUCT AND INSTALLATION COMPLIANCE WITH ALL APPLICABLE FEDERAL, STATE AND LOCAL REGULATIONS AND STANDARDS.
UNITS REQUIRING APPROVAL DRAWINGS OR MODIFIED ARE NON-RETURNABLE
 As drawn As marked

Signed: _____ Date: _____

Printed Name: _____

LEAD TIME WILL START UPON RECEIPT OF SIGNED APPROVAL DRAWING

DISTRIBUTOR'S NAME:		P.O.#
VESTIL MANUFACTURING		X
DRAWN BY: NBE		W.O.#
DATE: 10/24/2023		X
REFERENCE: X	SCALE: 1:16	SALES: X
QUOTED LEAD TIME: X	QUOTE #	FILE NAME:
	X	14-007-353