

This document contains the proprietary information of Tandemloc, Inc. and your access and use shall be, and is at all times, pursuant to and limited by the Tandemloc, Inc. Terms of Use. You shall not, and shall not encourage, assist, or authorize another party to copy, distribute, publicly display, modify, reverse engineer, decompile, or take any other action to reproduce this document or the information contained herein.

©2019 by Tandemloc, Inc.
Dimensions are subject to manufacturing tolerance and change.

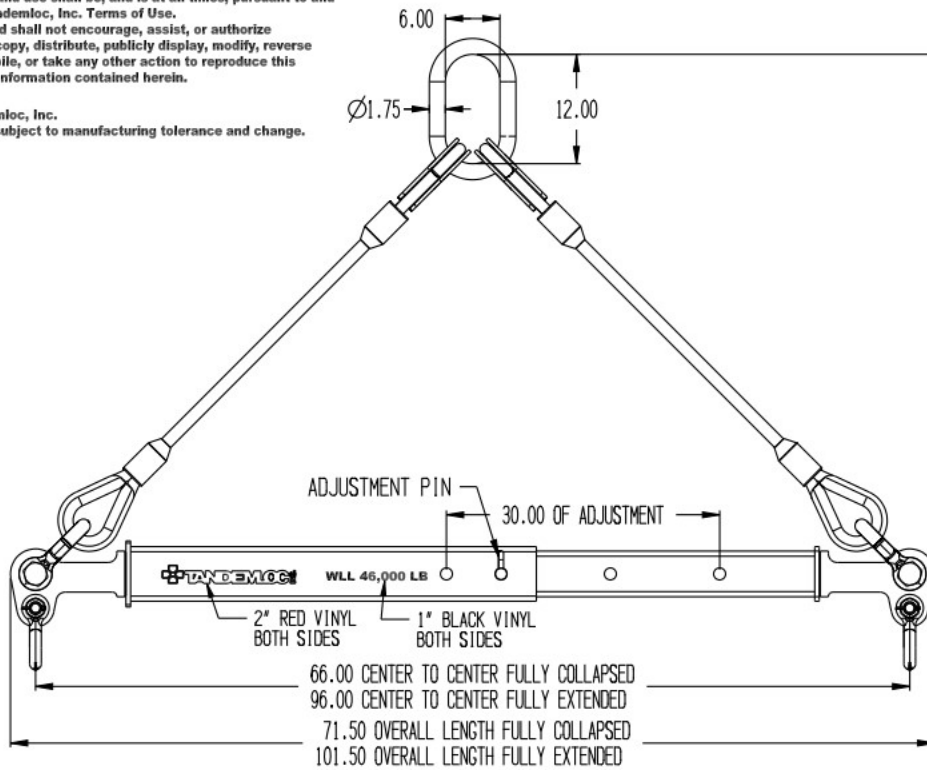

| REVISIONS | | | |
|-----------|-------------|------|----------|
| NO. | DESCRIPTION | DATE | APPROVED |

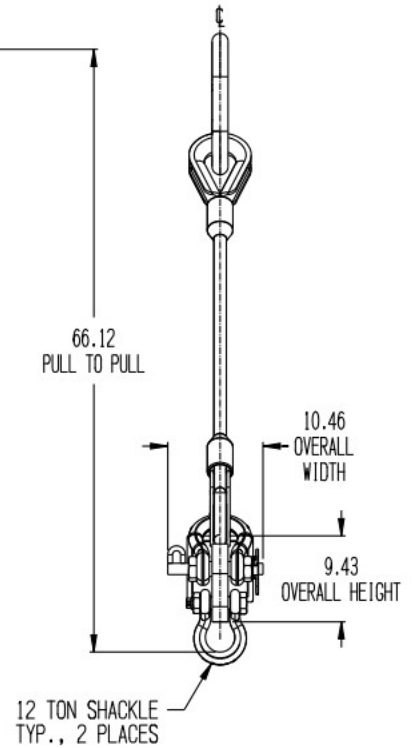

- NOTES:
- PART NO.: AT14A046-096-PA, 66"-96" TELESCOPIC SPREADER
 AT14A046-096SPA, 66"-96" TELESCOPIC SPREADER WITH TOP SLING
 - WLL: 46,000 LB. @ 45° MINIMUM
 - PROOF TESTED TO 125% (57,500 LB.) AND CERTIFIED
 - STANDARD SPECIFICATION # EAD21000A APPLIES
 - FINISH: SANDBLAST AND PRIME AND PAINT YELLOW
 - CALCULATED WEIGHT: 320 LB. SPREADER WITH SLING: 431 LB.
 - DESIGNED AND MANUFACTURED TO MEET OR EXCEED ASME B30.20 AND BTH-1, DESIGN CATEGORY B, SERVICE CLASS 0.

** DO NOT SIGN IF CHANGES ARE REQUIRED **

CUSTOMER APPROVAL: _____
 DATE: _____

| | | |
|---|--|--|
| <small>1 1/2" DIMENSIONS APPLICABLE UNLESS OTHERWISE NOTED. DIMENSIONS ARE IN INCHES & TOLERANCES ARE: .XX ±.01 .XXX ±.01 .XXX ±.01</small> | <small>1" DIMENSIONS APPLICABLE UNLESS OTHERWISE NOTED. DIMENSIONS ARE IN INCHES & TOLERANCES ARE: 0 TO 4" ±.01 4.01" TO 7" ±.02 7.01" TO 30.0" ±.04 OVER 30.0" ±.06</small> | |
| <small>THIS DOCUMENT CONTAINS THE PROPRIETARY INFORMATION OF TANDEMLOC, INC. NO PART OF THIS DOCUMENT, WITHOUT THE WRITTEN PERMISSION OF TANDEMLOC, INC. SHALL BE REPRODUCED OR TRANSMITTED IN ANY FORM OR BY ANY MEANS, ELECTRONIC OR MECHANICAL, INCLUDING PHOTOCOPYING, RECORDING, OR BY ANY INFORMATION STORAGE AND RETRIEVAL SYSTEM.</small> | | TITEL AT14A046-096-PA 66"-96" TELESCOPIC SPREADER |
| <small>APPROVALS</small> DESIGNER: [Signature] DATE: 02-07-19 | <small>DATE CODE</small> D 65059 | <small>REV. NO.</small> SAT14A046-096-PA-1 |