

This document contains the proprietary information of Tandemloc, Inc. and your access and use shall be, and is at all times, pursuant to and limited by the Tandemloc, Inc. Terms of Use. You shall not, and shall not encourage, assist, or authorize another party to copy, distribute, publicly display, modify, reverse engineer, decompile, or take any other action to reproduce this document or the information contained herein.

REVISIONS			
NO.	DESCRIPTION	DATE	APPROV.

©2019 by Tandemloc, Inc.

Dimensions are subject to manufacturing tolerance and change.

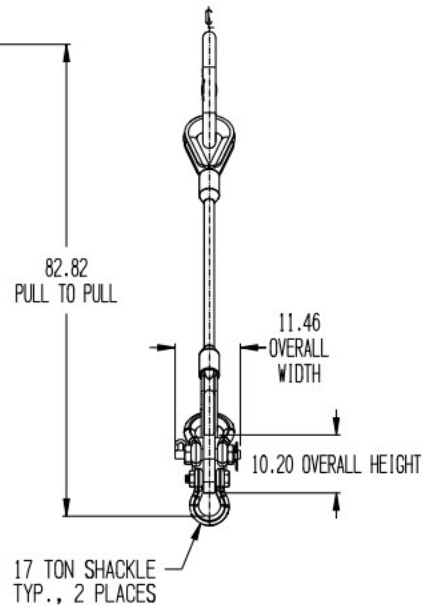
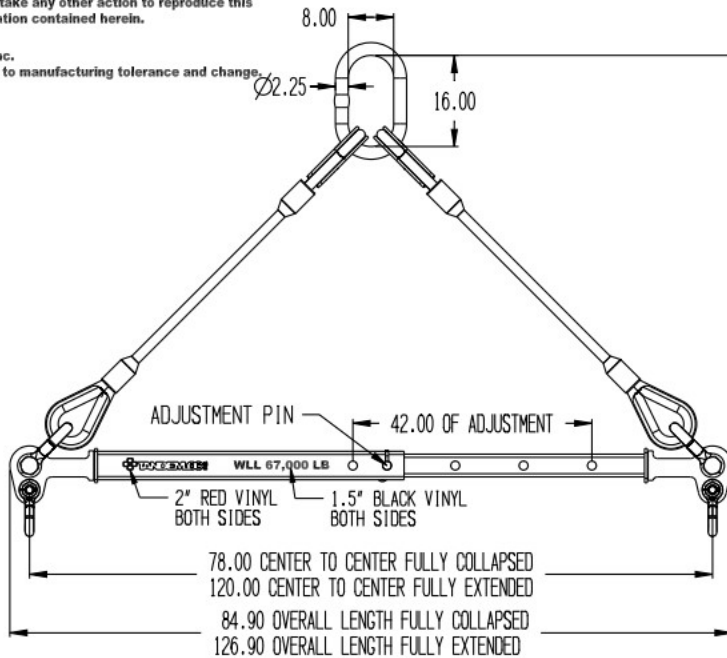

NOTES:

- PART NO.: AT14A067-120-PA, 78"-120" TELESCOPIC SPREADER
AT14A067-120SPA, 78"-120" TELESCOPIC SPREADER WITH TOP SLING
- WLL: 67,000 LB. @ 45° MINIMUM
- PROOF TESTED TO 125% (83,750 LB.) AND CERTIFIED
- STANDARD SPECIFICATION # EAD21000A APPLIES
- FINISH: SANDBLAST AND PRIME AND PAINT YELLOW
- CALCULATED WEIGHT: 390 LB. SPREADER WITH SLING: 738 LB.
- DESIGNED AND MANUFACTURED TO MEET OR EXCEED ASME B30.20 AND BTH-1, DESIGN CATEGORY B, SERVICE CLASS 0.

** DO NOT SIGN IF CHANGES ARE REQUIRED **

CUSTOMER APPROVAL: _____

DATE: _____

<small>1/16" DIMENSIONS APPLICABLE UNLESS OTHERWISE NOTED. DIMENSIONS ARE IN INCHES & TOLERANCES ARE: .XX ±.01, .XXX ±.005, .XXX ±.01 THIS DOCUMENT CONTAINS ONLY INFORMATION AS OF THE DATE PRINTED. TANDEMLOC, INC. SUBSIDIARY OF TANDEMLOC HOLDING CO. ALL RIGHTS RESERVED. TANDEMLOC, INC. IS A REGISTERED SERVICE MARK OF TANDEMLOC, INC. © COPYRIGHT © 2019 TANDEMLOC, INC.</small>	<small>1" DIMENSIONS APPLICABLE UNLESS OTHERWISE NOTED. DIMENSIONS ARE IN INCHES & TOLERANCES ARE: 0 TO 4" ±.01, 4.01" TO 7" ±.005, 7" TO 10" ±.005, OVER 10" ±.002</small>		TITLE	AT14A067-120-PA 78"-120" TELESCOPIC SPREADER	
			DATE	09-20-19	
DESIGNER	D	DATE	09-20-19	REV. NO.	1
CHECKED	D	DATE	09-20-19	PART NO.	SAT14A067-120-PA
APPROVED		DATE		SHEET	1 OF 1