

ADJUSTABLE TOTE DOLLIES - ATD-1622-6

APPROX WEIGHT: 36.61 lbs.
 DOES NOT INCLUDE WEIGHT OF POWER OR PACKAGING!!!

*** ANY ADDITIONS, DELETIONS, OR OMISSIONS MUST BE CORRECTED ON THIS DRAWING AS THIS DRAWING WILL BE CONSIDERED ALL INCLUSIVE ***

ALL GRAPHICS PROVIDED ARE FOR REFERENCE ONLY. IF CERTAIN DIMENSIONS ARE CRITICAL PLEASE VERIFY THOSE DIMENSIONS WITH YOUR SALESPERSON

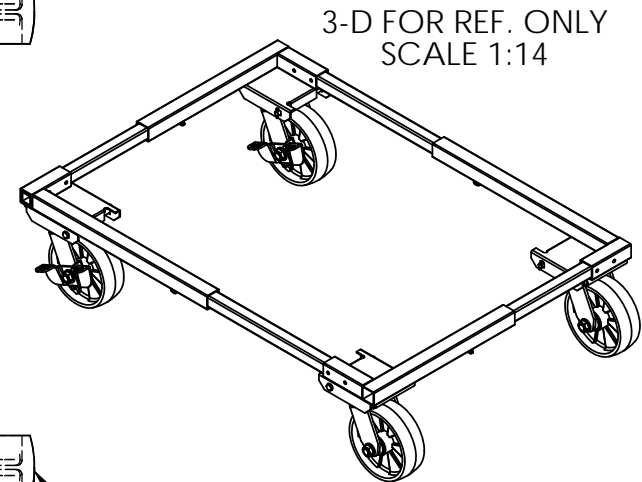
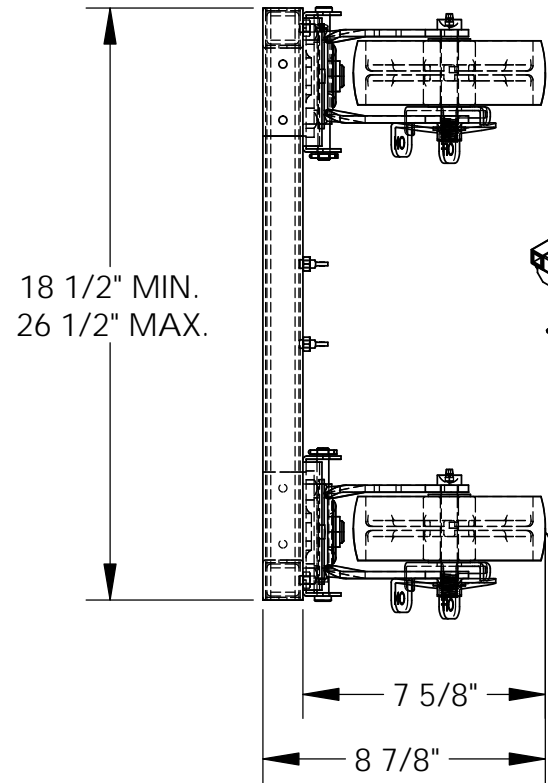
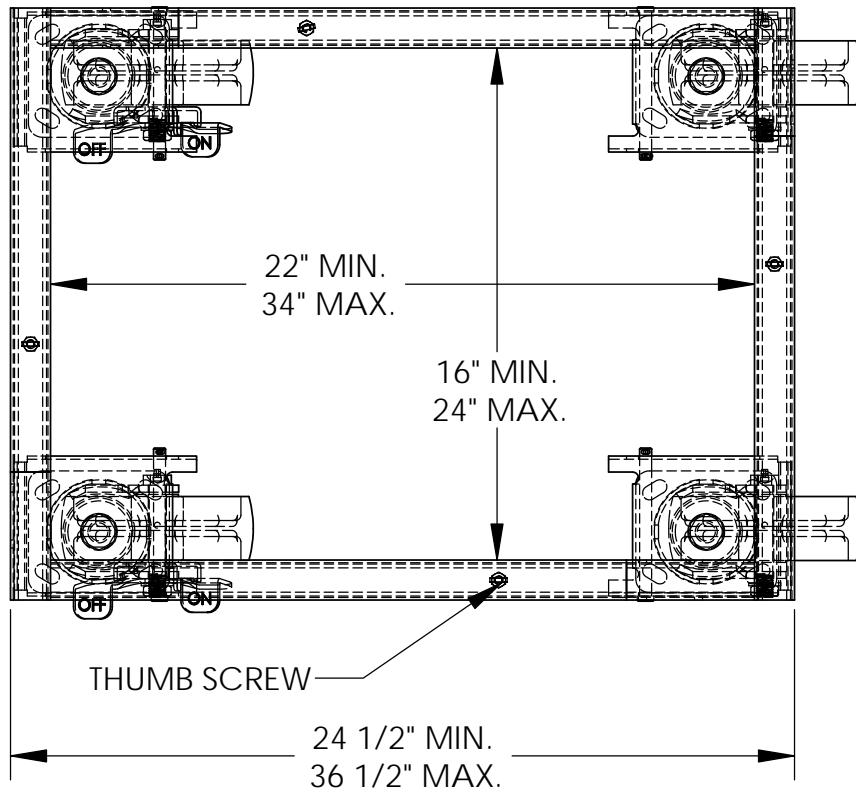

GLASS-FILLED-NYLON
SWIVEL CASTERS W/BRAKES

STANDARD FEATURES

- MODEL NUMBER IS ATD-1622-6
- CAPACITY IS 3,000 LBS.
- OVERALL WIDTH IS 18 1/2" TO 26 1/2"
- USABLE WIDTH IS 16" TO 24"
- OVERALL LENGTH IS 24 1/2" TO 36 1/2"
- USABLE LENGTH IS 22" TO 34"
- OVERALL HEIGHT IS 8 7/8"
- USABLE HEIGHT IS 7 5/8"
- CASTERS: 6 X 2 GLASS-FILLED-NYLON CASTER
 - 2- SWIVEL CASTERS
 - 2- SWIVEL CASTERS W/ BRAKE

SPECIAL FEATURES

NONE

APPROVAL	I, THE UNDERSIGNED, AGREE THAT THE PRODUCT AS REPRESENTED SATISFIES DESIGN AND DIMENSION REQUIREMENTS. I ALSO ACKNOWLEDGE MY DUTY TO CONFIRM PRODUCT AND INSTALLATION COMPLIANCE WITH ALL APPLICABLE FEDERAL, STATE AND LOCAL REGULATIONS AND STANDARDS.	
	ALL SPECIAL UNITS ARE NON-RETURNABLE [] As drawn [] As marked	
Signed: _____		Date: _____
LEAD TIME WILL START UPON RECEIPT OF SIGNED APPROVAL DRAWING		

DISTRIBUTOR'S NAME:		P.O.#
VESTIL MANUFACTURING		X
DRAWN BY: CA		W.O.#
DATE: 09/27/2011		X
REFERENCE: X	SCALE: 1:6	SALES: X
QUOTED LEAD TIME: X	QUOTE #	FILE NAME:
	X	32-007-034