

# BATTERY TRANSFER CART W/WINCH - BTC-CART-WINCH

APPROX WEIGHT: 343.10 lbs.  
DOES NOT INCLUDE WEIGHT OF POWER OR PACKAGING!!!

\*\*\*ANY ADDITIONS, DELETIONS, OR OMISSIONS MUST BE CORRECTED ON THIS DRAWING AS THIS DRAWING WILL BE CONSIDERED ALL INCLUSIVE\*\*\*

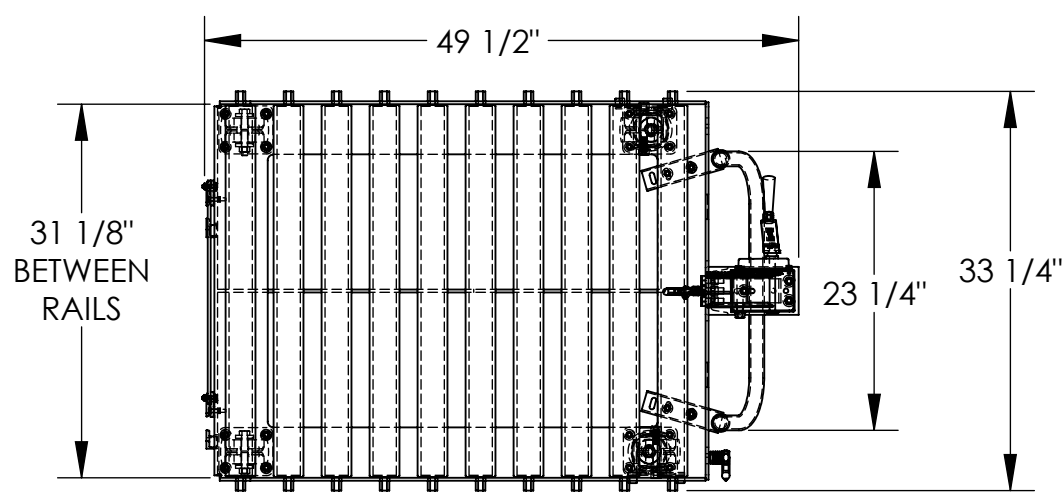

3-D VIEW FOR REFERENCE

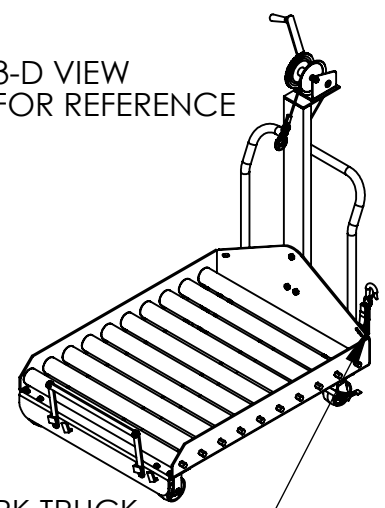

FORK TRUCK RESTRAINING STRAP CAN BE ATTACHED TO EITHER SIDE

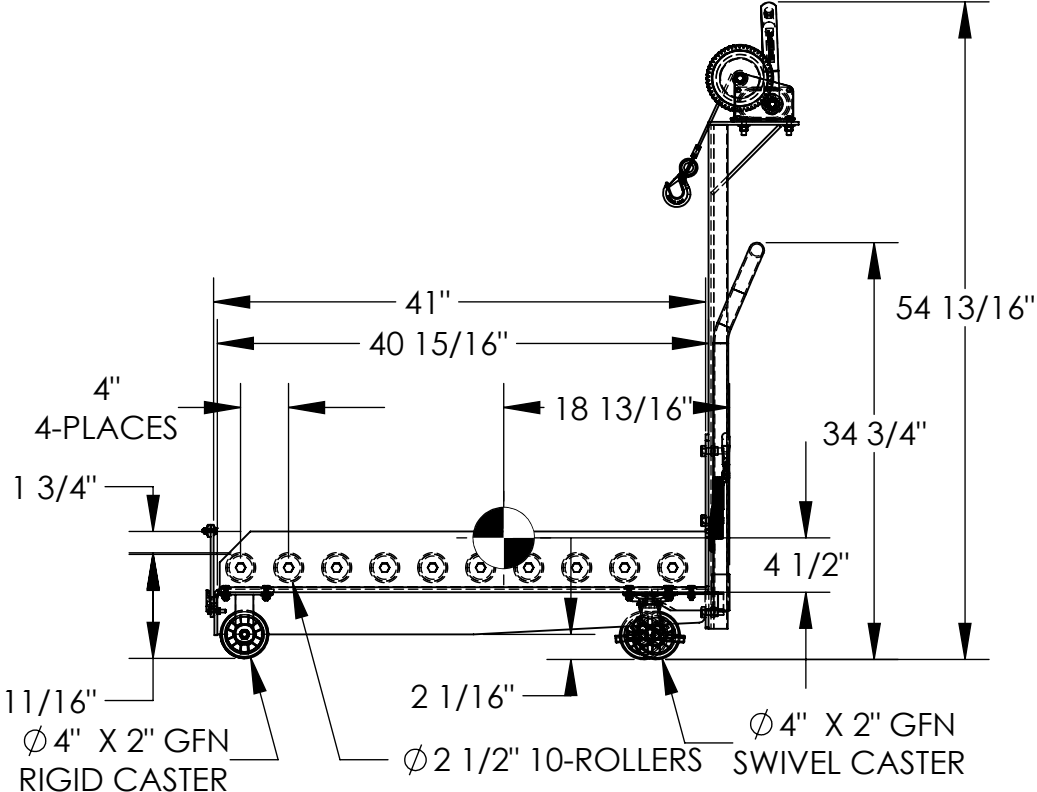

APPROX. WEIGHT / LOST LOAD = 343.10  
MINIMUM EFFECTIVE THICKNESS =  
FORK LENGTH - 40 15/16"  
VERTICAL CENTER OF GRAVITY = 4 1/2"  
HORIZONTAL CENTER OF GRAVITY = 18 13/16"

NEVER EXCEED LOAD CENTER RATING PER FORKTRUCK MANUFACTURERS GUIDELINES. DO NOT USE THIS FORK TRUCK ATTACHMENT IF LOAD WILL EXCEED FORK TRUCK MANUFACTURER'S LOAD CENTER RATING

ALL GRAPHICS PROVIDED ARE FOR REFERENCE ONLY. IF CERTAIN DIMENSIONS ARE CRITICAL PLEASE VERIFY THOSE DIMENSIONS WITH YOUR SALESPERSON

DIMENSION TOLERANCE ± 1/4"

## STANDARD FEATURES

- MODEL NUMBER IS BTC-CART-WINCH
- CAPACITY IS 4,000 LBS.
- USABLE WIDTH IS 31 1/8"
- USABLE LENGTH IS 41"
- FLOOR TO TOP OF ROLLERS IS 8 11/16" (+/-1/8")
- OVERALL WIDTH IS 33 1/4"
- OVERALL LENGTH IS 49 1/2"
- OVERALL HEIGHT IS 54 13/16"
- NUMBER OF ROLLERS IS 10
- (2)-Ø4" X 2" GFN RIGID CASTERS
- (2)-Ø4" X 2"GFN SWIVEL CASTERS
- TOUGH BAKED IN POWDER COAT YELLOW FINISH

## SPECIAL FEATURES

NONE

**A P P R O V A L**

I, THE UNDERSIGNED, AGREE THAT THE PRODUCT AS REPRESENTED SATISFIES DESIGN AND DIMENSION REQUIREMENTS. I ALSO ACKNOWLEDGE MY DUTY TO CONFIRM PRODUCT AND INSTALLATION COMPLIANCE WITH ALL APPLICABLE FEDERAL, STATE AND LOCAL REGULATIONS AND STANDARDS.

**UNITS REQUIRING APPROVAL DRAWINGS OR MODIFIED ARE NON-RETURNABLE**

[ ] As drawn [ ] As marked

Signed: \_\_\_\_\_ Date: \_\_\_\_\_

Printed Name: \_\_\_\_\_

LEAD TIME WILL START UPON RECEIPT OF SIGNED APPROVAL DRAWING

DISTRIBUTOR'S NAME: **VESTIL MANUFACTURING**

P.O.# X

W.O.# X

SALES: X

FILE NAME: 33-007-175-001

DRAWN BY: Q.WESTFALL DATE: 06/06/07

REFERENCE: X SCALE: 1:16

QUOTED LEAD TIME: X QUOTE # X