

MANUAL CAROUSEL WITH TOP PLATE - CA-18-2-TP-STP

ANY ADDITIONS, DELETIONS, OR OMISSIONS MUST BE CORRECTED ON THIS DRAWING AS THIS DRAWING WILL BE CONSIDERED ALL INCLUSIVE

APPROX WEIGHT: 43.19 lbs.
DOES NOT INCLUDE WEIGHT OF POWER OR PACKAGING!!!

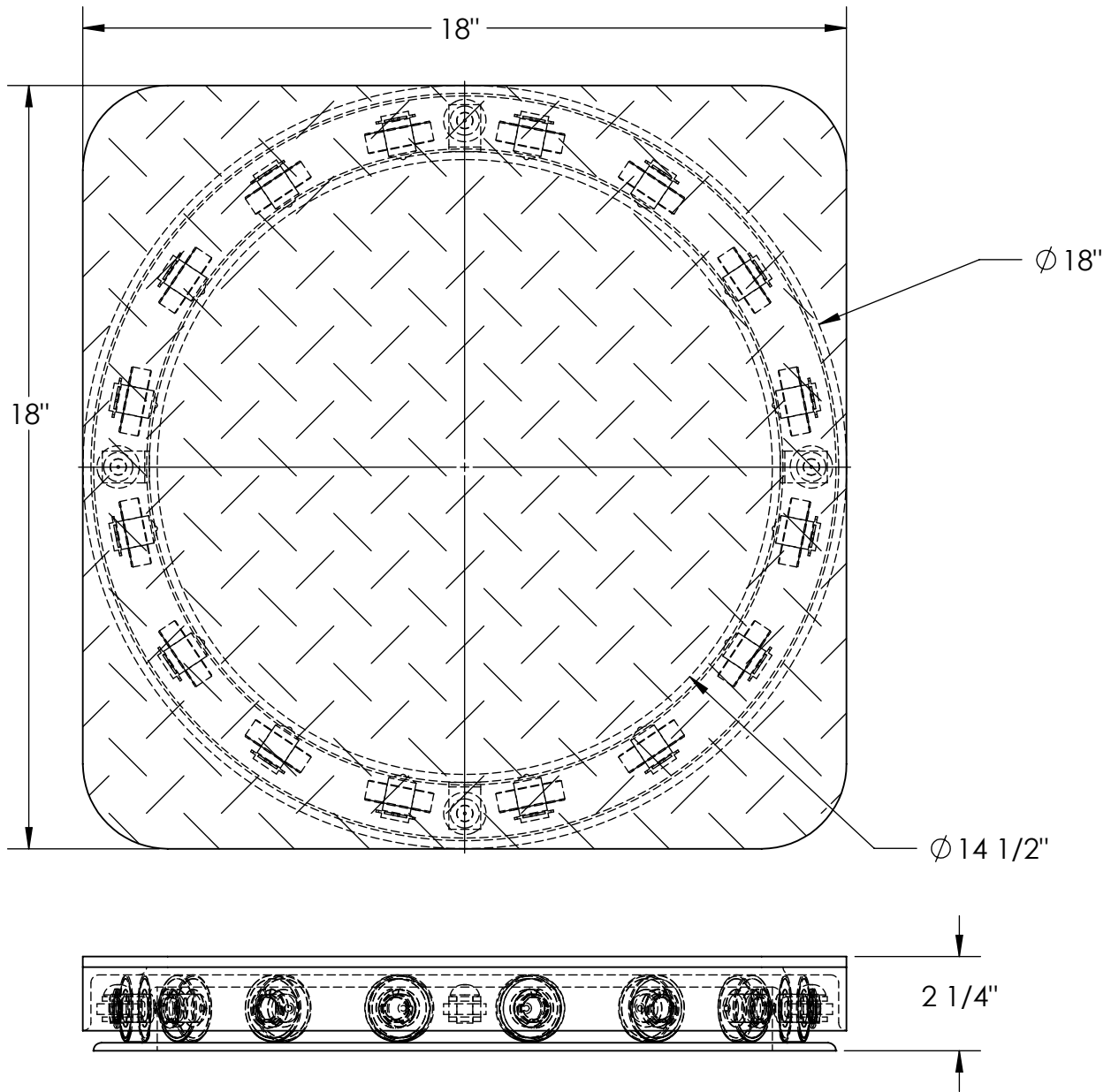

ALL GRAPHICS PROVIDED ARE FOR REFERENCE ONLY. IF CERTAIN DIMENSIONS ARE CRITICAL PLEASE VERIFY THOSE DIMENSIONS WITH YOUR SALESPERSON

DIMENSION TOLERANCE ± 1/4"

STANDARD FEATURES

- MODEL NUMBER: CA-18-2-TP-STP
- CAPACITY: 2,000 LBS
- LEVEL HEIGHT: 2 1/4"
- DIAMETER: 18"
- NUMBER OF BEARINGS: 16
- FEATURES SQUARE TREADPLATE TOP PLATE
- TOP PLATE IS 18" x 18"
- DURABLE LIQUID PAINT BLUE FINISH

SPECIAL FEATURES

NONE

A P P R O V A L	I, THE UNDERSIGNED, AGREE THAT THE PRODUCT AS REPRESENTED SATISFIES DESIGN AND DIMENSION REQUIREMENTS. I ALSO ACKNOWLEDGE MY DUTY TO CONFIRM PRODUCT AND INSTALLATION COMPLIANCE WITH ALL APPLICABLE FEDERAL, STATE AND LOCAL REGULATIONS AND STANDARDS.	
	UNITS REQUIRING APPROVAL DRAWINGS OR MODIFIED ARE NON-RETURNABLE	
	[] As drawn	[] As marked
	Signed: _____ Date: _____	
Printed Name: _____		
LEAD TIME WILL START UPON RECEIPT OF SIGNED APPROVAL DRAWING		

DISTRIBUTOR'S NAME:		P.O.#
VESTIL MANUFACTURING		X
DRAWN BY: TJM		DATE: 09/20/22
REFERENCE: X		SCALE: 1:4
QUOTED LEAD TIME: X	QUOTE # X	SALES: X
		FILE NAME: 20-007-207