

# MANUAL CAROUSEL - CA-18-2

APPROX WEIGHT: 20.46 lbs.  
DOES NOT INCLUDE WEIGHT OF POWER OR PACKAGING!!!

\*\*\*ANY ADDITIONS, DELETIONS, OR OMISSIONS MUST BE CORRECTED ON THIS DRAWING AS THIS DRAWING WILL BE CONSIDERED ALL INCLUSIVE\*\*\*

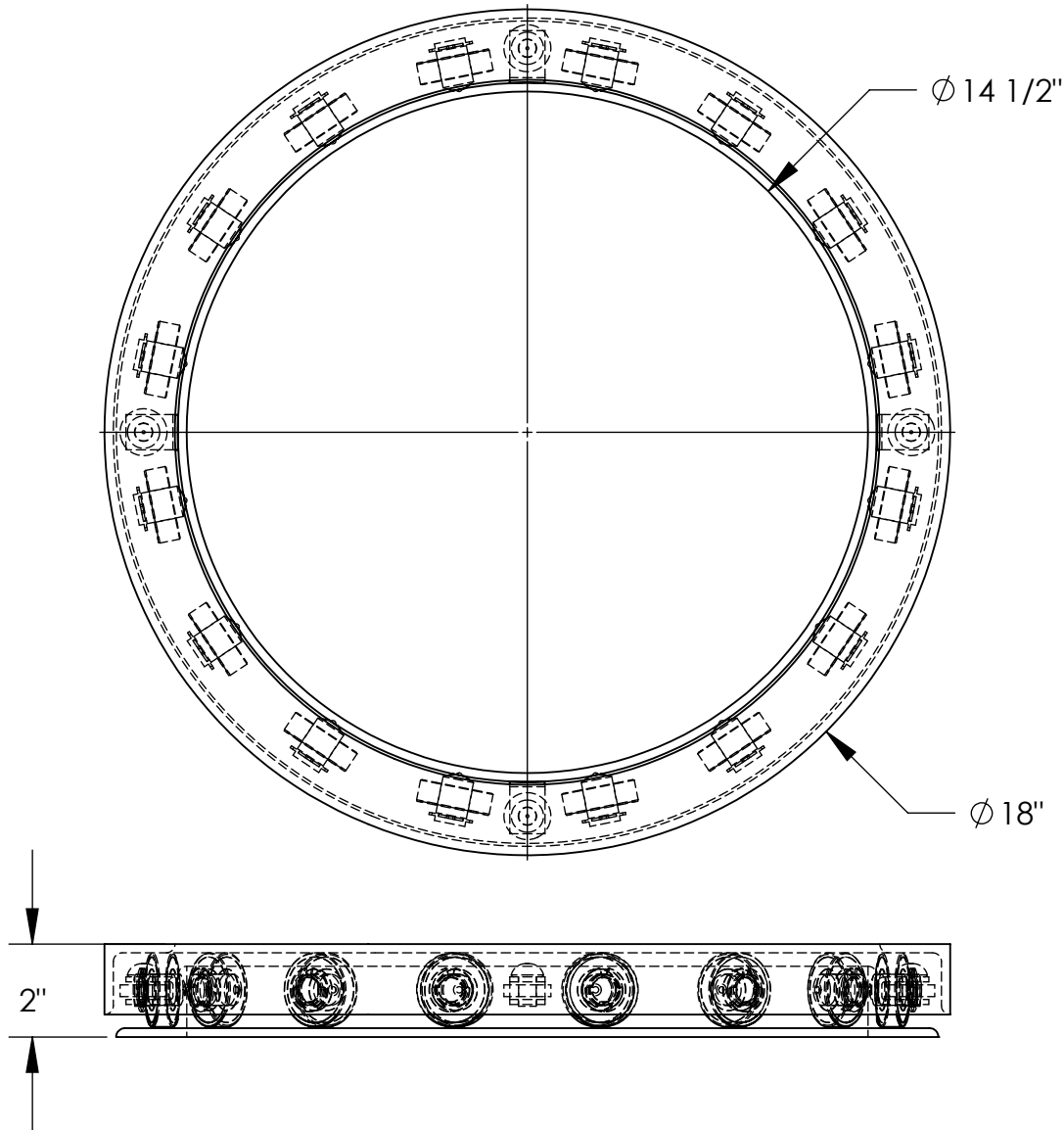

ALL GRAPHICS PROVIDED ARE FOR REFERENCE ONLY. IF CERTAIN DIMENSIONS ARE CRITICAL PLEASE VERIFY THOSE DIMENSIONS WITH YOUR SALESPERSON DIMENSION TOLERANCE ± 1/4"

## STANDARD FEATURES

- MODEL NUMBER: CA-18-2
- CAPACITY: 2,000 LBS
- LEVEL HEIGHT: 2"
- DIAMETER: 18"
- NUMBER OF BEARINGS: 16
- STEEL CONSTRUCTION
- TOUGH BAKED IN POWDERCOAT BLUE FINISH

## SPECIAL FEATURES

NONE

<b>A P P R O V A L</b>	I, THE UNDERSIGNED, AGREE THAT THE PRODUCT AS REPRESENTED SATISFIES DESIGN AND DIMENSION REQUIREMENTS. I ALSO ACKNOWLEDGE MY DUTY TO CONFIRM PRODUCT AND INSTALLATION COMPLIANCE WITH ALL APPLICABLE FEDERAL, STATE AND LOCAL REGULATIONS AND STANDARDS.	
	<b>UNITS REQUIRING APPROVAL DRAWINGS OR MODIFIED ARE NON-RETURNABLE</b>	
	<input type="checkbox"/> As drawn	<input type="checkbox"/> As marked
	Signed: _____	Date: _____
	Printed Name: _____	
	<i>LEAD TIME WILL START UPON RECEIPT OF SIGNED APPROVAL DRAWING</i>	

DISTRIBUTOR'S NAME:		P.O.#
<b>VESTIL MANUFACTURING</b>		X
DRAWN BY: X		W.O.#
DATE: XX/XX/XX		X
REFERENCE: X		SALES: X
QUOTED LEAD TIME: X		FILE NAME:
QUOTE # X		20-007-049
SCALE: 1:4		