

# MANUAL CAROUSEL WITH TOP PLATE - CA-24-4-TP-STP

\*\*\*ANY ADDITIONS, DELETIONS, OR OMISSIONS MUST BE CORRECTED ON THIS DRAWING AS THIS DRAWING WILL BE CONSIDERED ALL INCLUSIVE\*\*\*  
 APPROX WEIGHT: 69.04 lbs.  
 DOES NOT INCLUDE WEIGHT OF POWER OR PACKAGING!!!

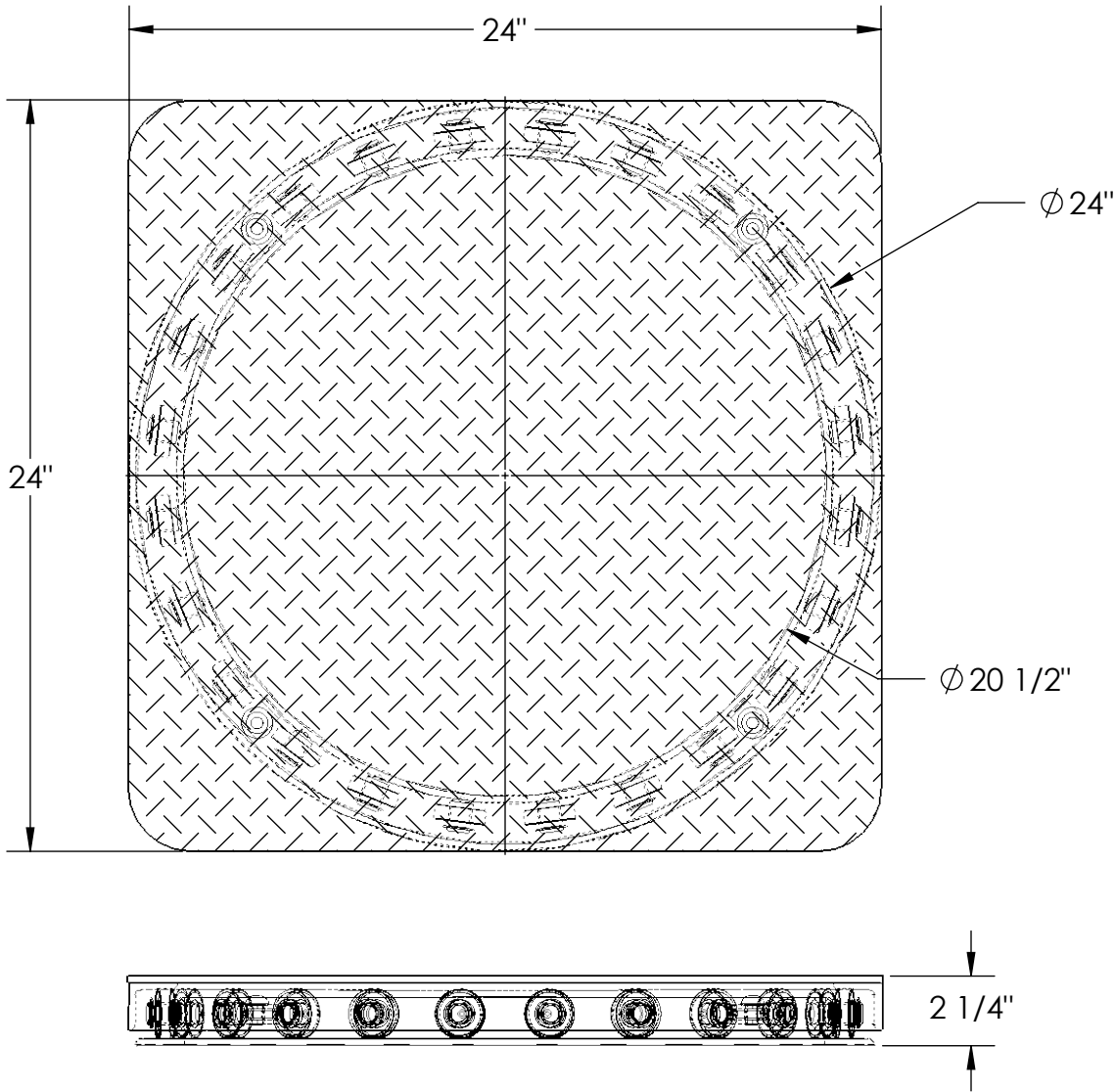

ALL GRAPHICS PROVIDED ARE FOR REFERENCE ONLY. IF CERTAIN DIMENSIONS ARE CRITICAL PLEASE VERIFY THOSE DIMENSIONS WITH YOUR SALESPERSON

**DIMENSION TOLERANCE ± 1/4"**

## STANDARD FEATURES

- MODEL NUMBER: CA-24-4-TP-STP
- CAPACITY: 4,000 LBS
- LEVEL HEIGHT: 2 1/4"
- DIAMETER: 24"
- NUMBER OF BEARINGS: 24
- FEATURES SQUARE TREADPLATE TOP PLATE
- TOP PLATE IS 24" x 24"
- DURABLE LIQUID PAINT BLUE FINISH

## SPECIAL FEATURES

NONE

<b>A P P R O V A L</b>	I, THE UNDERSIGNED, AGREE THAT THE PRODUCT AS REPRESENTED SATISFIES DESIGN AND DIMENSION REQUIREMENTS. I ALSO ACKNOWLEDGE MY DUTY TO CONFIRM PRODUCT AND INSTALLATION COMPLIANCE WITH ALL APPLICABLE FEDERAL, STATE AND LOCAL REGULATIONS AND STANDARDS.	
	<b>UNITS REQUIRING APPROVAL DRAWINGS OR MODIFIED ARE NON-RETURNABLE</b>	
	[ ] As drawn [ ] As marked	
	Signed: _____ Date: _____	
Printed Name: _____		
<i>LEAD TIME WILL START UPON RECEIPT OF SIGNED APPROVAL DRAWING</i>		

DISTRIBUTOR'S NAME:		P.O.#
VESTIL MANUFACTURING		X
DRAWN BY: TJM		DATE: 09/20/22
DATE: 09/20/22		SALES: X
REFERENCE: X	SCALE: 1:6	FILE NAME:
QUOTED LEAD TIME: X	QUOTE # X	20-007-215