

MANUAL CAROUSEL WITH TOP PLATE - CA-40-6-TP-RTP

ANY ADDITIONS, DELETIONS, OR OMISSIONS MUST BE CORRECTED ON THIS DRAWING AS THIS DRAWING WILL BE CONSIDERED ALL INCLUSIVE

APPROX WEIGHT: 134.80 lbs.

DOES NOT INCLUDE WEIGHT OF POWER OR PACKAGING!!!

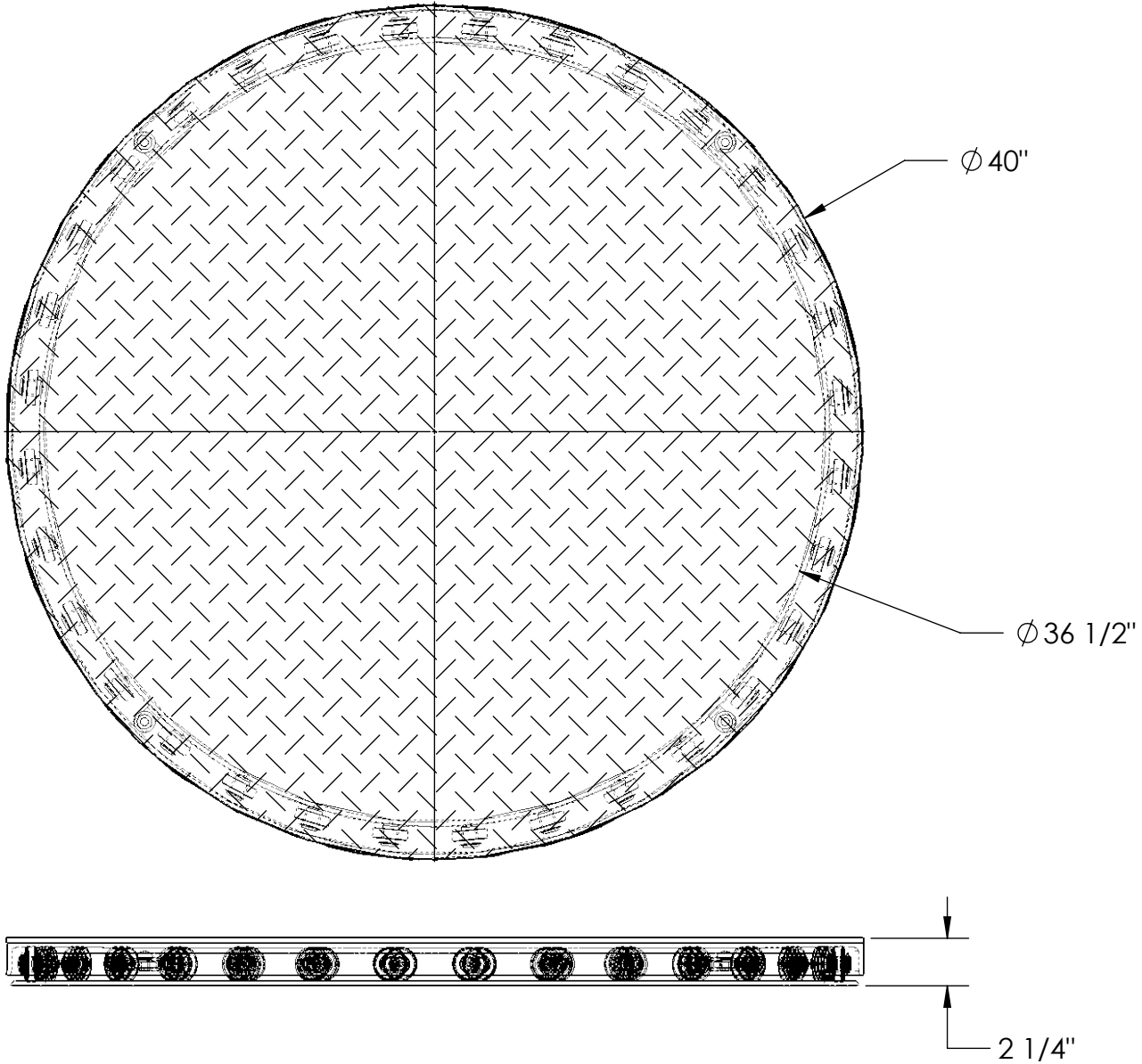

DIMENSION TOLERANCE $\pm 1/4"$

ALL GRAPHICS PROVIDED ARE FOR REFERENCE ONLY. IF CERTAIN DIMENSIONS ARE CRITICAL PLEASE VERIFY THOSE DIMENSIONS WITH YOUR SALESPERSON

STANDARD FEATURES

- MODEL NUMBER: CA-40-6-TP-RTP
- CAPACITY: 6,000 LBS
- LEVEL HEIGHT: 2 1/4"
- DIAMETER: 40"
- NUMBER OF BEARINGS: 32
- FEATURES ROUND TREADPLATE TOP PLATE
- TOP PLATE IS $\varnothing 40"$
- DURABLE LIQUID PAINT BLUE FINISH

SPECIAL FEATURES

**A
P
P
R
O
V
A
L**

I, THE UNDERSIGNED, AGREE THAT THE PRODUCT AS REPRESENTED SATISFIES DESIGN AND DIMENSION REQUIREMENTS. I ALSO ACKNOWLEDGE MY DUTY TO CONFIRM PRODUCT AND INSTALLATION COMPLIANCE WITH ALL APPLICABLE FEDERAL, STATE AND LOCAL REGULATIONS AND STANDARDS.
UNITS REQUIRING APPROVAL DRAWINGS OR MODIFIED ARE NON-RETURNABLE
 As drawn As marked

Signed: _____ Date: _____

Printed Name: _____

LEAD TIME WILL START UPON RECEIPT OF SIGNED APPROVAL DRAWING

DISTRIBUTOR'S NAME:		P.O.#
VESTIL MANUFACTURING		X
DRAWN BY: TJM		DATE: 09/26/22
DATE: 09/26/22		SALES: X
REFERENCE: X	SCALE: 1:8	FILE NAME:
QUOTED LEAD TIME: X	QUOTE # X	20-007-241