

MANUAL CAROUSEL WITH TOP PLATE - CA-48-6-TP-SSM

ANY ADDITIONS, DELETIONS, OR OMISSIONS MUST BE CORRECTED ON THIS DRAWING AS THIS DRAWING WILL BE CONSIDERED ALL INCLUSIVE
 APPROX WEIGHT: 216.22 lbs.
 DOES NOT INCLUDE WEIGHT OF POWER OR PACKAGING!!!

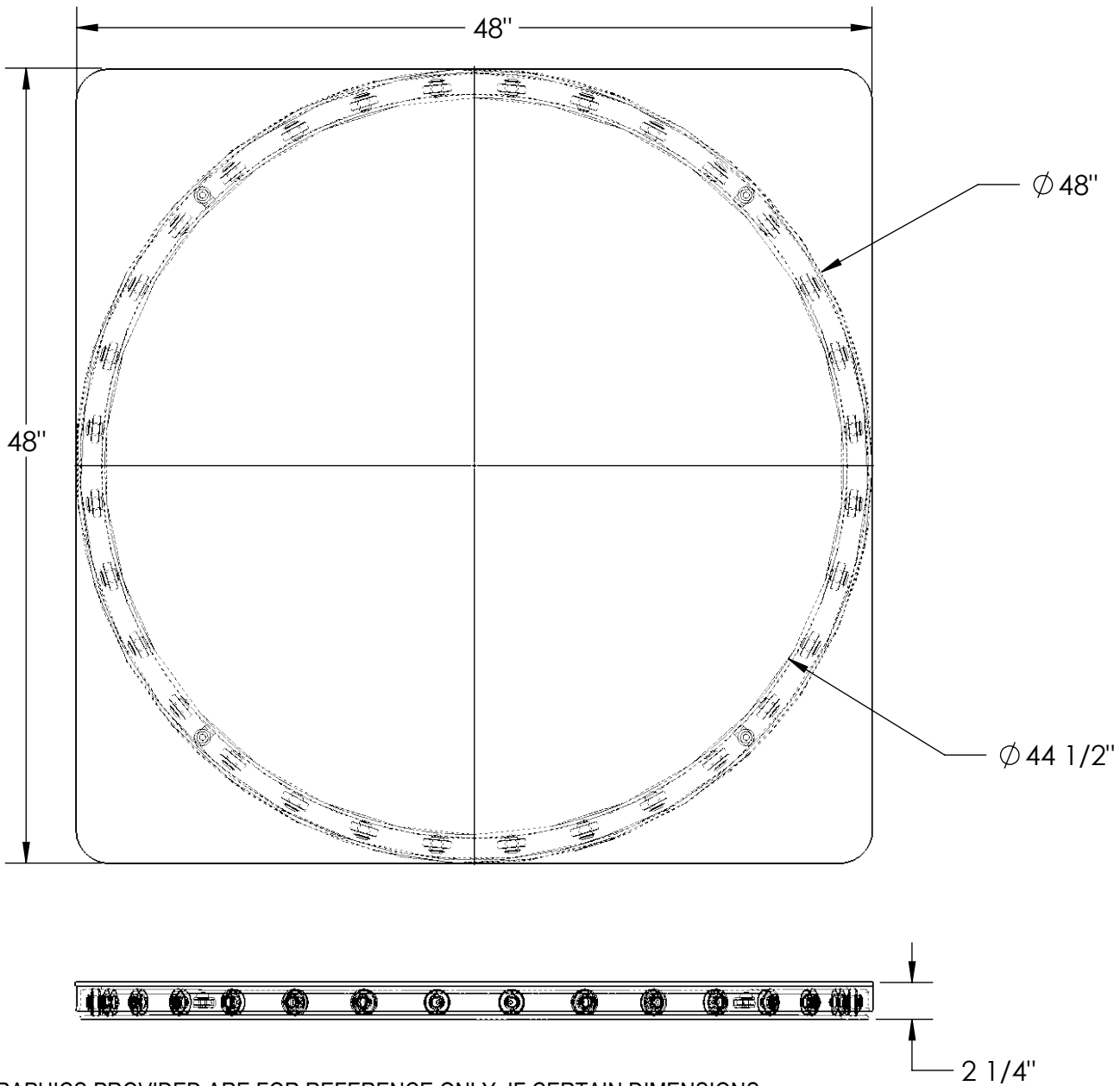

ALL GRAPHICS PROVIDED ARE FOR REFERENCE ONLY. IF CERTAIN DIMENSIONS ARE CRITICAL PLEASE VERIFY THOSE DIMENSIONS WITH YOUR SALESPERSON

DIMENSION TOLERANCE $\pm 1/4"$

STANDARD FEATURES

- MODEL NUMBER: CA-48-6-TP-SSM
- CAPACITY: 6,000 LBS
- LEVEL HEIGHT: 2 1/4"
- DIAMETER: 48"
- NUMBER OF BEARINGS: 32
- FEATURES SQUARE SMOOTH TOP PLATE
- TOP PLATE IS 48" x 48"
- DURABLE LIQUID PAINT BLUE FINISH

SPECIAL FEATURES

NONE

APPROVAL	I, THE UNDERSIGNED, AGREE THAT THE PRODUCT AS REPRESENTED SATISFIES DESIGN AND DIMENSION REQUIREMENTS. I ALSO ACKNOWLEDGE MY DUTY TO CONFIRM PRODUCT AND INSTALLATION COMPLIANCE WITH ALL APPLICABLE FEDERAL, STATE AND LOCAL REGULATIONS AND STANDARDS.	
	UNITS REQUIRING APPROVAL DRAWINGS OR MODIFIED ARE NON-RETURNABLE	
	[] As drawn [] As marked	
	Signed: _____	Date: _____
Printed Name: _____		
LEAD TIME WILL START UPON RECEIPT OF SIGNED APPROVAL DRAWING		

DISTRIBUTOR'S NAME:		P.O.#
VESTIL MANUFACTURING		X
DRAWN BY: TJM		DATE: 09/26/22
REFERENCE: X		SALES: X
QUOTED LEAD TIME: X		SCALE: 1:10
QUOTE # X		FILE NAME: 20-007-254