

T & S EQUIPMENT COMPANY
 2999 North Wayne St., Angola, IN 46703 USA
 Ph: 219-665-9521 Fax 219-665-1339
 E-mail: sales@tseq.com Website: www.tseq.com

Revised 05-01

A company dedicated to solving ergonomic and material handling problems since 1955.

OWNERS MANUAL

**ALUMINUM CONVERTIBLE HAND TRUCK
MODEL CAHT-500**

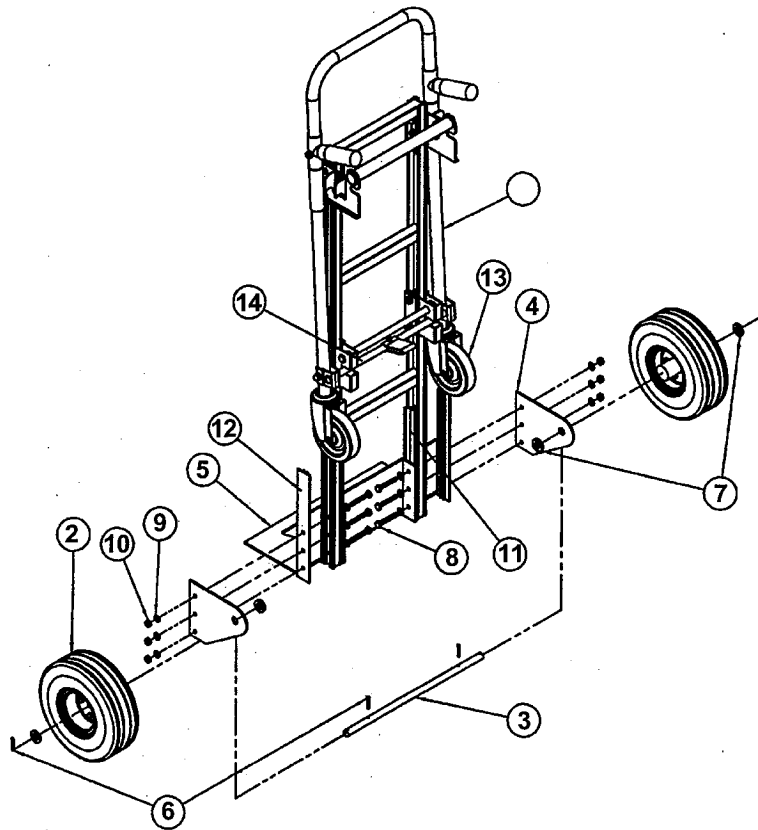
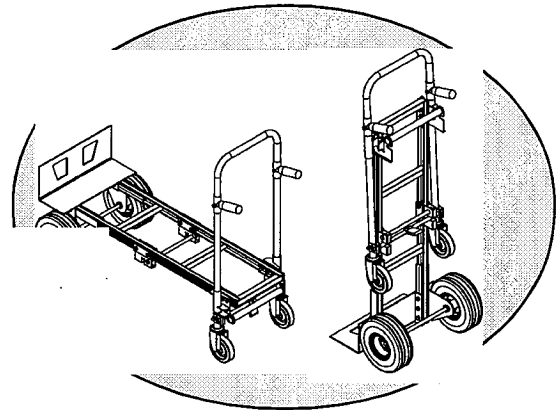

**500 lb.
CAPACITY**

ITEM NO.	DESCRIPTION	PART NO.	QTY.
1	Main Body	CAHT-1	1
2	Pneumatic, Tires 10 x 3-1/4	CAHT-2	2
3	Axle - 5/8 x 17-1/2	CAHT-3	1
4	Axle Bracket	CAHT-4	2
5	Platform	CAHT-5	1
6	Cotter Keys 1/8"	CAHT-6	4
7	Spacer M-16	CAHT-7	4
8	Bolts M8 x 1.25 x 55	CAHT-8	6
9	Washers M8	CAHT-9	6
10	Lock Nut M8 x 1.25	CAHT-10	6
11	Inner Brace	CAHT-11	2
12	Outer Brace	CAHT-12	2
13	Swivel Casters	CAHT-13	2
14	Latch Assembly	CAHT-14	1

RECEIVING INSTRUCTIONS

Every unit is thoroughly tested and inspected prior to shipment. However, it is possible that the unit may incur damage during transit. If damage is noticed when unloading, make a note of it on the **BILL OF LADING**. Remove all packing and strapping material, then inspect the unit again for damage. **IF DAMAGE IS EVIDENT, FILE A CLAIM WITH THE CARRIER IMMEDIATELY!**

WARRANTY

This product is warranted for 90 DAYS from date of purchase to be free of manufacturing defects in material and workmanship. The manufacturer's obligation hereunder is limited to repairing such products during the warranty period, provided the product is sent prepaid back to the factory.

This warranty does not cover normal wear of parts or damage resulting from any of the following: negligent use or misuse of the product, use or application contrary to installation instructions, or disassembly, repair or alteration by any person prior to authorization from a factory representative.

Material Handling Problem Solvers

Time is money. Increased productivity equals greater profitability, cost minimization and worker compatibility. Ergonomic products will assist you with your production and safety goals.

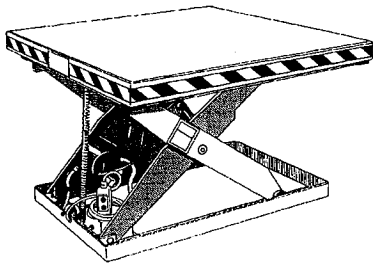

**ELECTRIC HYDRAULIC
SCISSOR LIFT TABLE**

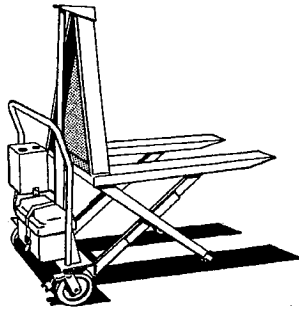

**HIGH RISE
LIFT TRUCK**

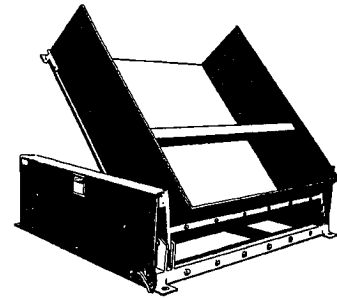

GROUND TILTER

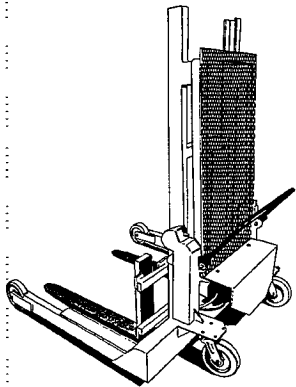

**DC POWERED
PALLET MASTER/SERVER**

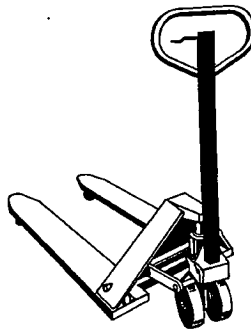

**DELUXE
PALLET TRUCK**

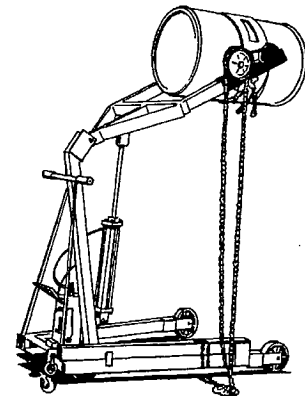

**HYDRAULIC DRUM
CARRIER/ROTATOR**

LIMITED WARRANTY

Vestil Manufacturing Corporation ("Vestil") warrants this product to be free of defects in material and workmanship during the warranty period. *Our warranty obligation is to provide a replacement for a defective original part if the part is covered by the warranty, after we receive a proper request from the warrantee (you) for warranty service.*

Who may request service?

Only a warrantee may request service. *You are a warrantee if* you purchased the product from Vestil or from an authorized distributor AND Vestil has been fully paid.

What is an "original part"?

An original part is a part used to make the product as shipped to the warrantee.

What is a "proper request"?

A request for warranty service is proper if Vestil receives: 1) a photocopy of the Customer Invoice that displays the shipping date; AND 2) a written request for warranty service including your name and phone number. Send requests by any of the following methods:

Mail
Vestil Manufacturing Corporation
2999 North Wayne Street, PO Box 507
Angola, IN 46703

Fax
(260) 665-1339
Phone
(260) 665-7586

Email
sales@vestil.com

In the written request, list the parts believed to be defective and include the address where replacements should be delivered.

What is covered under the warranty?

After Vestil receives your request for warranty service, an authorized representative will contact you to determine whether your claim is covered by the warranty. Before providing warranty service, Vestil may require you to send the entire product, or just the defective part or parts, to its facility in Angola, IN. The warranty covers defects in the following *original* dynamic components: motors, hydraulic pumps, electronic controllers, switches and cylinders. It also covers defects in *original* parts that wear under normal usage conditions ("wearing parts"): bearings, hoses, wheels, seals, brushes, batteries, and the battery charger.

How long is the warranty period?

The warranty period for original components is 15 days. The warranty period begins on the date when Vestil ships the product to the warrantee. If the product was purchased from an authorized distributor, the period begins when the distributor ships the product. Vestil may extend the warranty period for products shipped from authorized distributors by *up to* 30 days to account for shipping time.

If a defective part is covered by the warranty, what will Vestil do to correct the problem?

Vestil will provide an appropriate replacement for any *covered* part. An authorized representative of Vestil will contact you to discuss your claim.

What is not covered by the warranty?

1. Labor;
2. Freight;
3. Occurrence of any of the following, which automatically voids the warranty:
 - Product misuse;
 - Negligent operation or repair;
 - Corrosion or use in corrosive environments;
 - Inadequate or improper maintenance;
 - Damage sustained during shipping;
 - Collisions or other incidental contacts causing damage to the product;
 - Unauthorized modifications: DO NOT modify the product IN ANY WAY without first receiving written authorization from Vestil. Modification(s) might make the product unsafe to use or might cause excessive and/or abnormal wear.

Do any other warranties apply to the product?

Vestil Manufacturing Corp. makes no other express warranties. All implied warranties are disclaimed to the extent allowed by law. Any implied warranty not disclaimed is limited in scope to the terms of this Limited Warranty.

