

# LOW PROFILE FOOT PUMP HYDRAULIC SCISSOR LIFT CART - CART-LP-2000-4242-FP

APPROX WEIGHT: 479 lbs.  
DOES NOT INCLUDE WEIGHT OF POWER OR PACKAGING!!!

\*\*\* ANY ADDITIONS, DELETIONS, OR OMISSIONS MUST BE CORRECTED ON THIS DRAWING AS THIS DRAWING WILL BE CONSIDERED ALL INCLUSIVE \*\*\*  
ALL GRAPHICS PROVIDED ARE FOR REFERENCE ONLY. IF CERTAIN DIMENSIONS ARE CRITICAL PLEASE VERIFY THOSE DIMENSIONS WITH YOUR SALESPERSON

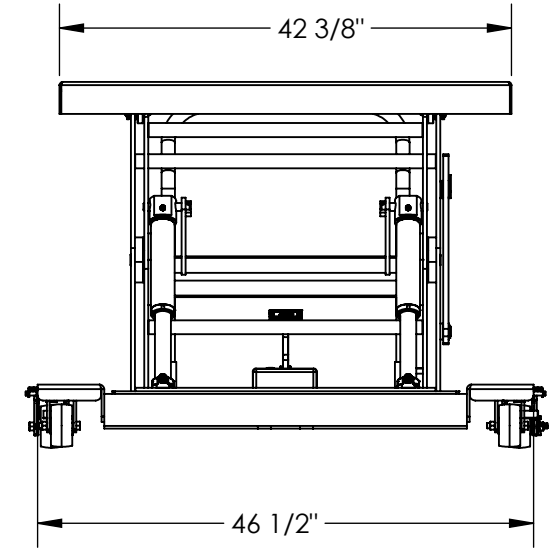
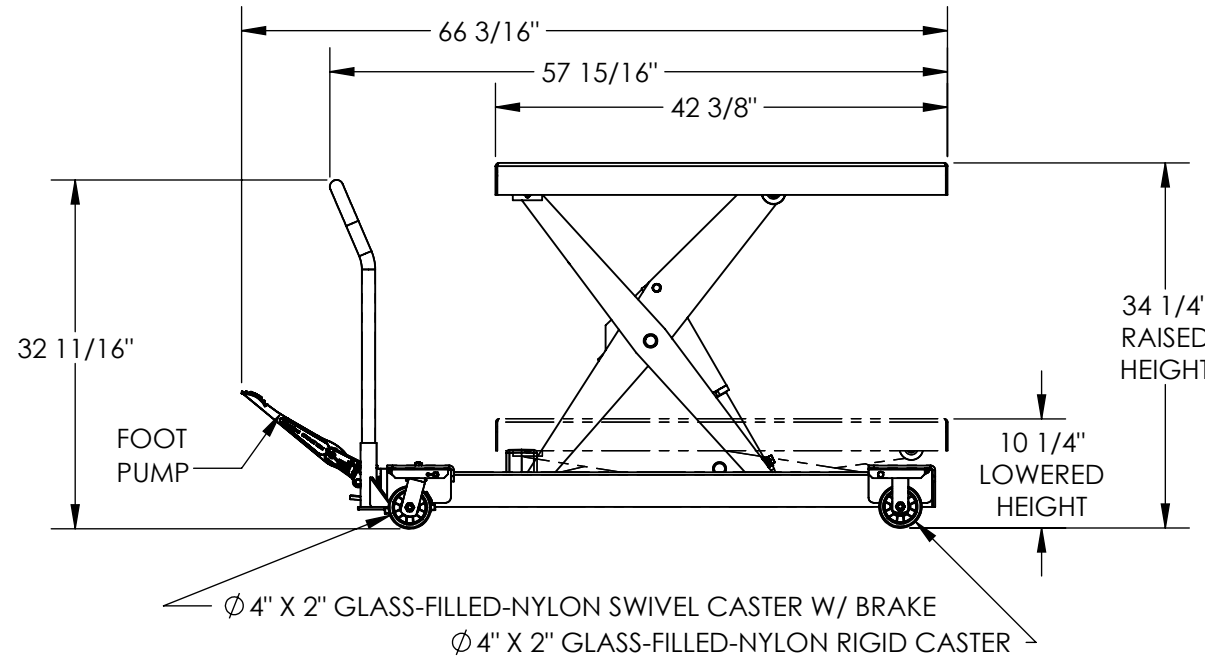

DECK TOLERANCE  $\pm 1/2$ "  
TABLE HEIGHT TOLERANCES  $\pm 1/2$ "  
DECK FLATNESS  $\pm 1/4$ "

DIMENSION TOLERANCE  $\pm 1/4$ "

## STANDARD FEATURES

- MODEL NUMBER IS CART-LP-2000-4242-FP
- OVERALL WIDTH: 46 1/2"
- USABLE WIDTH: 42 3/8"
- OVERALL LENGTH: 66 3/16"
- USABLE LENGTH: 42 3/8"
- RAISED HEIGHT: 34 1/4"
- LOWERED HEIGHT: 10 1/4"

- $\phi$  4" X 2" GLASS-FILLED-NYLON RIGID CASTER
- $\phi$  4" X 2" GLASS-FILLED-NYLON SWIVEL CASTER W/ BRAKE
- TABLE CAPACITY (EVENLY DISTRIBUTED)
- MAX CAPACITY IS 2,000 LBS
- SAFETY MAINTENANCE PROPS, DISPLACEMENT
- STYLE CYLINDERS INSTALLED ROD DOWN
- EMERGENCY SAFETY STOP HYDRAULIC FUSES
- UPPER TRAVEL LIMIT SWITCH
- DURABLE LIQUID PAINT BLUE FINISH

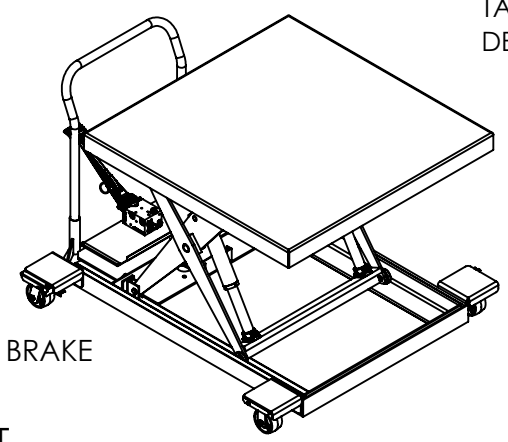

## SPECIAL FEATURES

NONE

<b>A P P R O V A L</b>	I, THE UNDERSIGNED, AGREE THAT THE PRODUCT AS REPRESENTED SATISFIES DESIGN AND DIMENSION REQUIREMENTS. I ALSO ACKNOWLEDGE MY DUTY TO CONFIRM PRODUCT AND INSTALLATION COMPLIANCE WITH ALL APPLICABLE FEDERAL, STATE AND LOCAL REGULATIONS AND STANDARDS.	
	<b>UNITS REQUIRING APPROVAL DRAWINGS OR MODIFIED ARE NON-RETURNABLE</b>	
	[ ] As drawn      [ ] As marked	
	Signed: _____ Date: _____	
Printed Name: _____		
<i>LEAD TIME WILL START UPON RECEIPT OF SIGNED APPROVAL DRAWING</i>		

DISTRIBUTOR'S NAME: <b>VESTIL MANUFACTURING</b>		P.O.# X
DRAWN BY: CRA		W.O.# X
DATE: 06/14/2019		SALES: X
REFERENCE: X		SCALE: 1:18
QUOTED LEAD TIME: X		FILE NAME: 01-007-404
QUOTE # X		