

# COUNTER BALANCED FLOOR CRANE - CBFC-2000-DC

\*\*\* ANY ADDITIONS, DELETIONS, OR OMISSIONS MUST BE CORRECTED ON THIS DRAWING AS THIS DRAWING WILL BE CONSIDERED ALL INCLUSIVE \*\*\*

ALL GRAPHICS PROVIDED ARE FOR REFERENCE ONLY. IF CERTAIN DIMENSIONS ARE CRITICAL PLEASE VERIFY THOSE DIMENSIONS WITH YOUR SALESPERSON

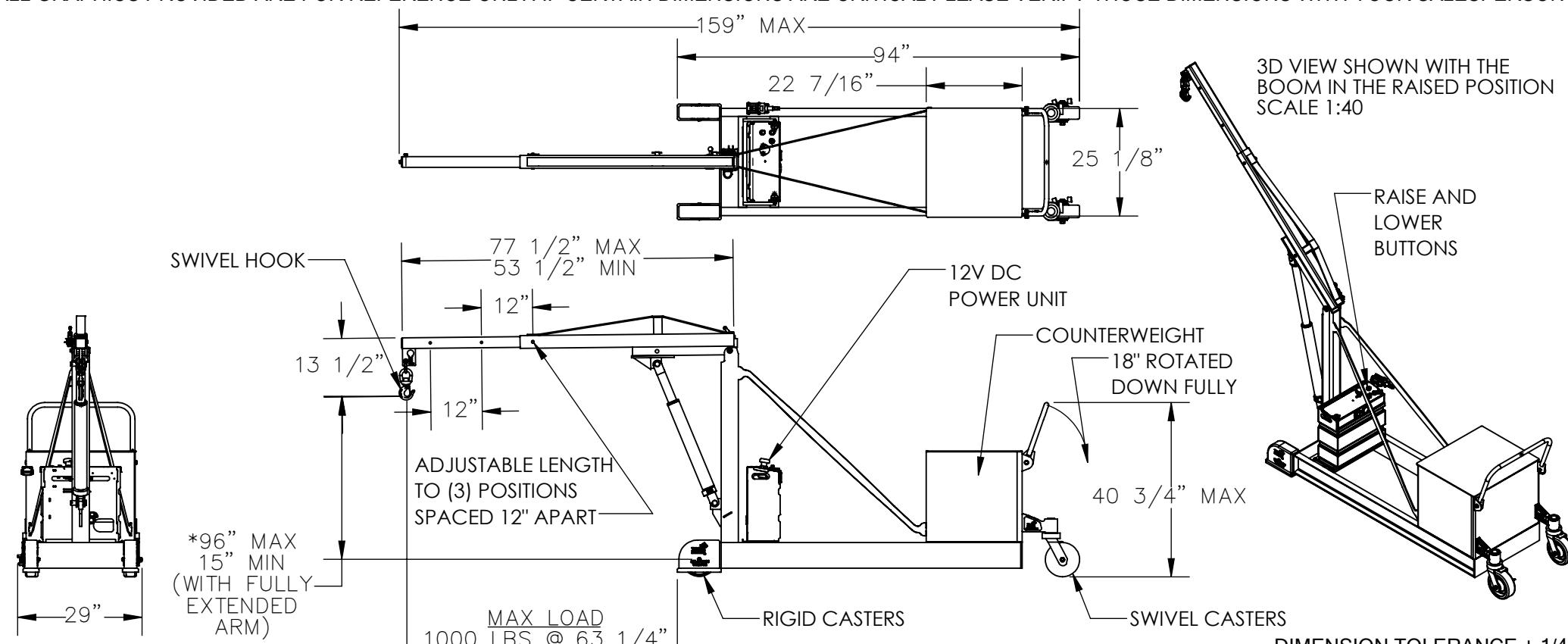

\*WHEN BOOM IS FULLY RETRACTED AND THE CYLINDER IS FULLY RETRACTED HOOK HEIGHT IS 23 3/16"

\*WHEN BOOM IS FULLY RETRACTED AND THE CYLINDER IS FULLY EXTENDED HOOK HEIGHT IS 78 3/16"

## STANDARD FEATURES

- MODEL NUMBER IS: CBFC-2000-DC
- OVERALL WIDTH IS: 29"
- OVERALL LENGTH IS: 159"
- OVERALL HEIGHT IS: 107 1/4"
- MAX CAPACITY IS: 2,000 LBS
- 12V DC POWER UNIT W/ ON-BOARD CHARGER & BATTERY CHARGE INDICATOR
- UNIT IS DURABLE LIQUID PAINT BLUE FINISH
- INNER BOOM IS DURABLE LIQUID PAINT YELLOW FINISH
- APPROX. SHIPPING WEIGHT: 2,356 LBS

MAX LOAD	
1000 LBS	@ 63 1/4"
1500 LBS	@ 51 1/4"
2000 LBS	@ 39 1/4"

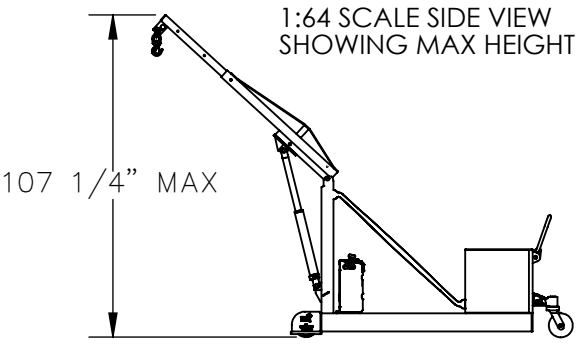

## SPECIAL FEATURES

NONE

**APPROVAL**

I, THE UNDERSIGNED, AGREE THAT THE PRODUCT AS REPRESENTED SATISFIES DESIGN AND DIMENSION REQUIREMENTS. I ALSO ACKNOWLEDGE MY DUTY TO CONFIRM PRODUCT AND INSTALLATION COMPLIANCE WITH ALL APPLICABLE FEDERAL, STATE AND LOCAL REGULATIONS AND STANDARDS.

**UNITS REQUIRING APPROVAL DRAWINGS OR MODIFIED ARE NON-RETURNABLE**

[ ] As drawn [ ] As marked

Signed: \_\_\_\_\_ Date: \_\_\_\_\_

Printed Name: \_\_\_\_\_

LEAD TIME WILL START UPON RECEIPT OF SIGNED APPROVAL DRAWING

DISTRIBUTOR'S NAME:		P.O.#
VESTIL MANUFACTURING		X
DRAWN BY: JGP	DATE: 2/10/2022	W.O.#
REFERENCE: X	SCALE: 1:34	X
QUOTED LEAD TIME: X	QUOTE #	SALES: X
	X	FILE NAME:
		16-007-545