

# COUNTER BALANCED FLOOR CRANE - CBFC-500-DC

\*\*\* ANY ADDITIONS, DELETIONS, OR OMISSIONS MUST BE CORRECTED ON THIS DRAWING AS THIS DRAWING WILL BE CONSIDERED ALL INCLUSIVE \*\*\*  
 ALL GRAPHICS PROVIDED ARE FOR REFERENCE ONLY. IF CERTAIN DIMENSIONS ARE CRITICAL PLEASE VERIFY THOSE DIMENSIONS WITH YOUR SALESPERSON

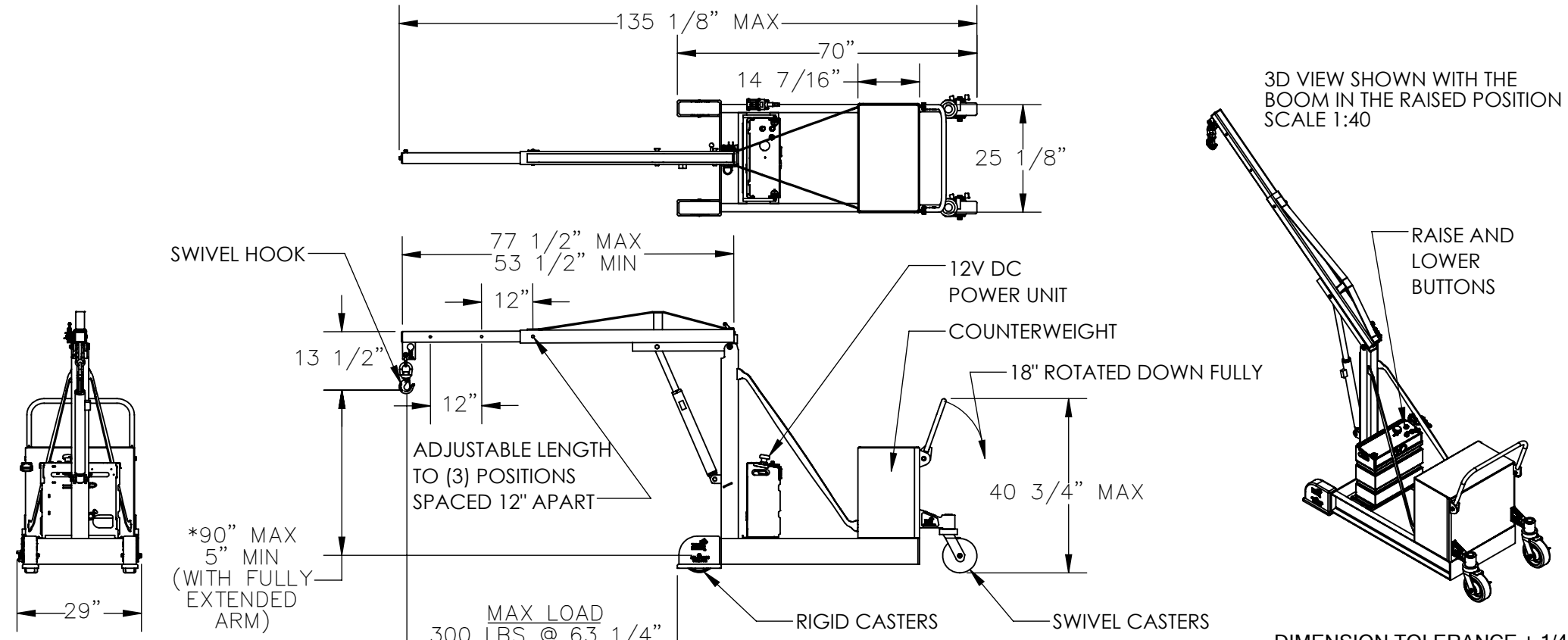

**MAX LOAD**

300 LBS	@	63 1/4"
400 LBS	@	51 1/4"
500 LBS	@	39 1/4"

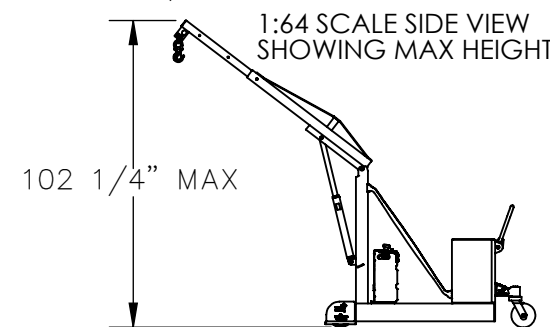

**SPECIAL FEATURES**  
 NONE

\*WHEN BOOM IS FULLY RETRACTED AND THE CYLINDER IS FULLY RETRACTED HOOK HEIGHT IS 16 7/16"

\*WHEN BOOM IS FULLY RETRACTED AND THE CYLINDER IS FULLY EXTENDED HOOK HEIGHT IS 74 7/16"

**STANDARD FEATURES**

- MODEL NUMBER IS: CBFC-500-DC
- OVERALL WIDTH IS: 29"
- OVERALL LENGTH IS: 135 1/8"
- OVERALL HEIGHT IS: 102 1/4"
- MAX CAPACITY IS: 500 LBS
- 12V DC POWER UNIT W/ ON-BOARD CHARGER & BATTERY CHARGE INDICATOR
- UNIT IS DURABLE LIQUID PAINT BLUE FINISH
- INNER BOOM IS DURABLE LIQUID PAINT YELLOW FINISH
- APPROX. SHIPPING WEIGHT: 1,319 LBS

**APPROVAL**

I, THE UNDERSIGNED, AGREE THAT THE PRODUCT AS REPRESENTED SATISFIES DESIGN AND DIMENSION REQUIREMENTS. I ALSO ACKNOWLEDGE MY DUTY TO CONFIRM PRODUCT AND INSTALLATION COMPLIANCE WITH ALL APPLICABLE FEDERAL, STATE AND LOCAL REGULATIONS AND STANDARDS.  
**UNITS REQUIRING APPROVAL DRAWINGS OR MODIFIED ARE NON-RETURNABLE**  
 As drawn     As marked

Signed: \_\_\_\_\_ Date: \_\_\_\_\_  
 Printed Name: \_\_\_\_\_

**LEAD TIME WILL START UPON RECEIPT OF SIGNED APPROVAL DRAWING**

DISTRIBUTOR'S NAME:		P.O.#
VESTIL MANUFACTURING		X
DRAWN BY: JGP		W.O.#
DATE: 2/10/2022		X
REFERENCE: X	SCALE: 1:34	SALES: X
QUOTED LEAD TIME: X	QUOTE # X	FILE NAME:
		16-007-543