

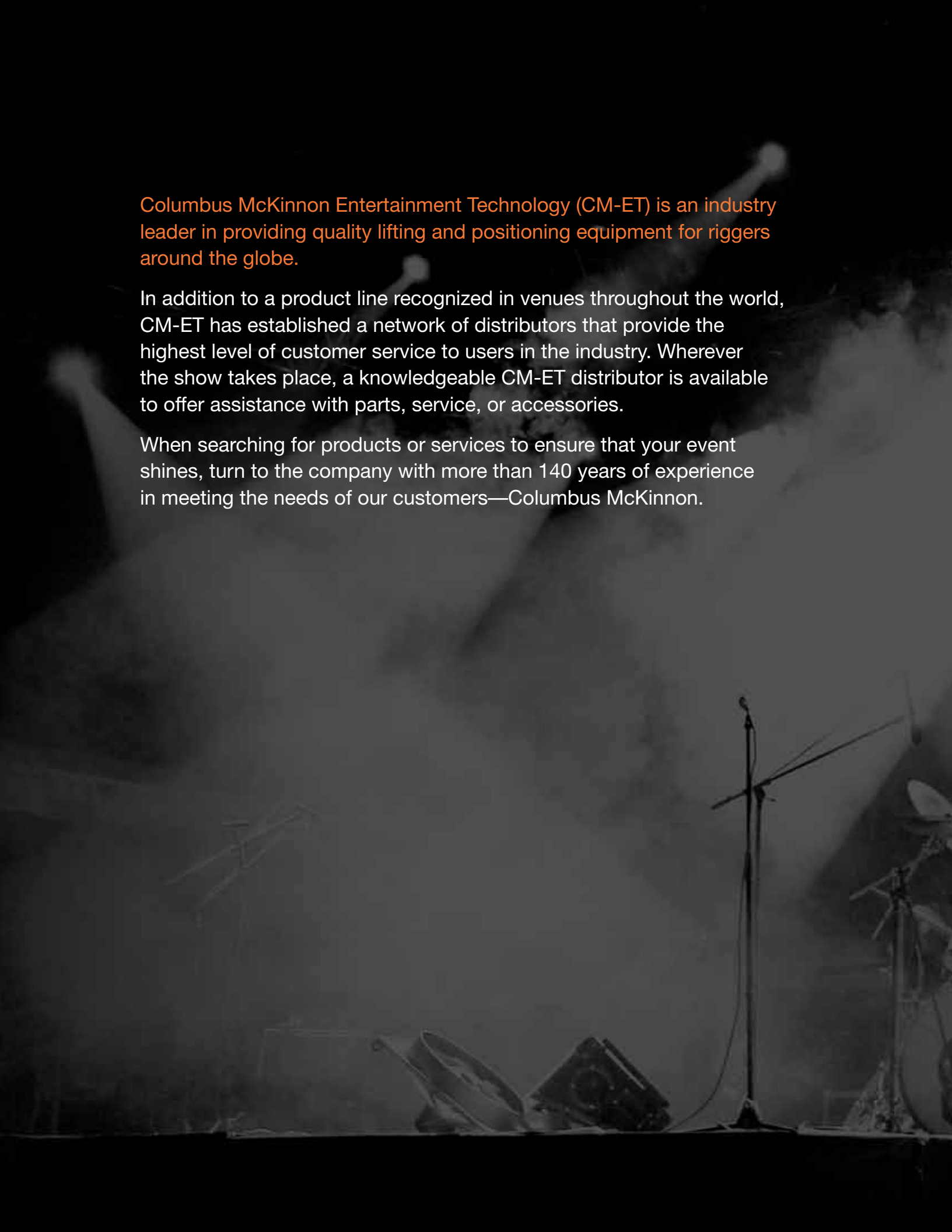

ENTERTAINMENT PRODUCT CATALOG





Columbus McKinnon Entertainment Technology (CM-ET) is an industry leader in providing quality lifting and positioning equipment for riggers around the globe.

In addition to a product line recognized in venues throughout the world, CM-ET has established a network of distributors that provide the highest level of customer service to users in the industry. Wherever the show takes place, a knowledgeable CM-ET distributor is available to offer assistance with parts, service, or accessories.

When searching for products or services to ensure that your event shines, turn to the company with more than 140 years of experience in meeting the needs of our customers—Columbus McKinnon.

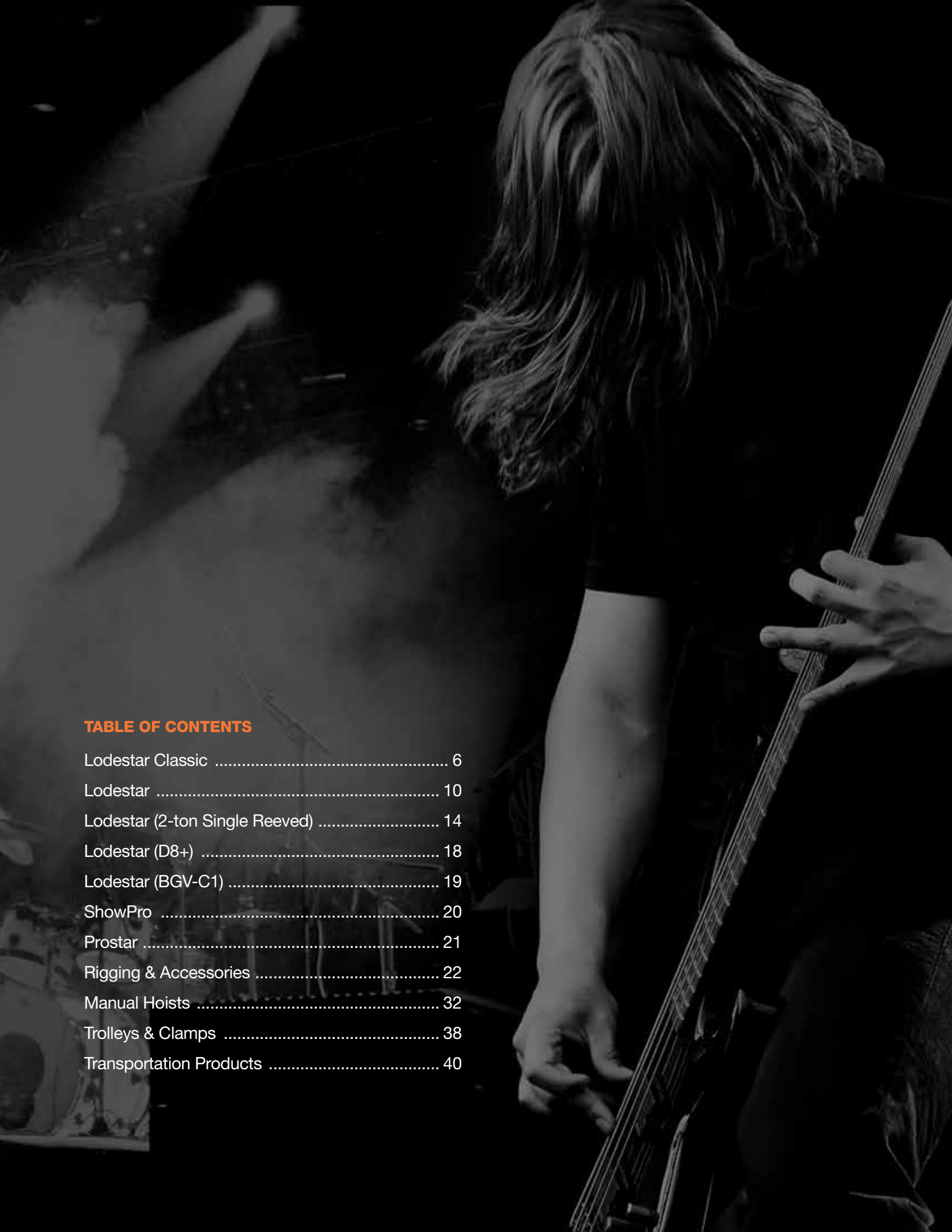

TABLE OF CONTENTS

Lodestar Classic	6
Lodestar	10
Lodestar (2-ton Single Reeved)	14
Lodestar (D8+)	18
Lodestar (BGV-C1)	19
ShowPro	20
Prostar	21
Rigging & Accessories	22
Manual Hoists	32
Trolleys & Clamps	38
Transportation Products	40



GLOSSARY

ANSI

Refers to American National Standards Institute. Specifications published by ANSI, 1430 Broadway, New York, NY 10018; (212) 642-4900.

ASME

The American Society of Mechanical Engineers, Three Park Avenue, New York, NY 10016-5990; (212) 591-7722.

ASTM

Refers to American Society of Testing and Materials. Specifications published by ASTM, 100 Barr Harbor Dr., West Conshohocken, PA 19428; (610) 832-9707.

CVSA

Commercial Vehicle Safety Alliance, 1620 Eye St. N.W., Washington, DC 20006; (202) 775-8658.

DOT

Department of Transportation 7th & D Streets S.W. Washington, D.C. 20590; (800) 832-5660

NACM

Refers to National Association of Chain Manufacturers. Specifications published by NACM, P.O. Box 3143, York, PA 17402-0143; (717) 840-1304.

OSHA

Occupational Safety & Health Administration, U.S. Department of Labor.

PLASA

PLASA is the lead international membership body for those who supply technologies and services to the event, entertainment and installation industries. PLASA North American Office: 630 Ninth Avenue, Suite 609, New York, NY 10036; (212) 244-1505

WORKING LOAD LIMIT

The working load limit of a chain is the maximum load in pounds that should ever be applied to a chain, even when the chain is new and the load is applied in direct tension to a straight length of chain.

GENERAL INFORMATION

Columbus McKinnon Corporation assumes no responsibility for the misuse or misapplication of any of its products. Products are provided with the express understanding that the purchaser and/or user are thoroughly familiar with the correct application and proper use of such products in rigging. Warnings and definitions are provided as an aid to the user in understanding the correct application and for proper use of the product.

IMPORTANT

The use of all mechanical equipment presents the possibility of personal injury or property damage if the equipment is not properly installed, operated or maintained. Before using CM chain, accessories, load binders, lifting clamps, or farm hardware, users should become thoroughly familiar with applicable installation, operation and maintenance requirements.

Observing these general precautions will also help to protect both operators and materials:

- Inspect equipment before use. Do not use chains, hooks, shackles, links, clips or other equipment components that are bent, elongated, gouged, nicked, excessively worn or damaged. Make certain that nuts, bolts, pins and other fasteners are tightened and secured. Make sure clamps are functional and will grip the load.
- Do not exceed the working load limit of equipment. Refer to catalog for specific working load limit data.
- Center load in hooks, shackles, rings and other such equipment components. Use spacers on bolts and pins as necessary to maintain center loading.
- Do not apply load to hook latches; latches are to retain slack slings and chains only.
- Avoid sudden jerks when applying the load. Rapid load application can produce overloading.
- Free all twists, knots and kinks. Apply load in a straight line fashion.
- Use only alloy chain and attachments (grade 80) for overhead lifting.
- Use clamps and lifting equipment only if authorized and properly trained.

NOTE:

Columbus McKinnon Corporation assumes no responsibility for the misuse or misapplication of any of its products. Products are provided with the express understanding that the purchaser and/or user are thoroughly familiar with the correct application and proper use. Warnings and definitions are provided as an aid to the user in understanding correct application and proper use. The manufacturer does not accept any liability for damages which result from the product being used in excess of the working load limit or from abuse.

CM REPAIR/REPLACEMENT GUARANTEE:

Columbus McKinnon Corporation, Amherst, N.Y., guarantees each new chain and forged product of its manufacture under normal use and service to be free from defects in material and workmanship. Our obligation, under this guarantee is limited to making good at our factory this product or any portion thereof, which within one year from this date shall have been returned to us and which on our examination shall disclose such defects. This guarantee shall be null and void if any repairs, annealing, plating, or heat treatment of chain or forged products has been made at any plant other than authorized by Columbus McKinnon Corporation.

This guarantee is expressly in lieu of all other warranties expressed or implied and of all other obligations or liabilities on our part, and we neither assume nor authorize any other person to assume for us any liability in connection with the sale or use of chain and forged products.

To order, call your local distributor or contact Columbus McKinnon directly at **1-800-888-0985** or email cmertainment@cmworks.com to locate your nearest distributor, master part depot or chain repair stations.

LODESTAR® CLASSIC

ELECTRIC CHAIN MOTOR

CAPACITIES

1/8 to 2 Ton

LIFT

60 feet standard (other lifts available)

SPEEDS

5 to 100 feet/minute

VOLTAGES

1-phase & 3-phase available

The legendary CM-ET Classic Lodestar electric chain motor is back for a command performance. Leading the entertainment industry for more than three decades, this workhorse offers best-in-class performance, safety and reliability. The Classic Lodestar is universally trusted by rigging professionals around the world and is ideal for touring concerts and productions both indoors and out.

BENEFITS & FEATURES

LOW VOLTAGE CONTROL

110 volt for long cable runs without voltage drop. 24 and 48 volt optional. Single-phase and three-phase also available.

IP66 RATING

An Ingress Protection (IP) Rating of 66 indicates that the Lodestar Classic offers protection from dust and high-pressure water – making this unit ideal for use in outdoor environments.

- **HIGH-PERFORMANCE COMPOSITE CORD GRIPS**
Prevent water from entering the motor body at the pendant and power cord points of entry.
- **CONTINUOUS GASKETS**
Create a waterproof seal between the gearbox assembly and the back frame and motor covers.
- **O-RINGS ON LIFT WHEEL BEARING**
Prevent water from entering the motor body through the lift wheel opening.

LONG SERVICE LIFE

- Standard AC brake is designed for a long service life.
- Lifetime grease-lubricated gear box ensures better wear and smooth operation. Heavy-duty-rated motors.
- Standard external chain guide helps extend chain life.

DUTY CYCLE

H-4 duty rated for heavy-duty applications. 2M+ FEM class. 50% duty cycle or 300 on/off per hour.

OVERLOAD PROTECTOR

Helps prevent lifting of dangerous overloads.

OVER-TRAVEL PREVENTION

Adjustable limit switch prevents load from over-travel in both up and down directions.

LIGHTWEIGHT, CAST-ALUMINUM HOUSING

Durable and strong cast-aluminum housing is black powder coated for low visibility.

METRIC RATED

ROAD READY

Easy to stow and travel.

LIFETIME WARRANTY

The industry's best warranty against manufacturing and material defects.



OPTIONAL FEATURES

SINGLE OR DOUBLE DC BRAKE

Field Installation Kit available for single or double DC brake. The double option features two independent acting DC brakes for redundant braking.

DOUBLE LIMIT SWITCH

Adjustable screw limit switch that automatically stops the hook at any predetermined point when either hoisting or lifting.

VARIABLE SPEED UNITS AVAILABLE (VFD)

Varistar or variable speed versions available. Please contact your CM-ET sales representative for details.

CM ALLOY LATCHLOK® HOOKS

Latchlok® hooks combine innovative design and solid alloy steel. I-beam construction offers more reliable performance than any other hook on the market.

ENCODERS

Available for positioning incremental and absolute.

EASY-TO-MOUNT, CLOTH-TYPE CHAIN BAGS

DIRECT CONTROL UNIT

Featuring a single cable, a unit can be used as part of a system with multiple units with a single control. Lodestar is compatible with most direct control motor controllers.

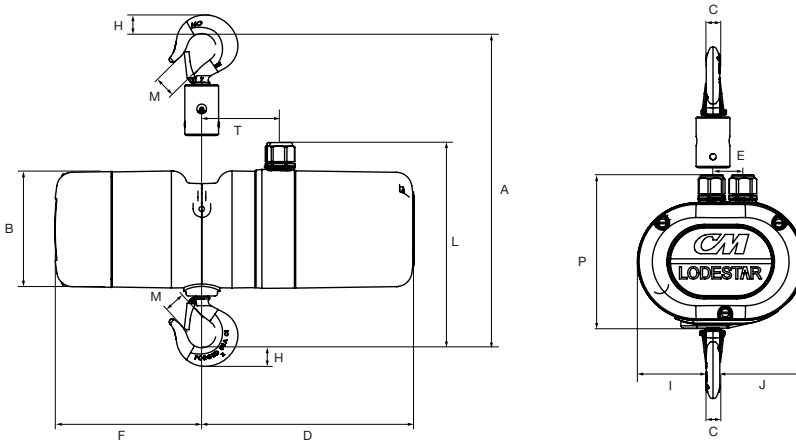

DIMENSIONS

Model	Dimensions (in.)												
	A	B	C	D	E	F	H	I	J	L	M	P	T
B, C, F	16-5/16	6-1/16	3/4	11	1-5/8	7-5/8	1	3-15/16	4-3/4	10-5/8	1-1/8	7-15/16	4-1/16
J, JJ, L, LL	18-13/16	7-5/8	7/8	9-1/2	2-7/16	10-3/4	1-1/8	5-3/8	7-3/16	12-1/4	1-1/4	9-3/16	5-3/8
R, RR	25-13/16	7-5/8	1-1/8	9-1/2	2-7/16	10-11/16	1-1/2	6-1/2	6-1/8	12-7/8	1-1/2	9-1/8	5-5/17

SPECIFICATIONS

Model	Maximum Capacity		Hoist Lifting Speed				Less Chain		10 Foot Lift		60 Foot Lift	
			60hz / FPM	60hz / MPM	50hz / FPM	50hz / MPM	Product Code		Product Code		Product Code	
	Tons	kg					115V	230/460V	115V	230/460V	115V	230/460V
B	1/4	250	16	4.9	13.3	4.1	3140	3181	3140CF	3181CF	3140CF	3181CF
C	1/4	250	32	9.8	26.7	8.1	3200	3182	3200CF	3182CF	3200CF	3182CF
F	1/2	500	16	4.9	13.3	4.1	2867	3183	2867CF	3183CF	2867CF	3183CF
J	1/2	500	32	9.8	26.7	8.1	3394	3184	3394CF	3184CF	3394CF	3184CF
JJ	1/2	500	64	19.5	53.3	16.3	—	4275	—	4275CF	—	4275CF
L	1	1000	16	4.9	13.3	4.1	3609	3185	3609CF	3185CF	3609CF	3185CF
LL	1	1000	32	9.8	26.7	8.1	—	3187	—	3187CF	—	3187CF
R	2	2000	8	2.4	6.7	2	4238	3186	4238CF	3186CF	4238CF	3186CF
RR	2	2000	16	4.9	13.3	4.1	—	3188	—	3188CF	—	3188CF

LODESTAR® CLASSIC

ELECTRIC CHAIN MOTOR

KEY COMPONENTS

1. 4-POCKET LIFT WHEEL

Lift wheel with improved water and dust sealing features for IP66 level protection.

2. ADJUSTABLE LIMIT SWITCH

Easy-to-adjust screw limit switch automatically stops the hook at any predetermined point when either lifting or lowering, preventing overtravel. (Low-voltage unit only)

3. PROVEN BRAKE DESIGN

Heavy-duty AC electromechanical brake has been field tested in more than one million Lodestar hoists worldwide. Optional DC brake and double DC brake are also available.

4. EASY-ACCESS CONTROL PANEL

Finger-safe wiring and plug-and-play connectors on the control panel allow for quick voltage change from 208/230 to 460. Prevents improper voltage connections that may cause hoist damage. Easy access to terminal strips and simple fuse installation. (Low-voltage units only)

5. ZINC-PLATED LOAD CHAIN

Designed and manufactured in the USA by Columbus McKinnon, our zinc-plated Star Grade load chain protects against corrosion. Optional black finish available.

6. EXTERNAL CHAIN GUIDE

The standard external chain guide provides efficient chain management for longer chain life. It also protects the hoist from damage caused by cross linked chain, as well as damage to the internal guides and hoist frame. The guide is easily replaced and can be retrofitted to older units in the field.



1 LIFT WHEEL

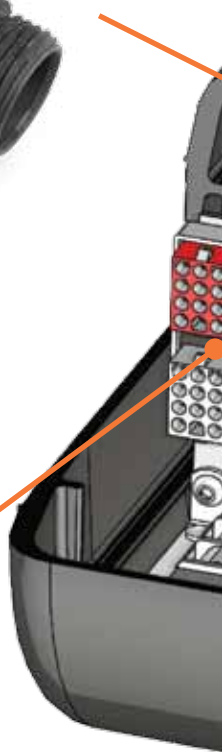

4 CONTROL PANEL



5 LOAD CHAIN



2 LIMIT SWITCH



3 BRAKE

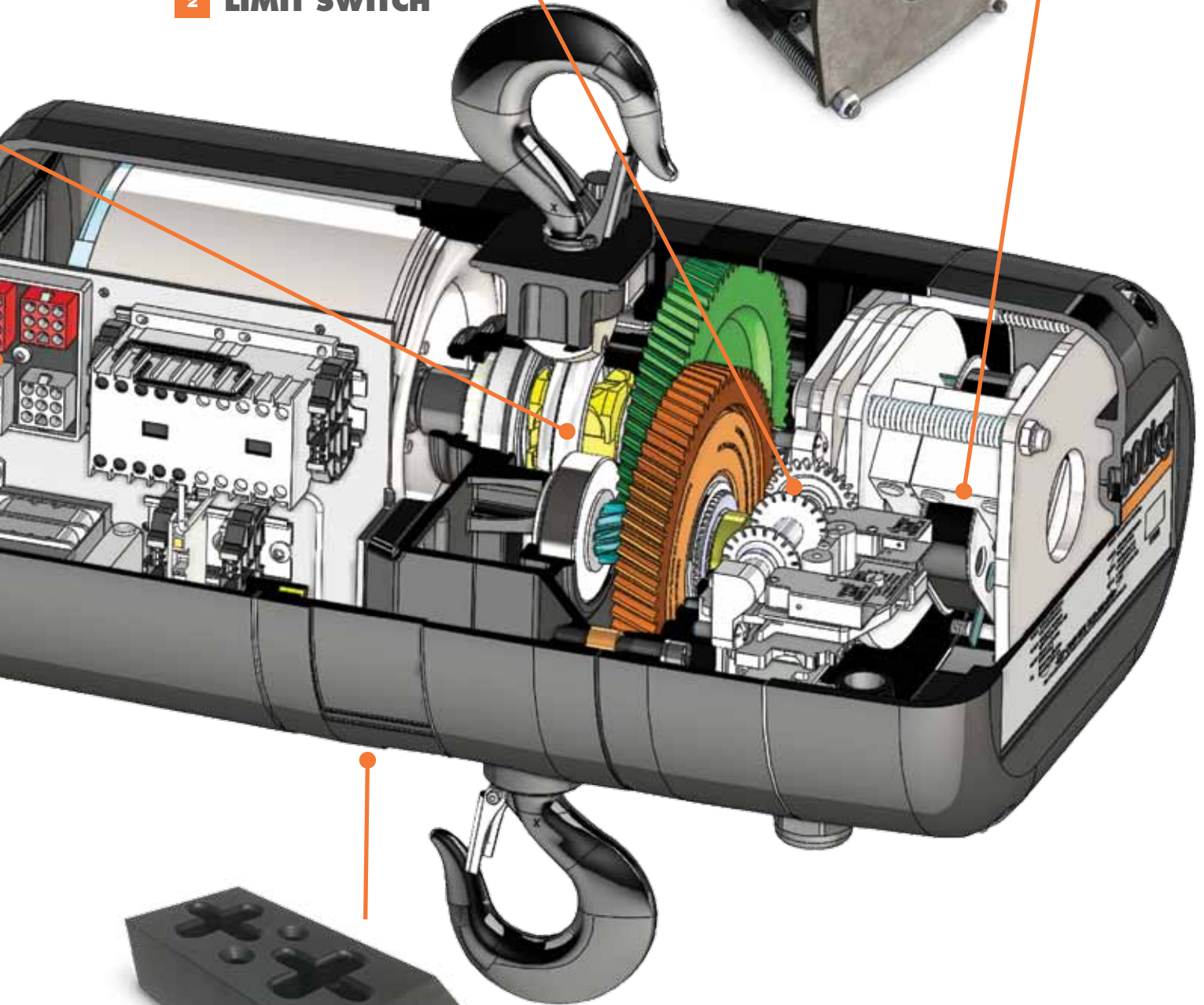

6 EXTERNAL CHAIN GUIDE

LODESTAR®

ELECTRIC CHAIN MOTOR

CAPACITIES

1/8 to 2 Ton

LIFT

60 feet standard (other lifts available)

SPEEDS

5 to 100 feet/minute

VOLTAGES

1-phase & 3-phase available

From world touring rock concerts and Broadway musicals to Las Vegas shows and sporting events, the CM Lodestar is the trusted industry workhorse.

BENEFITS & FEATURES

IP66 RATING

An Ingress Protection (IP) Rating of 66 indicates that the Lodestar offers protection from dust and high-pressure water – making this unit ideal for use in outdoor environments.

- **HIGH-PERFORMANCE COMPOSITE CORD GRIPS**
Prevent water from entering the motor body at the pendant and power cord points of entry.
- **CONTINUOUS GASKETS**
Create a waterproof seal between the gearbox assembly and the back frame and motor covers.
- **O-RINGS ON LIFT WHEEL BEARING**
Prevent water from entering the motor body through the lift wheel opening.

5 POCKET LIFTWHEEL

Improved chain wear & smooth lifting.

CLUTCH OUTSIDE GEAR TRAIN

Meets international standards.

PRECISION HELICAL GEARING

For quieter operation.

REDESIGNED CONTROL PANEL

For easier access.

HEAVY DUTY DC BRAKE

Designed for a long service life, the brake location allows for quick access & easy inspection.

LOW VOLTAGE CONTROL

110 Volt for long cable runs without voltage drop. 24 & 48 Volt optional. (Low Voltage Unit Only)

DURABLE & LIGHTWEIGHT HOUSING

Cast aluminum. Black powder coated finish for low visibility.

GEARING

Helical design for long wear life and smooth operation.

LOAD CHAIN

Designed and manufactured by Columbus McKinnon. Zinc plated to protect against corrosion. Optional black finish available.

DUTY CYCLE

H-4 duty rated for heavy duty application. 2M+ FEM class. 50% Duty Cycle or 300 on/off per hour.

ELECTRICAL

Finger safe wiring meets all electrical codes. Quick change plugs allow for voltages 208 through 460. Prevents improper voltage connections which can cause hoist damage. (Low Voltage Unit Only)

ADJUSTABLE LIMIT SWITCH

Adjustable screw limit switch that will automatically stop the hook at any predetermined point when either lifting or lowering, preventing overtravel. (Low Voltage Unit Only)

OVERLOAD PROTECTOR

Designed to prevent lifting of excessive overloads. Helps prevent lifting of dangerous overloads.

METRIC RATED MEETS REQUIREMENTS

Meets or exceeds world standards.

ROAD READY

Easy to stow and travel.

LIFETIME WARRANTY

The industry's best.



OPTIONAL FEATURES

DOUBLE DC BRAKE

Two independent acting DC brakes for redundant braking. Field installation kit available.

AC ELECTRIC BRAKE

DOUBLE LIMIT SWITCH

Adjustable screw limit switch that will automatically stop the hook at any predetermined point when either hoisting or lifting.

ENCODERS

Available for positioning incremental and absolute.

VARIABLE SPEED UNITS AVAILABLE (VFD)

Varistar or variable speed versions available, please contact your CM-ET sales representative for details.

CM ALLOY LATCHLOK® HOOKS

Latchlok® hooks combine innovative design and solid allow steel. I-beam construction offers more reliable performance than any other hook on the market.

- One-hand operation and recessed push-button thumb release for smooth and dependable opening.
- Hook remains locked until released by the operator, even if chain goes slack.
- Sturdy forged heat treated I-beam construction for strong, yet lightweight hooks.
- Lifetime warranty.
- Made in U.S.A.

CHAIN BAGS

Cloth type bags easy-to-mount.

DIRECT CONTROL UNITS

The CM Lodestar is available as a Direct Control Unit. Featuring a single cable, this Direct Control Unit can be used as part of a system with multiple units with a single control. The Lodestar is compatible with most Direct Control Motor Controllers.

DIMENSIONS

Drawing Legend	Dimensions (in.)		
	Models B, C, F	Models J, JJ, L, LL	Models R, RR
A	16.20	18.5625	24.125
B	6.08	7.62	7.62
C	.67	.875	1.125
D	11.80	10.03	10.03
F	8.94	13.01	13.01
H	1	1.1875	1.5
I	4.46	6.93	5.57
J	4.22	5.69	7.05
M	1	1.125	1.3125
P	6.62	8.22	8.22

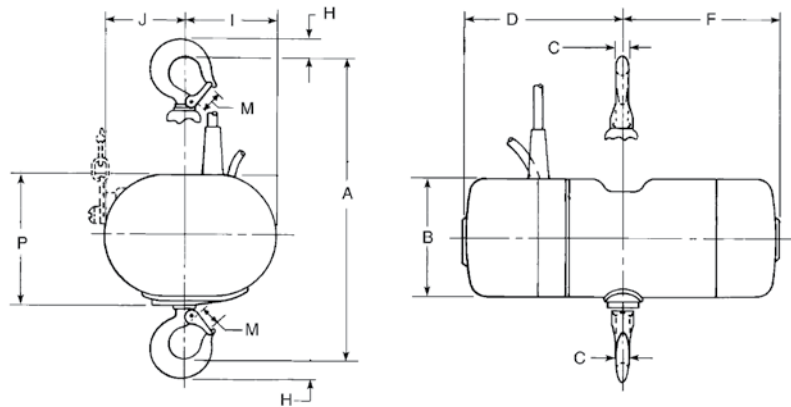

SPECIFICATIONS

Model	Rated Load (Ton) *	Product Code		Chain Size Used (in.)	Lifting Speed (FPM)	Motor HP	Full Load Amps		Work Rating		Reeving	Lift (Feet) ***
		115-1-60	230/460-3-60				115-1-60	230/460-3-60	HMI	FEM		
B	1/4	3140NH	3169NH	1/4	16	1/4	5.3	1.8/1.1	H4	2M+	1	60
C	1/4	3200NH	3201NH	1/4	32	1/2	7.9	2.2/1.3	H4	2M+	1	60
F	1/2	2867NH	2868NH	1/4	16	1/2	7.9	2.2/1.3	H4	2M+	1	60
J	1/2	3394NH	3482NH	5/16	32	1	11.9	3.7/2.2	H4	2M+	1	60
JJ	1/2	n/a	4271NH	5/16	64	2	n/a	7.9/5.0	H4	2M+	1	60
L	1	3609NH	3610NH	5/16	16	1	11.9	3.7/2.2	H4	2M+	1	60
LL	1	n/a	4273NH	5/16	32	2	n/a	7.9/5.0	H4	2M+	1	60
R	2	4238NH	4239NH	5/16	8	1	11.9	3.7/2.2	H4	2M+	2	60
RR	2	n/a	4272NH	5/16	16	2	n/a	7.9/5.0	H4	2M+	2	60

* Metric Tons

*** Lifts other than 60 ft. available (Standard Units shipped less chain unless specified)

Consult factory for additional speeds and capacities

2-TON, SINGLE REEVED MODELS (Next page)

LODESTAR[®]

ELECTRIC CHAIN MOTOR

KEY COMPONENTS

1. LIFT WHEEL

5 Pocket Liftwheel increases chain and liftwheel engagement while providing smoother lifting, less vibration and reduced chain wear when properly maintained.

2. LIMIT SWITCH

Adjustable screw limit switch that will automatically stop the hook at any predetermined point when either hoisting or lifting.

3. BRAKE

Heavy Duty DC Brake is standard. AC Brake and Double DC Brake are also available.

4. CONTROL PANEL

Provides easy access to controls, plug and play connectors allow for quick voltage change for dual voltage motors. Fuses located on terminal strip (optional).

5. CLUTCH

Designed to prevent lifting of excessive overloads. Located outside the gear box. Adjustable and easy to access.

6. LOAD CHAIN

Sizes available from 1/4 in. to 5/16 in. Meets or exceeds many national and international standards. Zinc plated supplied as standard. Black phosphate finish available. 100% proof tested.

7. INTERNAL CHAIN GUIDE

Stamped Steel guide coated for corrosion resistance and quiet operation, while keeping the load chain and liftwheel aligned.



1 LIFT WHEEL

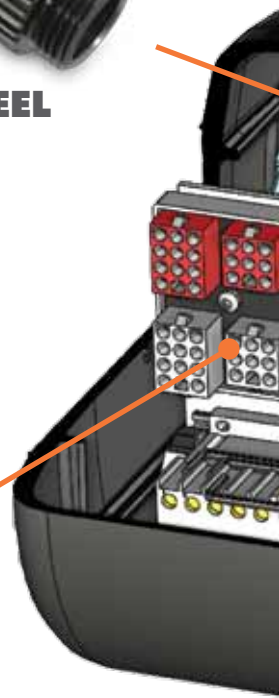

4 CONTROL PANEL



5 CLUTCH



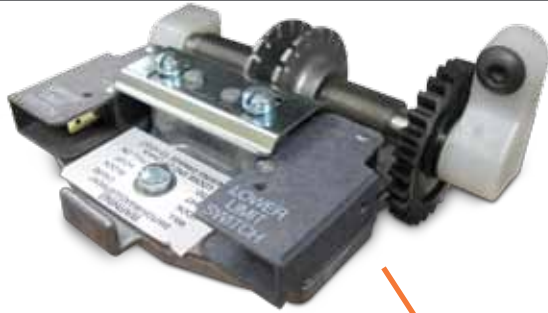

2 LIMIT SWITCH



3 BRAKE

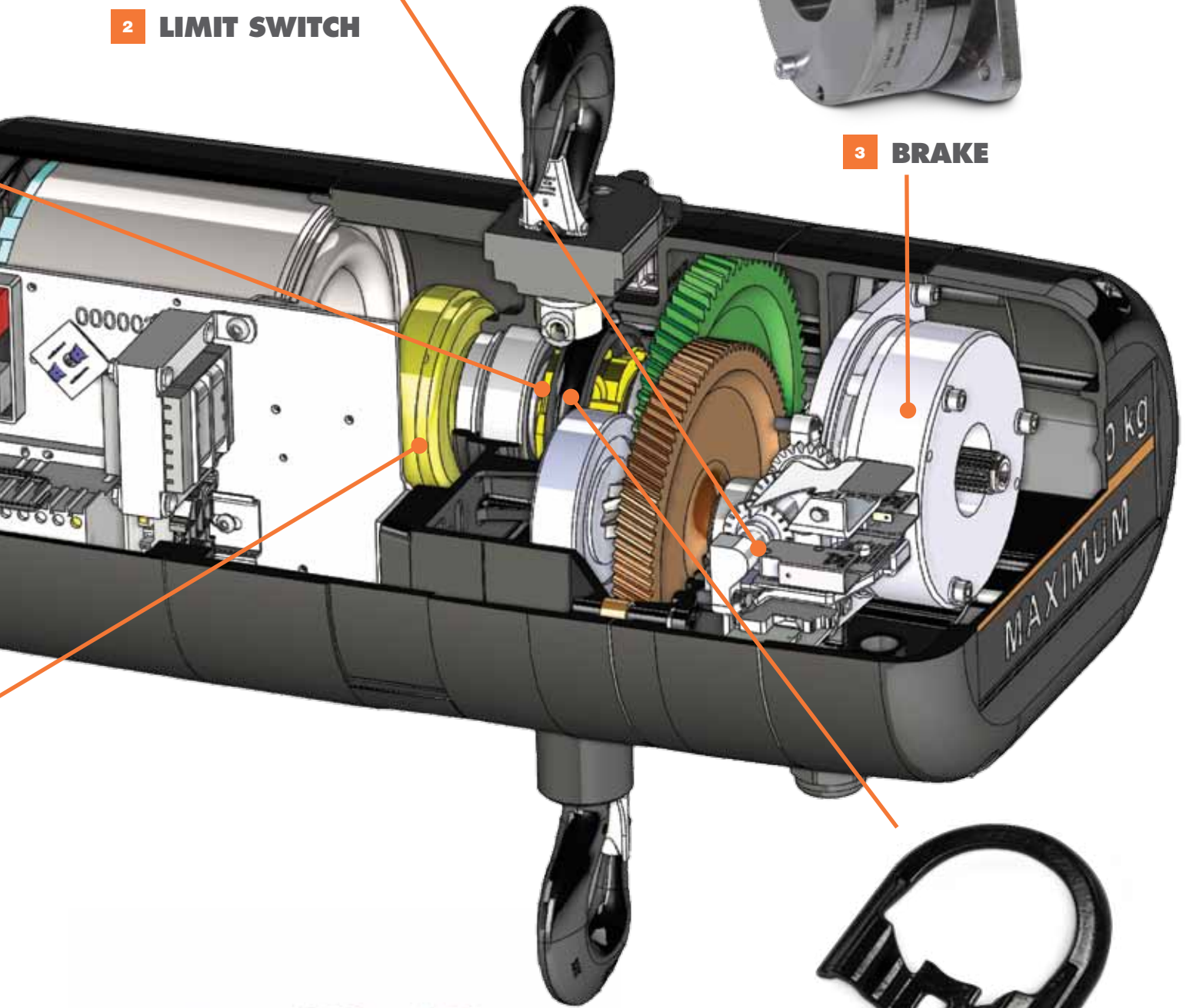

6 LOAD CHAIN



7 INTERNAL CHAIN GUIDE

LODESTAR®

ELECTRIC CHAIN MOTOR

2-TON SINGLE-REEVED

The CM® entertainment Lodestar® is now available as an economical 2-ton, single-reeved unit that's ideal for a variety of lifting applications. And, because it's a single-reeved unit, overall weight is decreased making it easier to transport and rig compared to a traditional double-reeved unit.

BENEFITS & FEATURES

IP 66 RATING

An Ingress Protection (IP) Rating of 66 indicates that the Lodestar offers protection from dust and high-pressure water – making this unit ideal for use in outdoor environments.

- **HIGH-PERFORMANCE COMPOSITE CORD GRIPS**
Prevent water from entering the motor body at the pendant and power cord points of entry.
- **CONTINUOUS GASKETS**
Create a waterproof seal between the gearbox assembly and the back frame and motor covers.
- **O-RINGS ON LIFT WHEEL BEARING**
Prevent water from entering the motor body through the lift wheel opening.

EASY TO TRANSPORT & RIG

With less chain than double-reeved units, the 2-ton, single-reeved Lodestar is lighter, making it easier to transport and rig.

ZINC PLATED LOAD CHAIN

Designed and manufactured in the USA by Columbus McKinnon, our 10 millimeter, zinc-plated Star Grade load chain protects against corrosion.

IMPROVED CHAIN LIFE

5-pocket lift wheel provides better chain and lift wheel engagement for smoother lifting and reduced vibration, equating to less wear and a longer chain life.

LESS MAINTENANCE & EASIER INSPECTION

- Brake location allows for quick access and easy inspection.
- Lifetime grease-lubricated gear box means no oil change is required.
- Clutch located outside the gear box allows for easy access, which eliminates the need for complete disassembly and reduces downtime.

IMPROVED SERVICEABILITY

Easy access to the clutch, motor, electrical control panel and brake assembly.

METRIC RATED

EASY-ACCESS CONTROL PANEL

Finger-safe wiring and plug-and-play connectors on the control panel allow for quick voltage change, easy access to terminal strips and simple fuse installation.

LONGER SERVICE LIFE

- Heavy-duty DC brake is designed for a long service life.
- Lifetime grease-lubricated gear box and helical gearing ensures better wear and smooth operation. Heavy-duty-rated motors.

IMPROVED LOAD SAFETY

Clutch is located outside the load path, preventing slipping of the load in an overload condition when the brake is not powered.

ADJUSTABLE LIMIT SWITCH

Easy-to-adjust screw limit switch automatically stops the hook at any predetermined point when either lifting or lowering, preventing overtravel.

OVERLOAD PROTECTOR

Helps prevent lifting of dangerous overloads.

STANDARD ROTATABLE LIMIT SWITCH

Designed for quick reset of limit position.

LIFETIME WARRANTY

The industry's best warranty against manufacturing and material defects.

SWIVEL OR RIGID HOOK SUSPENSION AVAILABLE



HIGH-PERFORMANCE COMPOSITE CORD GRIPS



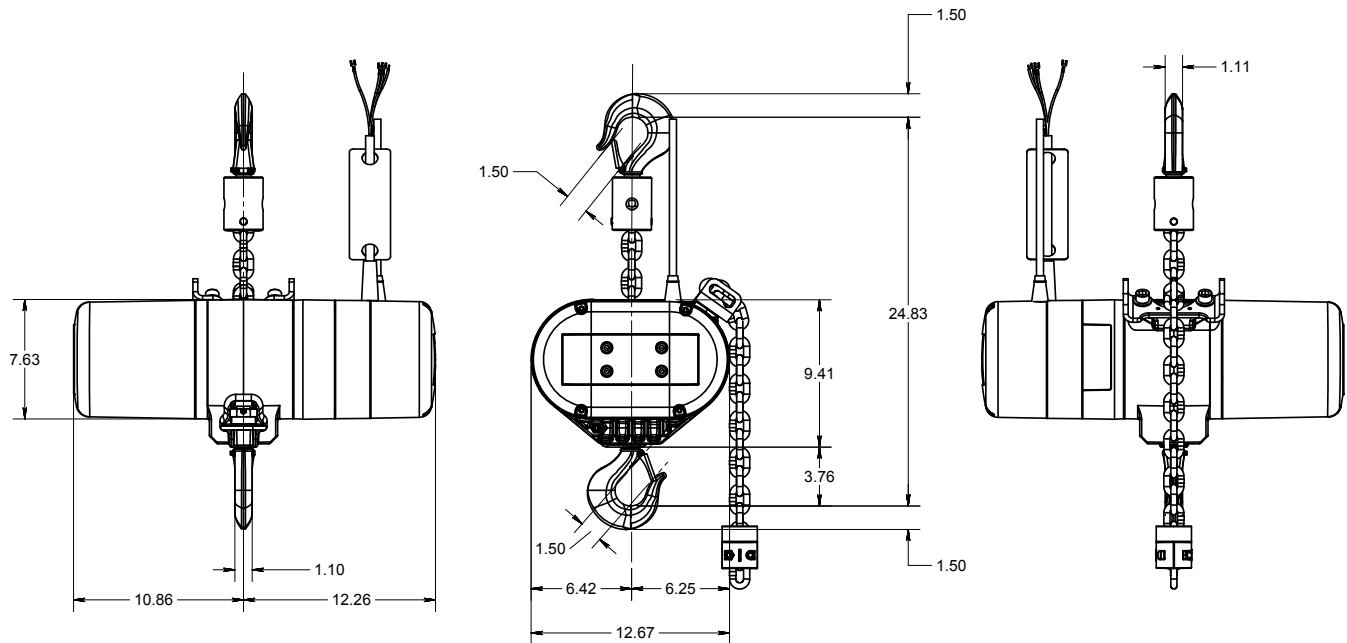

Dimensions (in inches) are RRS model CM-ET Lodestar 2 Ton Single Reeved with Swivel Latch Type Hook Suspension.

OPTIONAL FEATURES

DOUBLE DC BRAKE

Two independent acting DC brakes for redundant braking. Field installation kit available.

DOUBLE LIMIT SWITCH

Adjustable screw limit switch that will automatically stop the hook at any predetermined point when either hoisting or lifting.

ENCODERS

Available for positioning incremental and absolute.

VARIABLE SPEED UNITS AVAILABLE (VFD)

Varistar or variable speed versions available, please contact your CM-ET sales representative for details.

CM ALLOY LATCHLOK® HOOKS

Latchlok® hooks combine innovative design and solid alloy steel. I-beam construction offers more reliable performance than any other hook on the market.

- One-hand operation and recessed push-button thumb release for smooth and dependable opening.
- Hook remains locked until released by the operator, even if chain goes slack.
- Sturdy forged heat treated I-beam construction for strong, yet lightweight hooks.
- Lifetime warranty.
- Made in U.S.A.

DIRECT CONTROL UNITS

The CM Lodestar is available as a Direct Control Unit. Featuring a single cable, this Direct Control Unit can be used as part of a system with multiple units with a single control. The Lodestar is compatible with most Direct Control Motor Controllers.

D8+

Meets all Standard VPLT SR 2.0/SQP2 requirements.

BGV-C1

Meets all standard C1 and DIN 56950 requirements.



LODESTAR[®]

ELECTRIC CHAIN MOTOR

2-TON SINGLE-REEVED KEY COMPONENTS

1. LIFT WHEEL

5 Pocket Liftwheel increases chain and liftwheel engagement while providing smoother lifting, less vibration and reduced chain wear when properly maintained.

2. LIMIT SWITCH

Adjustable screw limit switch that will automatically stop the hook at any predetermined point when either hoisting or lifting.

3. BRAKE

Heavy Duty DC Brake is standard. AC Brake and Double DC Brake are also available.

4. CONTROL PANEL

Provides easy access to controls, plug and play connectors allow for quick voltage change for dual voltage motors. Fuses located on terminal strip (optional).

5. CLUTCH

Designed to prevent lifting of excessive overloads. Located outside the gear box. Adjustable and easy to access.

6. LOAD CHAIN

Sizes available from 1/4 in. to 5/16 in. Meets or exceeds many national and international standards. Zinc plated supplied as standard. Black phosphate finish available. 100% proof tested.

7. INTERNAL CHAIN GUIDE

Stamped Steel guide coated for corrosion resistance and quiet operation, while keeping the load chain and liftwheel aligned.



1 LIFT WHEEL

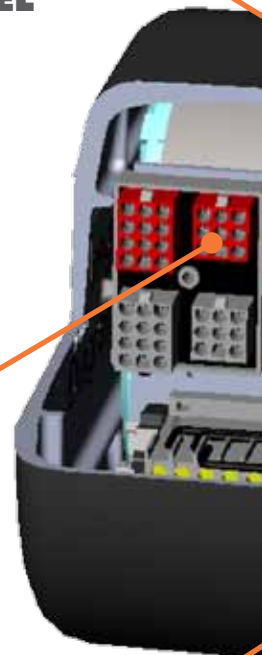

4 CONTROL PANEL



5 CLUTCH



6 LOAD CHAIN



2 LIMIT SWITCH



3 BRAKE

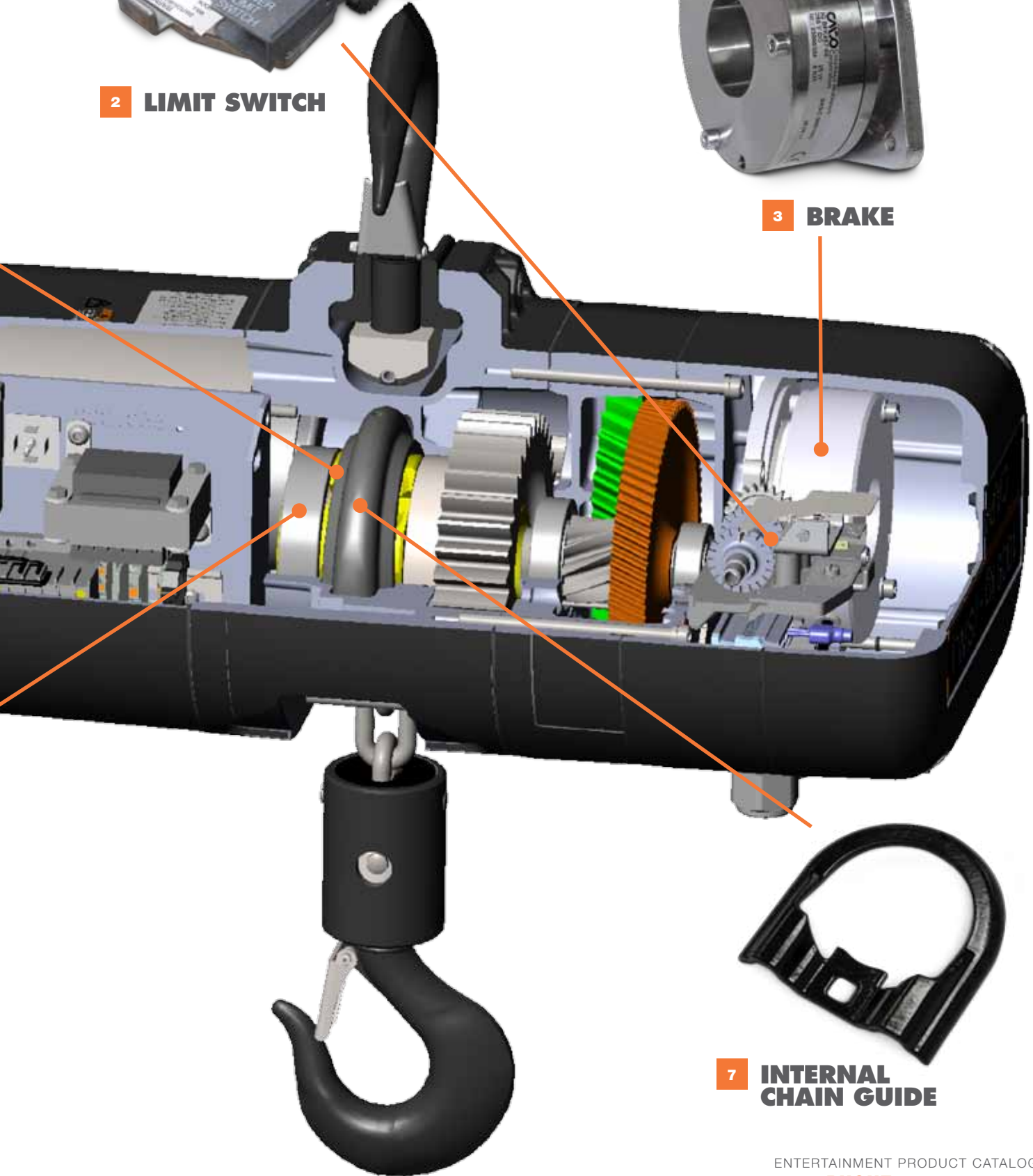

7 INTERNAL CHAIN GUIDE

LODESTAR® D8+

ELECTRIC CHAIN MOTOR

CAPACITIES

70 to 1500 KG LIFT

LIFT

60 feet standard

SPEEDS

5 to 64 feet /min

VOLTAGES

3-phase available

The Lodestar D8+ meets all Standard SR2.0 requirements. It's clutch, outside the load path, acts as a precise overload device; and design factor is 10:1 with a double brake installed. The Lodestar D8+ is in accordance with the VPLT Code of Practice.

BENEFITS & FEATURES
10:1 MECHANICAL DESIGN FACTOR
ELECTRO-MECHANICAL DOUBLE BRAKES
5 POCKET LIFT WHEEL

For quiet & smooth operation.

68 DB OPERATIONAL NOISE

A result of the Double Brake System.

GEARING

Precision machined gears heat treated for strength and durability.

INTERNAL CHAIN GUIDE

PVC black coated for quieter operation.

LOW VOLTAGE CONTROL

110 Volt for long cable runs without voltage drop. 24 & 48 Volt optional.

DUTY CYCLE

H-4 duty rated for heavy duty application. 2M+ FEM class. 50% Duty Cycle or 300 on/off per hour.

IP54 PROTECTION CLASS
SPECIFICATIONS

Model	Product Code	Chain Size Used	Rated Load (KG)	Lifting Speed (FPM)	Motor HP	Operating Voltage	Full Load Amps	Work Rating		Reeving	Lift (Feet) ***
								HMI	FEM		
B	3181NHCF	1/4	125	16	1/4	230/460-3-60	1.8/1.1	H4	2M+	1	60
C	3182NHCF	1/4	125	32	1/2	230/460-3-60	2.2/1.3	H4	2M+	1	60
F	3205NH	1/4	250	16	1/2	230/460-3-60	2.2/1.3	H4	2M+	1	60
J	3184NHCF	5/16	250	32	1	230/460-3-60	3.7/2.2	H4	2M+	1	60
JJ	3206NH	5/16	500	64	2	230/460-3-60	7.9/5.0	H4	2M+	1	60
L	3207NH	5/16	650	16	1	230/460-3-60	3.7/2.2	H4	2M+	1	60
LL	3208NH	5/16	500	32	2	230/460-3-60	7.9/5.0	H4	2M+	1	60
R	3209NH	5/16	1300	8	1	230/460-3-60	3.7/2.2	H4	2M+	2	60
RR	3210NH	5/16	1000	16	2	230/460-3-60	7.9/5.0	H4	2M+	2	60
RT	Contact Factory	5/16	1500	5	1	230/460-3-60	3.7/2.2	H4	2M+	3	60

*** Lifts other than 60ft available (Standard Units shipped less chain unless specified)

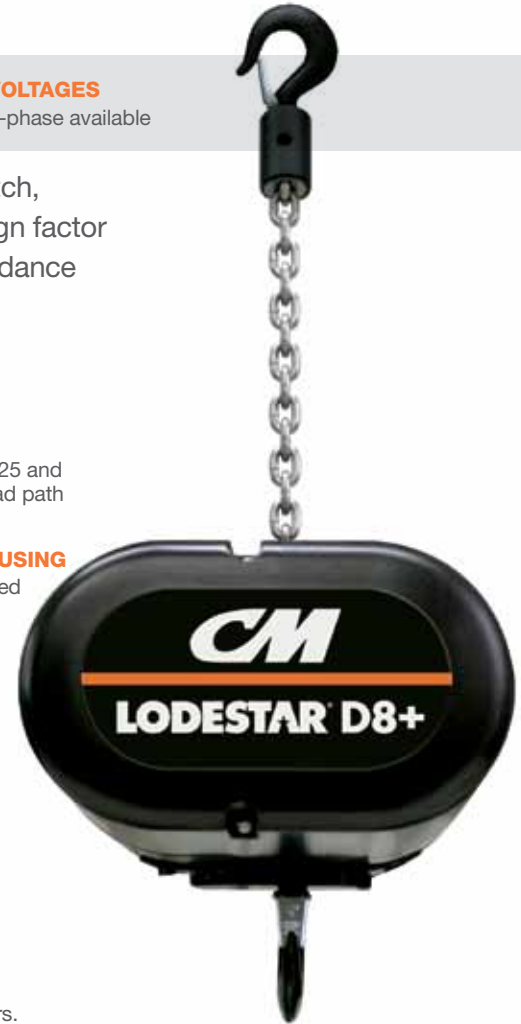

LODESTAR® BGV-C1

ELECTRIC CHAIN MOTOR

CAPACITIES
250 to 1300 KG

LIFT
60 feet standard

SPEEDS
16 to 100 feet/min

VOLTAGES
3-phase available

The Lodestar BGV-C1 Series meets the BGV-C1 German regulation for entertainment rigging. Available with fixed or variable speed, the Lodestar BGV-C1 can be adapted to reach a System Integrity Level 3 (SIL3).*

BENEFITS & FEATURES

10:1 MECHANICAL DESIGN FACTOR

We exceed current standard DIN 56950.

ELECTRO-MECHANICAL DOUBLE BRAKES

5 POCKET LIFT WHEEL

For quiet & smooth operation.

68 DB OPERATIONAL NOISE

A result of the Double Brake System.

GEARING

Precision machined gears heat treated for strength and durability.

INTERNAL CHAIN GUIDE

PVC black coated for quieter operation.

LOW VOLTAGE CONTROL

110 Volt for long cable runs without voltage drop. 24 & 48 Volt optional.

DUTY CYCLE

H-4 duty rated for heavy duty application. 2M+ FEM class. 50% Duty Cycle or 300 on/off per hour.

UNDERLOAD PROTECTION

With load cell installed.

MODULAR MULTI-PIN CONNECTOR

With multi-wire shielded cable.

4 POSITION LIMIT SWITCH

With active spring micro-switch.

BUILT-IN PLC

For safety function monitoring, Brake and Limit Switch integrity, Load Cell reading, Overload and Underload settings.

OVERLOAD PROTECTION

Rated operational range between 125 and 150/160%. Clutch is outside the load path when disconnected from power.

DURABLE & LIGHTWEIGHT HOUSING

Cast aluminum. Black powder coated finish for low visibility.

METRIC RATED LOAD CHAIN

Designed and manufactured by Columbus McKinnon. Zinc plated to protect against corrosion. Black phosphate finish optional.

THE INDUSTRY'S BEST LIFETIME WARRANTY

MEETS OR EXCEEDS WORLD STANDARDS

Meets German Regulation BGV-C1.

CHAIN STOP

Mounted on load chain to prevent overtravel.

OPTIONAL FEATURES

ENCODERS

Available for positioning incremental and absolute.

* SIL3 requires a BGV-C1 SIL3 certified controller not included.



SPECIFICATIONS

Model	Product Code	Chain Size Used	Rated Load (kg)	Lifting Speed (FPM)	Motor HP	Operating Voltage	Full Load Amps	Reeving	Protection Class	Noise Level	Lift (Feet) ***
F	Contact Factory	1/4	250	16	1/2	230/460-3-60	2.2/1.3	1	IP54	68 dB	60
J		5/16	250	32	1	230/460-3-60	3.7/2.2	1	IP54	68 dB	60
JJ		5/16	500	64	2	230/460-3-60	7.9/5.0	1	IP54	68 dB	60
L		5/16	650	16	1	230/460-3-60	3.7/2.2	1	IP54	68 dB	60
LL		5/16	500	32	2	230/460-3-60	7.9/5.0	1	IP54	68 dB	60
RR		5/16	1000	16	2	230/460-3-60	7.9/5.0	2	IP54	68 dB	60
VARISTAR		5/16	500	0 to 100	3-1/2	230/460-3-60	10.4/6.2	1	IP54	68 dB	60

*** Lifts other than 60ft available (Standard Units shipped less chain unless specified)

SHOWPRO

ELECTRIC CHAIN MOTOR

CAPACITIES

 1/2, 1 & 2 Tonne
 500, 1000 & 2000 Kgs.

LIFT

 66 feet
 20 meters

SPEEDS

 16 feet/minute at 60Hz
 4.1 meters/minute at 50Hz

The ShowPro electric chain hoist is designed to meet all basic entertainment rigging needs. Low Voltage Control and Direct Control available. Direct Control hoists offer an optional control cable fitted with IEC style connectors, 4-way hoist controller and chain bag for a complete plug and play system.

BENEFITS & FEATURES
VERSATILE

Operates on a wide range of 3-phase voltages.

LIGHTWEIGHT

Aluminum housing.

EFFICIENT

Engineered for smooth, quiet operation;

FEATURING A 5-POCKET LIFT WHEEL.

RELIABLE

OVERLOAD CLUTCH

Protects hoist, operator, structure from damaging overloads.

LIFETIME WARRANTY

Against defective materials and workmanship.

SPECIFICATIONS

Model	Capacity (Tonne)	Number of Chains	Lift (Feet)	Lifting Speed (FPM)	Motor HP	Motor Voltage/Phase/ Hertz	Amps	Motor Voltage/Phase/ Hertz	Amps	APX. Ship Wt. W/ 66 ft. Lift (lbs.)
SP1003	1/2	1	66	16	1/2	230/3/60	2	460/3/60	1	119
SP2003	1	1	66	16	1	230/3/60	3.2	460/3/60	1.6	126
SP4003	2	2	66	8	1	230/3/60	3.2	460/3/60	1.6	186

Standard operational 3-phase voltages — 208, 230, 380, 415, 460 @ 50 or 60 Hertz

DIMENSIONS

Model	Capacity		Chain Size		Housing Dimensions (in.)		
	Tonne	Kg.	in.	mm	H	W	L
SP1003	1/2	500	9/32	7.1	8 11/16	8 11/16	24 3/8
SP2003	1	1000	9/32	7.1	8 11/16	8 11/16	24 3/8
SP4003	2	2000	9/32	7.1	8 11/16	8 11/16	24 3/8

PROSTAR®

ELECTRIC CHAIN MOTOR

CAPACITIES

300 to 1000 LBS

LIFT

60 feet standard

SPEEDS

8 to 40 feet/minute

VOLTAGES

3-phase available

Lightweight, quiet and portable, the CM Prostar is designed and built for the unique rigging needs encountered at small venues. Featuring an overload device that protects the hoist, operator and structure from damaging overloads.

BENEFITS & FEATURES

DC ELECTRO-MECHANICAL BRAKES

Non-adjusting for low maintenance and quiet operation.

GEARING

Precision machined gears heat treated for strength and durability.

CHAIN GUIDE

One piece jam free for smooth operation.

HOUSING

Lightweight, cast aluminum, durable and strong black powder coated finish for low visibility.

LIFT WHEEL

CM patented 10 pocket oblique lift wheel for quiet and smooth operation.

LOW VOLTAGE CONTROL

110 Volt for long cable runs without voltage drop. 24 and 48 Volt optional.

DUTY CYCLE

H-4 duty rated, designed for heavy duty application.

OVERLOAD PROTECTION

Helps prevent lifting of dangerous overloads.

CHAIN STOP

Mounted on Load Chain prevents over-travel.

METRIC RATED

LOAD CHAIN
Designed and manufactured by Columbus McKinnon. Zinc plated to protect against corrosion. Black phosphate finish optional.

THE INDUSTRY'S BEST LIFETIME WARRANTY

MEETS OR EXCEEDS WORLD STANDARDS

OPTIONAL FEATURES

CHAIN BAG

Easy-to-Mount Cloth Type Bags.

DOUBLE BRAKE

ENCODER

UPPER SWIVEL HOOK SUSPENSION



SPECIFICATIONS

Capacity	Number of Chains	Motor HP	Lifting Speed (FPM)	Weight Less Chain (lbs.)	Weight 1 ft. of Chain (lbs.)	Full Load Amps		
						1-Phase	3-Phase	
							220v	415v
300	1	1/6	16	28	.35	3.6	1.2	.6
300	1	1/6	24	28	.35	-	1.1	.6
500	1	1/6	16	28	.35	-	1.2	.7
500	1	1/6	12	28	.35	4	-	-
600	2	1/6	8	36	.7	3.6	1.1	.6
600	2	1/6	12	36	.7	-	1.1	.6
1000	2	1/6	8	36	.7	-	1.2	.7

Drawing Legend	Reeving	
	Single	Double
A	11"	12 1/8"
B	2 15/16"	3 1/2"
C	2 7/8"	2 3/8"

Models (lbs.)	Lift Speed (FPM)	Operating Voltage			
		1-Phase		3-Phase	
300	16	115-1-50/60	220-1-50/60	220-3-50/60	415-3-50/60
300	24	-	-	220-3-50/60	415-3-50/60
300	40	-	-	220-3-50/60	415-3-50/60
500	12	115-1-50/60	220-1-50/60	-	-
500	16	-	-	220-3-50/60	415-3-50/60
500	20	-	-	220-3-50/60	415-3-50/60
600	8	115-1-50/60	220-1-50/60	-	-
600	12	-	-	220-3-50/60	415-3-50/60
1000	6	115-1-50/60	220-1-50/60	-	-
1000	8	-	-	220-3-50/60	415-3-50/60
1000	12	-	-	220-3-50/60	415-3-50/60

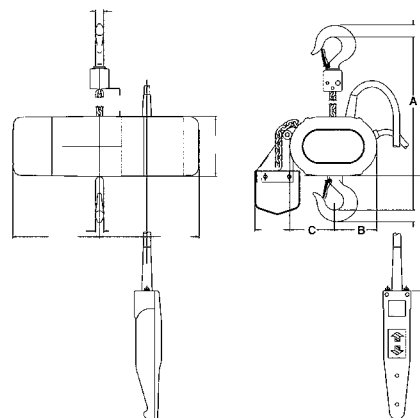

SHACKLE USE, CARE & INSPECTION

- Improper use or care of shackles can result in bodily injury or property damage. Always observe the following guidelines when using shackles.
- Do not exceed the working load limit.
- Do not shock load.
- Do not side load – center line of load must coincide with the center line of the shackle. Shackles are designed and rated for in-line applied tension. You can attach multiple slings in the body of a shackle without reducing the capacity provided that the shackle is symmetrically loaded and the included angle does not exceed 120 degrees. (See Side Loading and Symmetrical Loading sections).
- Do not replace pin or bolt with other than original equipment.
- Inspect before use for wear, deformation and pin engagement as outlined in ASME B30.26. (See full inspection guidelines below).
- Care should be exercised so that the shackle is not abused during use. When using shackles, it is important to:
- If necessary, use spacers on the shackle pin to assure that the shackle is not loaded at an angle. Load line of action should be through the center line of the shackle body and the middle of the shackle pin.
- The shackle should be protective coated with zinc plating or a galvanized finish if used in harsh environments.
- The shackle should not be subjected to high or low temperatures that could affect thermal treatment and the strength of the shackle. (Note: Per ASME B30.26 shackles are rated for temperatures between -40°F to 400°F.

SCREW PIN TIGHTENING

When tightening screw pins, it is important that shackle screw pin threads and the tapped threads in the shackle head are clean and free of burrs and damage. These conditions can cause an under-tightening of the shackle screw pin. The shackle screw pin should be tightly fitted into the shackle's leg opening until the treads engage and the shoulder of the screw pin makes contact with shackle body.

SIDE LOADING

When side loading a shackle with a single sling, the rated WLL will be reduced in accordance with the manufacturer's recommendation of a qualified person. ASME B30.26 also recommends reducing the capacity of a shackle when it is side loaded. (See figure below.) Note that only anchor shackles, like the one shown right, should be side loaded. Chain and long reach ("D"-shaped) shackles should not be side loaded.

ANCHOR SHACKLES FROM 3/16" TO 3"

Angles in Degrees	Working Load Limit Reduction
0° to 10°	0%
11° to 20°	15%
21° to 30°	25%
31° to 45°	30%
46° to 55°	40%
56° to 70°	45%
71° to 90°	50%

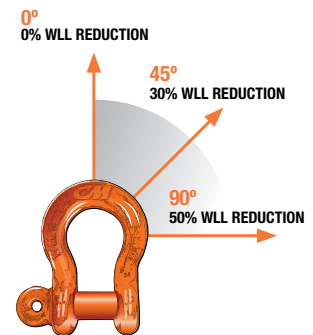

SYMMETRICAL LOADING

Shackles symmetrically loaded with two legs at a maximum included angle of 120° can be used to full working load limit. Side and symmetrical loading data applies to screw pin and bolt nut cotter anchor shackles as shown to the right.

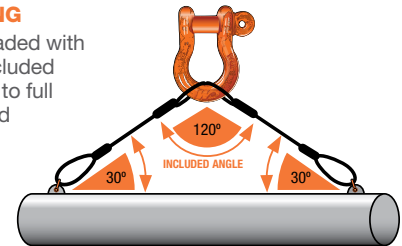

SIMPLY. SCALABLE. ACCESSIBLE.

SIMPLIFY YOUR SHACKLE INSPECTION AND INVENTORY MANAGEMENT WITH CM SMART ID™

CM Smart ID RFID technology is now offered as an option on select shackles—including some of the smallest CM shackles available. Smart ID makes shackle inspection more efficient and effective, allowing you to easily associate detailed inspection information with every shackle so you know they're safe to use. Smart ID also increases your productivity by enabling faster inventory tracking and serialization.

ACTUAL SIZE SHOWN → MORE INFO AT www.cmworks.com/rfid/cmsmartid

► SHACKLE INSPECTION

Shackles should be visually inspected before each use in line with ASME B30.26 regulations. Shackles should be discarded if any of the following conditions are apparent:

- Any parts are worn more than 10% of the original dimensions
- Load bearing components are bent, twisted, distorted, stretched, elongated, cracked or broken
- Excessive pitting, corrosion, nicks or gouges
- Indication of heat damage
- Missing or illegible manufacturer's name or trademark, working load limit or size
- Load pins have bent or visibly damaged threads
- Cotter pins or hairpin retainers are damaged

SUPER STRONG ANCHOR SHACKLES

WORKING LOAD LIMIT

1/2 to 55 TONS

CM Super Strong Shackles are carbon-type shackles with strength ratings that are 17 to 50% stronger than comparable-sized carbon shackles. As a result, these shackles are designed with a 6:1 design factor. Anchor shackles can be side loaded or used for multiple connections.

BENEFITS & FEATURES

- Manufactured from technically advanced micro alloy steel with optimal hardness for strength and ductility.
- Shackles show major deformation before failure.
- Working load limit and traceability codes shown as permanent markings on body.
- All shackles have alloy quenched and tempered pins.
- Available in sizes 3/16" to 2-1/2".
- Available finishes include powder coated, galvanized or self-colored.
- Shackles meet dimensional requirements and exceed performance requirements of RR-C-271.
- Special testing and certification is available upon request at the time of the order.
- Note:** Screw pin and bolt/nut/cotter shackles have a 6:1 design factor. Round pin shackles have 5:1 design factor.
- CM Smart ID RFID technology is available as an option on screw pin anchor shackles sizes 1/2" to 1-3/4" and bolt, nut & cotter shackles sizes 3/4" to 1-3/4".



SCREW PIN



ROUND PIN

BOLT, NUT & COTTER

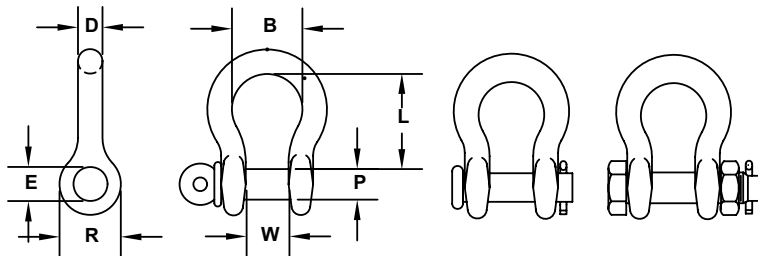

Size D (in.)	Working Load Limit (Ton)	Std. Pkg.	Weight (lbs.)	Product Code									Dimensions (in.)					
				Screw Pin			Round Pin			Bolt, Nut & Cotter			P	E	W	R	L	B (min.)
				Self Colored	Galva-nized	Orange Powder Coated	Self Colored	Galva-nized	Orange Powder Coated	Self Colored	Galva-nized	Orange Powder Coated						
3/16	1/2	50	0.06	M645	M645G	-	M345	M345G	-	-	-	-	0.25	0.29	0.38	0.57	0.88	0.58
1/4	3/4	50	0.12	M646	M646G	M646P	M346	M346G	M346P	M846	M846G	M846P	0.31	0.36	0.47	0.75	1.13	0.75
5/16	1	50	0.20	M647	M647G	M647P	M347	M347G	M347P	M847	M847G	M847P	0.38	0.45	0.53	0.84	1.25	0.81
3/8	1-1/2	50	0.30	M648	M648G	M648P	M348	M348G	M348P	M848	M848G	M848P	0.44	0.52	0.66	1.00	1.40	1.00
7/16	2	50	0.50	M649	M649G	M649P	M349	M349G	M349P	M849	M849G	M849P	0.50	0.58	0.72	1.15	1.69	1.19
1/2	3	50	0.75	M650	M650G	M650P	M350	M350G	M350P	M850	M850G	M850P	0.63	0.70	0.84	1.34	1.94	1.38
5/8	4-1/2	25	1.30	M651	M651G	M651P	M351	M351G	M351P	M851	M851G	M851P	0.75	0.83	1.06	1.66	2.41	1.63
3/4	6-1/2	10	2.30	M652	M652G	M652P	M352	M352G	M352P	M852	M852G	M852P	0.88	0.95	1.28	1.94	2.84	1.89
7/8	8-1/2	10	3.50	M653	M653G	M653P	M353	M353G	M353P	M853	M853G	M853P	1.00	1.09	1.44	2.14	3.31	2.06
1	10	5	5.00	M654	M654G	M654P	M354	M354G	M354P	M854	M854G	M854P	1.13	1.22	1.72	2.44	3.75	2.52
1-1/8	12	Bulk	7.00	M655	M655G	M655P	M355	M355G	M355P	M855	M855G	M855P	1.25	1.36	1.84	2.66	4.02	2.69
1-1/4	14	Bulk	9.50	M656	M656G	M656P	M356	M356G	M356P	M856	M856G	M856P	1.38	1.52	2.03	3.15	4.63	2.88
1-3/8	17	Bulk	12.50	M666	M666G	M666P	M366	M366G	M366P	M866	M866G	M866P	1.50	1.65	2.25	3.25	5.19	3.25
1-1/2	20	Bulk	17.20	M657	M657G	M657P	M357	M357G	M357P	M857	M857G	M857P	1.63	1.77	2.41	3.50	5.63	3.50
1-5/8	24	Bulk	23.50	M685	M685G	M685P	M385	M385G	M385P	M885	M885G	M885P	1.75	1.88	2.66	3.91	6.13	4.13
1-3/4	30	Bulk	27.70	M677	M677G	M677P	M377	M377G	M377P	M877	M877G	M877P	2.00	2.13	2.94	4.06	6.97	4.75
2	35	Bulk	39.00	M658	M658G	M658P	M358	M358G	M358P	M858	M858G	M858P	2.25	2.38	3.28	4.51	7.44	5.50
2-1/2	55	Bulk	90.50	-	-	-	-	-	-	MC860	MC860G	-	2.75	2.91	4.13	6.25	10.48	6.75

To order products with CM Smart ID RFID technology add "-RF" after the product number in the chart above. RFID-equipped rigging products are not eligible for our In-Stock Guarantee.

THEATRICAL SHACKLES PAINTED BLACK

WORKING LOAD LIMIT

1/2 to 10 TONS

BENEFITS & FEATURES

- Manufactured from technically advanced micro alloy material.
- Design factor 6:1.
- Working Load Limit and traceability codes shown as permanent marking on body.
- All shackles have alloy quenched and tempered pins.
- Available in sizes 3/16" to 1".
- Available in black powder coated finish only.
- Special testing and certification is available upon request at the time of the order.



Size D (in.)	Working Load Limit (Ton)	Standard Package	Weight (lbs.)	Product Code	Dimensions (in.)					
					P	E	W	R	L	B min
3/16	1/2	50	0.06	M645B	0.25	0.29	0.38	0.57	0.88	0.58
1/4	3/4	50	0.12	M646B	0.31	0.36	0.47	0.75	1.13	0.75
5/16	1	50	0.20	M647B	0.38	0.45	0.53	0.84	1.25	0.81
3/8	1-1/2	50	0.30	M648B	0.44	0.52	0.66	1.00	1.40	1.00
7/16	2	50	0.50	M649B	0.50	0.58	0.72	1.15	1.69	1.19
1/2	3	50	0.75	M650B	0.63	0.70	0.84	1.34	1.94	1.38
5/8	4-1/2	25	1.30	M651B	0.75	0.83	1.06	1.66	2.41	1.63
3/4	6-1/2	10	2.30	M652B	0.88	0.95	1.28	1.94	2.84	1.89
7/8	8-1/2	10	3.50	M653B	1.00	1.09	1.44	2.14	3.31	2.06
1	10	5	5.00	M654B	1.13	1.22	1.72	2.44	3.75	2.52

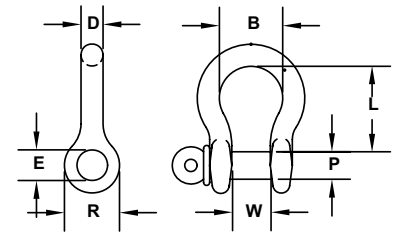

LONG REACH SHACKLE

WORKING LOAD LIMIT

7,000 to 50,000 lbs.

As one of the only manufacturers of long-reach shackles, we designed these shackles for use in construction applications where a longer reach is needed to attach to pick points.

BENEFITS & FEATURES

- Design factor 5:1.
- Meets the requirements of ASME B30.26.
- Alloy Steel.
- WLL forged on body.
- Offered in self-colored or durable orange powder coated finish.
- Do not point load. The load should be evenly distributed over the entire pin to achieve full working load limit.

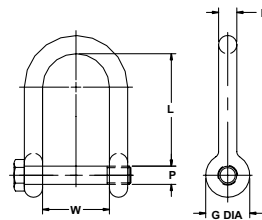

SCREW PIN

BOLT, NUT & COTTER

Size (in.)	Working Load Limit (lbs.)	Screw Pin			Bolt, Nut & Cotter			Dimensions (in.)				
		Product Code		Weight (lbs.)	Product Code		Weight (lbs.)	P	D	L	W	G
		Self Colored	Painted		Self Colored	Painted						
5/8	7,000	M7151	M7151P	1.80	M9151	M9151P	1.95	0.75	0.63	4.00	2.25	1.57
3/4	10,000	M7152	M7152P	2.72	M9152	M9152P	3.21	0.94	0.75	5.00	2.75	1.81
1	19,000	M7154	M7154P	5.86	M9154	M9154P	6.31	1.09	1.00	5.50	3.25	2.38
1-1/4	28,000	M7156	M7156P	11.90	M9156	M9156P	12.90	1.22	1.25	6.19	3.88	3.06
1-1/2	34,000	M7157	M7157P	19.60	M9157	M9157P	20.70	1.75	1.50	7.00	4.50	3.50
1-3/4	50,000	M7177	M7177P	30.70	M9177	M9177P	33.30	1.78	1.75	8.00	5.25	4.00

S.T.A.C. CHAIN

SPECIAL THEATRICAL ALLOY CHAIN

WORKING LOAD LIMIT

6 TONS

For theatrical rigging applications where bridle adjustability is required

BENEFITS & FEATURES

SUPER STRENGTH

Grade 80 alloy material with 1/2" diameter and 6 ton working load limit.

4:1 DESIGN FACTOR

Meets or exceeds worldwide standards.

MEETS EUROPEAN STANDARDS FOR LONG LINK CHAIN

PROOF TESTED

Each link proof tested to assure weld and material integrity.

HEAT TREATED

Alloy steel provides long life.

FIRE & ABRASION RESISTANT

POSITIVE AND EASY ID

Chain embossed with "STAC-8" and "CM USA" for easy identification as CM alloy. Also tagged with size, grade, reach and working load limit.

VERSATILITY

Link accepts up to 3/4" shackle for adjustability.

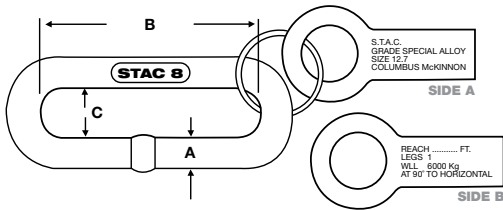

SPECIFICATIONS

Chain Size (in.)	Working Load Limit (lbs.)	Nominal Chain Dimensions (in.)			Per Foot		Per Drum		
		Material Diameter A	Inside Length B	Inside Width C	Product Code	Weight (lbs./ft.)	Length (ft.)	Product Code	Weight (lbs.)
1/2	12,000	0.53	3.74	0.91	695550	2.03	250	695550D250	506.75
							500	695550D500	1,013.50

S.T.A.C. CHAIN SETS

SPECIAL THEATRICAL ALLOY CHAIN



BENEFITS & FEATURES

- Cut to desired length to meet your needs.
- Each assembly tagged with reach and length.
- Black finish.
- Fits and functions with the CM line of black shackles.
- Wide links allow for easy hook up.

Chain Size (in.)	Length (ft.)	Cut Length Product Code	Weight (lbs.)
1/2	3	695575	6.70
	4	695576	9.94
	5	695577	11.96
	6	695578	13.99
	7	695579	16.01
	8	695580	18.03
	9	695581	20.05
	10	695582	22.07
	11	695583	24.10
	12	695584	26.12
	13	695585	28.14
	14	695586	30.16
	15	695587	32.18

WIRE GRIPS

CAPACITIES

1,000 to 20,000 lbs.

BENEFITS & FEATURES

EASY TO USE

- **VERSATILITY**
All models are rated for a variety of wire sizes and types, so fewer grip changes are required.
- **NO LOCK-UPS**
Grips open easily and release instantly to quickly insert or remove wire.
- **LARGE HANDLE EYE OPENING**
Accepts standard hooks and easily attaches to tackle blocks.
- **CHOICE OF DESIGN**
Spring-loaded or non-spring-loaded models available.

RUGGED AND PORTABLE

- **FORGED STEEL CONSTRUCTION**
Durable yet lightweight.
- **YELLOW CHROMATE FINISH**
Protects components from rust and corrosion.

HOT LINE MODELS

- **SPRING-LOADED GATE**
Standard on all hot line models. Lineman can use a holding stick to open the gate and place the grip on the wire. When released, the gate closes over the wire and prevents the grip from falling off the wire.
- **LOCKING MECHANISM**
Notched handle on spring-loaded models locks grip in open position for placement on or removal from wire, then releases instantly.

JAW OPTIONS

- **REPLACEMENT JAW**
Machined with large, aggressive teeth. Available on 5000 and 10,000 lb. models – suitable for applications requiring exclusive use on EHS cable or guy strand.

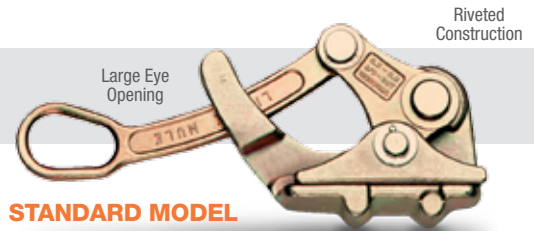

STANDARD MODEL
(Spring-Loaded)



HOT LINE MODEL
(Non-Spring-Loaded)



HOT LINE MODEL
(Spring-Loaded)

JAW AND TEETH CONFIGURATIONS

1000 & 2000 LB.

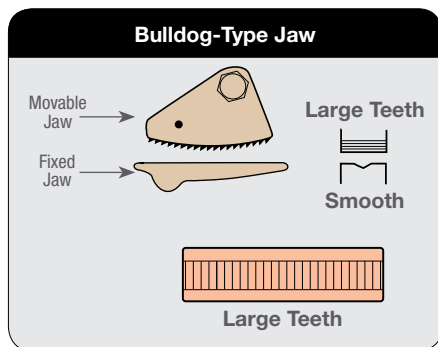

5000 & 10,000 LB.

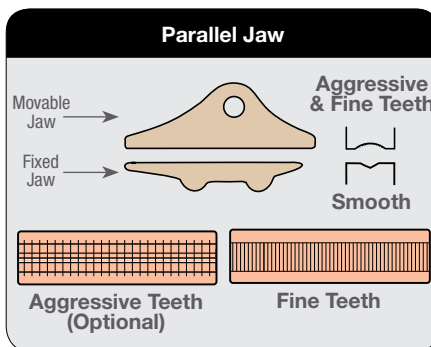

12,000 & 20,000 LB.

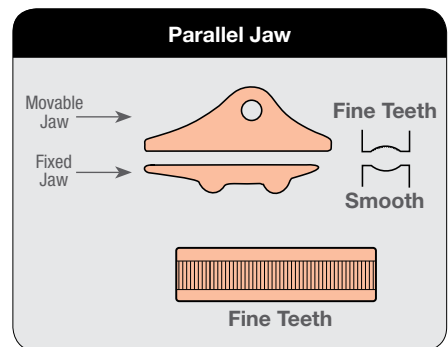

Product Code	Type	Capacity (lbs.)	Weight (lbs.)	Wire Size				Handle Eye Opening (in.)
				Minimum		Maximum		
				Size (in.)	Gauge	Size (in.)	Gauge	
LMG1000*	Standard Grip (Spring Loaded)	1000	0.50	.040	18AWG	0.394	1/0AWG	0.625 dia.
LMG2000*		2000	1.00	.109	8AWG	0.594	4/0AWG	1 x 1.25
LMG4500		5000	3.25	.180	6AWG	0.600	4/0AWG	1.25 x 1.75
LMG4600		10000	4.25	.300	1AWG	0.800	450MCM	1.25 x 1.75
LMG4800		12000	8.00	.700	397MCM	1.250	1130MCM	1.25 x 1.75
LMG4700		20000	21.00	.700	397MCM	1.250	1130MCM	2.5 x 3.5
LMG4501	Hot Line Grip (Spring Loaded) (Notched Handle)	5000	3.75	.180	6AWG	0.600	4/0AWG	1.25 x 1.75
LMG4601		10000	4.50	.300	1AWG	0.800	450MCM	1.25 x 1.75
LMG4801		12000	8.00	.700	397MCM	1.250	1130MCM	1.25 x 1.75
LMG4701		20000	21.00	.700	397MCM	1.250	1130MCM	2.5 x 3.5
LMG4502	Hot Line Grip (Not Spring Loaded) (No Notched Handle)	5000	3.25	.180	6AWG	0.600	4/0AWG	1.25 x 1.75
LMG4602		10000	4.50	.300	1AWG	0.800	450MCM	1.25 x 1.75
LMG4802		12000	8.00	.700	397MCM	1.250	1130MCM	1.25 x 1.75
LMG4702		20000	21.00	.700	397MCM	1.250	1130MCM	2.5 x 3.5

* Note: 1000 and 2000 Lb. Models Have Bulldog-Type Jaw. All Other Models Have Parallel Jaw.

TURNBUCKLES

WORKING LOAD LIMIT

400 to 21,400 lbs.

BENEFITS & FEATURES

- Turnbuckles can be used to apply tension to wire rope or cable.
- Composed of a forged body and two end fittings. End fittings can be eyes, jaws, or hooks.
- Must only be applied to loads within their working load limit as specified for the particular end fitting being applied.
- Apply turnbuckles in a straight in-line manner only. Do not allow anything to contact the turnbuckle body or end attachment threaded shanks.
- Apply load to the center of end attachment eyes and bowl of hooks. Do not tip load hooks or side load eyes.
- Design factor 5:1.



Eye & Eye



Jaw & Eye



Jaw & Jaw



Hook & Eye



Hook & Hook

WARNING

Improper use or care of turnbuckles can result in bodily injury or property damage. To avoid injury:

- Inspect turnbuckles for distortion and wear.
- Do not use if anything is in contact with the turnbuckle body or an end fitting.
- Only apply load to center of eyes and bowl of hooks.
- Do not exceed working load limit.



TURNBUCKLE LOCK NUTS

Size (in.)	Product Code		Weight (lbs.)
	Right Hang Nut	Left Hang Nut	
1/4	3X845	3X845L	0.005
5/16	-	3X846L	0.008
3/8	3X847	3X847L	0.010
1/2	3X849	3X849L	0.030
5/8	-	3X850L	0.050
3/4	-	3X851L	0.090
7/8	-	3X852L	0.130
1	-	3X853L	0.200
1-1/4	-	3X855L	0.410
1-1/2	-	3X866L	0.700

Imported. Hot Dip Galvanized.

WWW.CM-ET.COM

Eye & Eye		Jaw & Eye		Jaw & Jaw		Thread Diameter (in.)	Take Up (in.)	WLL (lbs.)	Weight (lbs.)
Product Code	Weight (lbs.)	Product Code	Weight (lbs.)	Product Code	Weight (lbs.)				
0404EE	0.3	0404JE	0.3	0404JJ	0.4	1/4	4	500	0.4
0504EE	0.5	0504JE	0.5	0504JJ	0.6	5/16	4.5	800	0.6
0606EE	0.8	0606JE	0.9	0606JJ	0.9	3/8	6	1,200	0.9
0806EE	1.5	0806JE	1.7	0806JJ	1.8	1/2	6	2,200	1.8
0809EE	1.9	0809JE	2.0	0809JJ	2.1	1/2	9	2,200	2.1
0812EE	2.3	0812JE	2.4	0812JJ	2.4	1/2	12	2,200	2.4
1006EE	2.5	1006JE	3.0	1006JJ	3.0	5/8	6	3,500	3.0
1009EE	3.3	1009JE	3.5	1009JJ	3.7	5/8	9	3,500	3.7
1012EE	3.8	1012JE	4.0	1012JJ	4.2	5/8	12	3,500	4.2
1206EE	3.9	1206JE	4.3	1206JJ	4.6	3/4	6	5,200	4.6
1209EE	4.8	1209JE	5.1	1209JJ	5.4	3/4	9	5,200	5.4
1212EE	5.4	1212JE	5.7	1212JJ	6.0	3/4	12	5,200	6.0
1218EE	7.0	1218JE	7.3	1218JJ	7.7	3/4	18	5,200	7.7
1412EE	7.4	1412JE	7.9	1412JJ	8.4	7/8	12	7,200	8.4
1418EE	9.6	1418JE	10.2	1418JJ	10.7	7/8	18	7,200	10.7
1606EE	9.0	1606JE	9.4	1606JJ	9.7	1	6	10,000	9.7
1612EE	11.2	1612JE	11.6	1612JJ	11.9	1	12	10,000	11.9
1618EE	13.8	1618JE	14.3	1618JJ	14.8	1	18	10,000	14.8
1624EE	17.1	1624JE	17.6	1624JJ	18.2	1	24	10,000	18.2
2012EE	20.9	-	-	2012JJ	23.8	1-1/4	12	15,200	23.8
2018EE	25.7	-	-	2018JJ	27.5	1-1/4	18	15,200	27.5
2024EE	29.7	-	-	2024JJ	33.7	1-1/4	24	15,200	33.7
2412EE	29	-	-	2412JJ	38.1	1-1/2	12	21,400	38.1
2418EE	35.2	-	-	2418JJ	44.2	1-1/2	18	21,400	44.2
2424EE	40.7	-	-	2424JJ	48.4	1-1/2	24	21,400	48.4

Imported.

Product Code		Thread Diameter (in.)	Take Up (in.)	WLL (lbs.)	Weight (lbs.)
Hook & Eye	Hook & Hook				
0404HE	0404HH	1/4	4	400	-
0504HE	0504HH	5/16	4-1/2	700	-
0606HE	0606HH	3/8	6	1,000	0.8
0806HE	0806HH	1/2	6	1,500	1.5
0809HE	0809HH	1/2	9	1,500	1.9
0812HE	0812HH	1/2	12	1,500	2.3
1006HE	1006HH	5/8	6	2,250	2.5
1009HE	1009HH	5/8	9	2,250	3.3
1012HE	1012HH	5/8	12	2,250	3.8
1206HE	1206HH	3/4	6	3,000	3.9
1209HE	1209HH	3/4	9	3,000	4.8
1212HE	1212HH	3/4	12	3,000	5.4
1218HE	1218HH	3/4	18	3,000	7.0
1412HE	1412HH	7/8	12	4,000	7.4
1418HE	1418HH	7/8	18	4,000	9.6
1606HE	1606HH	1	6	5,000	9.0
1612HE	1612HH	1	12	5,000	11.2
1618HE	1618HH	1	18	5,000	13.8
1624HE	1624HH	1	24	5,000	17.1
2418HE	2418HH	1-1/2	18	7,500	31.2
2424HE	2424HH	1-1/2	24	7,500	38.2

Imported.

CARE & INSPECTION

Inspect turnbuckles before use for bent components and worn threads. Do not use if body or end fitting is bent more than 10° from the axial center line. Do not use if threads are visibly worn or feel loose. If in doubt, consult a rigging handbook or discuss with a qualified person.

CHAIN INFORMATION

Chain Size (in.)	Wire Diameter Nominal (in.)	Inside Length Nominal (in.)	Inside Width Nominal (in.)	Weight Per 100 ft (lbs.)	Working Load Limit (lbs.)
GRADE 30 (PROOF COIL)					
3/16	0.22	0.97	0.45	39.8	800
1/4	0.28	1.22	0.51	64.6	1,300
5/16	0.33	1.27	0.60	97.6	1,900
3/8	0.39	1.35	0.58	140.2	2,650
1/2	0.50	1.73	0.81	227.0	4,500
5/8	0.63	1.92	0.86	363.0	6,900
3/4	0.78	2.40	1.07	568.0	10,600
GRADE 43 (HIGH TEST)					
1/4	0.28	1.22	0.51	64.6	2,600
5/16	0.34	1.25	0.54	104.0	3,900
3/8	0.39	1.35	0.58	140.3	5,400
1/2	0.50	1.73	0.81	227.0	9,200
5/8	0.63	1.92	0.86	363.0	13,000
3/4	0.78	2.40	1.07	568.0	20,200
GRADE 70 (TRANSPORT)					
1/4	0.39	0.84	0.47	76.4	3,150
5/16	0.33	0.98	0.46	100.5	4,700
5/16	0.33	1.10	0.50	96.9	4,700
3/8	0.39	1.14	0.54	145.5	6,600
3/8*	0.39	1.38	0.60	136.5	6,600
1/2	0.53	1.56	0.73	267.0	11,300

* Standard Link Grade 70 Chain

Chain Size (in.)	Wire Diameter Nominal (in.)	Inside Length Nominal (in.)	Inside Width Nominal (in.)	Weight Per 100 ft (lbs.)	Working Load Limit (lbs.)
HERC-ALLOY 800® (GRADE 80)					
7/32	0.22	0.68	0.31	44.3	2,100
9/32	0.28	0.88	0.40	72.9	3,500
5/16	0.32	1.02	0.46	90.9	4,500
3/8	0.39	1.25	0.57	144.0	7,100
1/2	0.51	1.44	0.73	255.0	12,000
5/8	0.63	1.78	0.86	382.3	18,100
3/4	0.79	2.23	1.07	595.0	28,300
7/8	0.88	2.25	1.14	776.0	34,200
1	1.00	3.07	1.49	941.0	47,700
1-1/4	1.25	3.92	1.74	1,420.0	72,300
HERC-ALLOY® 1000 (GRADE 100)					
7/32	0.22	0.68	0.31	44.3	2,700
9/32	0.28	0.88	0.40	72.9	4,300
3/8	0.39	1.25	0.57	144.0	8,800
1/2	0.51	1.56	0.73	246.0	15,000
5/8	0.63	1.92	0.86	370.0	22,600
3/4	0.79	2.40	1.07	577.0	35,300

HERC-ALLOY 800® CHAIN

WORKING LOAD LIMIT

2,100 to 72,300 lbs.

BENEFITS & FEATURES

- A higher strength heat treated alloy steel chain primarily used as a sling component for overhead lifting.
- Can be used in rigging and tie down applications where a lighter weight, higher strength chain is desirable.
- Recommended for overhead lifting by NACM, ASME, and OSHA.
- Design factor 4:1

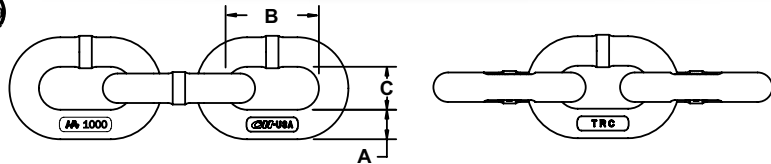

Chain Size (in.)	Working Load Limit (lbs.)	Nominal Chain Dimensions (in.)			Per Foot			Per Drum		
		Material Diameter A	Inside Length B	Inside Width C	Product Code	Weight (lbs./ft.)	Approximate Number of Links (per ft.)	Product Code	Length (ft.)	Weight (lbs.)
7/32	2,100	0.22	0.68	0.31	607020	0.44	17.8	677010	800	354
9/32	3,500	0.28	0.88	0.40	607028	0.73	13.6	677011	500	365
5/16	4,500	0.32	1.02	0.46	607031	0.91	11.8	-	-	-
3/8	7,100	0.39	1.25	0.57	607037	1.44	9.6	677013	500	719
1/2	12,000	0.51	1.44	0.73	607050	2.55	8.3	677015	300	765
5/8	18,100	0.63	1.78	0.86	607062	3.82	6.8	677016	200	765
3/4	28,300	0.79	2.23	1.07	607075	5.95	5.4	677017	100	595
7/8	34,200	0.88	2.25	1.14	607087	7.76	5.3	677018	100	776
1	47,700	1.00	3.07	1.49	607101	9.41	3.9	677019	100	941
1-1/4	72,300	1.25	3.92	1.74	607128	14.20	3.1	677070	90	1,278

PROOF COIL CHAIN GRADE 30

WORKING LOAD LIMIT

800 to 10,600 lbs.



Grade 30 chain, commonly called Proof Coil, is manufactured to meet ASTM & NACM specifications. Typical uses include barrier chains, trailer safety chains, light construction, marine industry, etc. Grade 30 chain is available in a wide assortment of finishes and packaged configurations. It should not be used for overhead lifting.

BENEFITS & FEATURES

- Meets ASTM & NACM standards.
- Available in a wide assortment of finishes including, Self-Colored, Zinc Plated, Galvanized, Powder Coated
- Permanent identification on chain. (embossed with CM30)
- 100% proof tested
- Available in drums, pails and multiple styles of assemblies.
- Design factor 4:1.

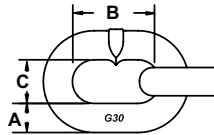

Chain Size (in.)	Working Load Limit (lbs.)	Nominal Chain Dimensions (in.)			Weight* (lbs./ft.)	Approximate Number of Links (per ft.)
		Material Diameter A	Inside Length B	Inside Width C		
3/16	800	0.22	0.97	0.45	0.40	12.4
1/4	1,300	0.28	1.22	0.51	0.65	9.9
5/16	1,900	0.33	1.27	0.60	0.98	9.5
3/8	2,650	0.39	1.35	0.58	1.40	8.9
1/2	4,500	0.50	1.73	0.81	2.27	6.9
5/8	6,900	0.63	1.92	0.86	3.63	6.3
3/4	10,600	0.78	2.40	1.07	5.68	5.0

Chain Size (in.)	Self-Colored Finish				Zinc Plated Finish						Hot Dipped Galvanized Finish					
	Full Drum		Half Drum		Full Drum		Half Drum		Pail		Full Drum		Half Drum		Pail	
	Product Code	Length (ft.)	Product Code	Length (ft.)	Product Code	Length (ft.)	Product Code	Length (ft.)	Product Code	Length (ft.)	Product Code	Length (ft.)	Product Code	Length (ft.)	Product Code	Length (ft.)
Import																
3/16	671040	850	-	-	671440	850	-	-	671410	250	671340	850	671394	500	-	-
1/4	671041	800	671091	400	671441	800	671491	400	671411	140	671341	800	671391	400	-	-
5/16	671042	550	671092	275	671442	550	671492	275	671412	90	671342	550	-	-	-	-
3/8	671043	400	671093	200	671443	400	-	-	671413	60	671343	400	671393	200	-	-
North American																
1/2	-	-	671045	200	671445	200	-	-	671415	40	671345	200	-	-	-	-
5/8	671046	150	-	-	-	-	-	-	-	-	671346	150	-	-	-	-
3/4	671047	100	-	-	-	-	-	-	-	-	671347	100	-	-	-	-

* Weight for Hot Dipped Galvanized Finish: Add 5% for sizes under 1/2", Add 2% for sizes over 1/2"

WIRE ROPE CLIPS

- Wire Rope Clips are used to secure the end of wire rope when forming a loop; i.e., for wire rope turn-back. Clips are available in two configurations: mid-grip (double saddle) and single saddle. Each configuration is equally strong and effective, but care must be exercised for proper installation of single saddle clips; i.e., saddle must rest against live end of wire rope. All clips should be used in conjunction with a wire rope thimble and may require torquing.



NOTE: Wire rope clips are not recommended for fabricating slings for overhead lifting. Reference ASME B30.9 for special applications.

QUICK LINKS

- Afford quick and easy chain repair and/or attachment of fittings. Easy closing by threading nut onto threaded end. Reusable. Available in stock diameters ranging from 1/8" to 1/2". Not to be used for overhead lifting, and prohibited for all load securement applications by CVSA

SHOULDER EYE BOLTS

- Forged steel/quenched and tempered.
- Metric sizes available.
- Recommended for straight line pull.



EYE SWIVELS

- Hot dip galvanized.
- Ultimate load is 5 times working load limit.
- Meets the performance requirements of RR-C-271D, Type VII, Class 2.
- Made in U.S.A.
- Regular forged eye and eye swivels.



MASTER LINK

DUAL RATED FOR USE WITH HA800 OR HA1000

WORKING LOAD LIMIT

3,600 to 187,800 lbs.

BENEFITS & FEATURES

- Accepts both Herc-Alloy® 1000 & 800 chain and components.
- Durable orange powder coated finish.
- May be used for mechanical and welded sling assemblies.
- 100% proof tested.
- Design factor 4:1



Trade Size (in.)	Working Load Limit (lbs.)	Catalog Number	Product Code	Nominal Dimensions (in.)			Weight (lbs.)	Type and Size of Grade 80 Chain Sling (in.)	
				Material Diameter A	Inside Length B	Inside Width C		Single	Double
Standard Sizes (DUAL RATED THROUGH 1-3/4" SIZE ONLY)									
3/8	5,400	HA40	555231	0.41	3.00	1.50	0.33	7/32 & 9/32	7/32
1/2	8,600	HA50	555232	0.56	5.00	2.50	1.02	3/8	9/32
3/4	17,600	HA75	555235	0.75	5.50	2.75	2.08	1/2	3/8
1	30,000	HA100	555238	1.00	7.00	3.50	4.59	5/8 & 3/4	1/2
1-1/4	45,200	HA125	555240	1.25	8.75	4.38	9.31	7/8	5/8
1-1/2	70,600	HA150	555243	1.50	10.50	5.25	15.60	1	3/4 & 7/8
1-3/4	105,900	HA175	555246	1.75	12.00	6.00	24.40	1-1/4	1
2*	88,900	HA200	554949	2.00	14.00	7.00	38.00	1-1/4	1
2-1/4*	125,200	HA225	554951	2.25	16.00	8.00	55.00	–	1-1/4
2-3/4*	187,800	HA275	554957	2.75	16.00	9.00	84.84	–	–
Special Sizes (NOT DUAL RATED)									
1	18,200	N/A	554969	1.00	8.00	4.00	5.25	N/A	N/A
1-1/4	22,800		554942	1.25	12.00	6.00	12.08		
1-1/2	36,700		554944	1.50	14.00	7.00	20.16		
1-1/2	42,900		554970	1.50	12.00	6.00	17.60		
1-3/4	57,100		554945	1.75	14.00	7.00	27.92		
2	77,800		554952	2.00	16.00	8.00	43.00		

NOTE: Standard sizes dual rated through 1-3/4" only. Special sizes not dual rated.

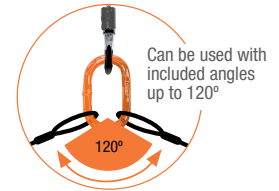
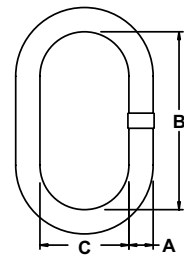

HAMMERLOK®

DUAL RATED FOR USE WITH HA800 OR HA1000

WORKING LOAD LIMIT

2,700 to 35,300 lbs.

BENEFITS & FEATURES

- Used for overhead lifting slings to connect chain branches to the master link and the hook to attachments.
- Constructed of drop forged alloy steel.
- Can be used with Grade 100 and Grade 80 chain.
- Must be matched to chain size.
- Do not use for chain repair or splicing.
- Meets ASTM A952 standards.
- Design factor 4:1

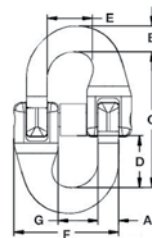

Size (in.)	Working Load Limit (lbs.)	Product Code	Load Pin Kit Product Code	Dimensions (in.)							Weight (lbs.)
				A (Max)	B (Max)	C	D	E	F	G	
7/32	2,700	667021-2	R667021-2	0.29	0.28	1.85	0.69	0.61	1.44	0.52	0.27
9/32	4,300	667028-2	R667028-2	0.37	0.44	1.94	0.69	0.68	1.58	0.61	0.28
3/8	8,800	667038-2	R667038-2	0.52	0.50	3.02	1.15	1.05	2.33	0.81	0.84
1/2	15,000	667050-2	R667050-2	0.64	0.68	3.79	1.43	1.29	2.98	1.10	1.87
5/8	22,600	667062-2	R667062-2	0.81	0.91	4.50	1.70	1.54	3.57	1.32	3.13
3/4	35,300	667075-2	R667075-2	0.97	1.07	5.36	2.06	1.78	4.69	1.52	5.75

CLEVLOK® SLING HOOK

DUAL RATED FOR USE WITH HA800 OR HA1000

WORKING LOAD LIMIT

2,700 to 35,300 lbs.

BENEFITS & FEATURES

- For use with both Grade 80 & 100 chain.
- Available with and without a latch.
- Quench and tempered alloy steel.
- Clevlok head design.
- 100% proof tested and fatigue rated.
- Durable orange powder coated finish.
- Improved forged latch.
(hook available with or without latch)
- Replacement pin and latch kit available.
- New CE compliant hooks and latches.
- Meets EN 1677, ASTM A953 and ASME B30.10 standards.
- Design factor 4:1

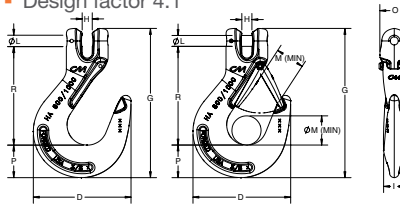

Size (in.)	Working Load Limit (lbs.)	Standard Package	Product Code					Dimensions (in.)										Weight (lbs.)
			With Latch	Without Latch	Latch Kit	Alloy Load Pin	Retaining Pin	D	G	H	I	L	M	O	P	R		
7/32	2,700	10	657716	557716	4X455321	SP595778	495826	3.05	5.00	0.31	0.66	0.28	0.96	1.13	0.94	3.45	1.10	
9/32	4,300	10	657718	557718	4X455322	595780SP	495825	3.53	5.55	0.38	0.75	0.36	0.83	1.32	1.11	3.75	1.20	
3/8	8,800	10	657719	557719	4X455325	595781	495825	4.54	6.93	0.47	1.00	0.51	1.06	1.34	1.51	4.58	2.21	
1/2	15,000	5	657720	557720	4X455328	595782	495823	5.48	8.28	0.58	1.33	0.63	1.38	1.87	1.55	5.59	4.22	
5/8	22,600	5	657721	557721	4X455329	SP595783P	495849	6.20	9.61	0.71	1.47	0.75	1.69	2.11	1.83	6.44	6.64	
3/4	35,300	Bulk	657722	557722	4X455330	595786	495824	7.63	11.79	0.88	1.88	0.94	2.09	2.55	2.51	7.74	11.22	

EYE SLING HOOK

DUAL RATED FOR USE WITH HA800 OR HA1000

WORKING LOAD LIMIT

2,700 to 72,300 lbs.

BENEFITS & FEATURES

- For use with both Grade 80 & 100 chain.
- Available with and without latch.
- Quench and tempered alloy steel.
- 100% proof tested.
- Fatigue rated.
- Hook available with and without latch (replacement latch available).
- Durable orange powder coated finish.
- Design factor 4:1

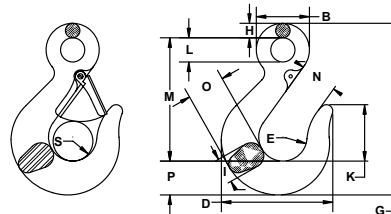

Size (in.)	Working Load Limit (lbs.)	Standard Package	Product Code			Dimensions (in.)														Weight (lbs.)
			With Latch	Without Latch	Latch Kit	B	D	E	G	H	I	K	L	M	N	O	P	S		
7/32	2,700	10	558618	458618	4X458321	1.50	3.04	1.03	5.06	0.38	0.66	1.48	0.75	3.75	1.17	0.98	0.94	0.96	0.8	
9/32	4,300	10	558622	458622	595523	1.63	3.50	1.50	5.25	0.44	0.73	1.59	0.75	3.75	1.19	1.20	1.05	1.06	1.10	
3/8	8,800	10	558625	458625	595525	2.06	4.33	1.88	6.64	0.56	0.95	2.19	0.94	4.78	1.44	1.45	1.28	1.31	1.90	
1/2	15,000	5	558628	458628	595528	2.63	5.50	2.25	8.16	0.75	1.17	2.56	1.13	5.69	1.78	1.94	1.66	1.63	4.30	
5/8	22,600	5	558629	458629	595529	3.06	6.34	2.63	9.66	0.88	1.44	2.63	1.31	6.50	2.03	2.38	2.19	1.75	7.30	
3/4	35,300	Bulk	558630	458630	595530	3.50	7.83	3.00	11.38	1.00	1.69	3.44	1.50	7.81	2.50	2.83	2.51	2.19	12.50	
7/8*	34,200	Bulk	558332	458732	595532	3.88	8.59	3.38	12.72	1.09	1.94	3.88	1.69	8.75	2.78	3.22	2.84	2.38	18.10	
1*	47,700	Bulk	558333	458733	595533	4.31	9.59	4.00	14.23	1.22	2.14	4.25	1.88	9.88	3.13	3.55	3.09	2.88	22.60	
1-1/4*	72,300	Bulk	558335	458735	595535	5.31	11.56	4.66	17.00	1.50	2.62	4.64	2.31	11.50	3.88	4.25	3.89	3.41	47.00	

* Herc-Alloy 800® only

CM HURRICANE 360[°]™ HAND CHAIN HOIST

CAPACITIES

1/2 to 10 ton

LIFT

up to 20 FT. standard

WARRANTY

5 years

The CM Hurricane 360[°]™ provides ultimate flexibility for a wide range of applications. The patented hand chain cover rotates a full 360 degrees, allowing operators to lift, pull or position loads from virtually any angle without standing under them.

BENEFITS & FEATURES

OPERATE FROM ANY ANGLE

360 degree rotating hand cover allows the hoist to be operated at any angle from any location, even inverted.

STANDARD LOAD LIMITER

For simple, automatic overload protection.

BRAKING POWER

Double pawl Weston-Style braking system provides reliable positive load control.

POWDER COATED FINISH

For corrosion protection.

HEAT TREATED STEEL GEARING

All internal gears and pinions are heat treated steel for high strength and long life.

CHAIN GUIDE AND STRIPPER

Assures load chain alignment.

PRECISION 4-POCKET LIFTWHEEL

Fully machined for better chain fit and reduced wear allowing for accurate movement of the load chain.

HARDENED STEEL CHAIN

Alloy steel load chain assures high strength and long wear life.

MINIMAL MAINTENANCE

Easily disassembled, requiring no special tools.

MEETS ASME B30.16

And European CE Standard.



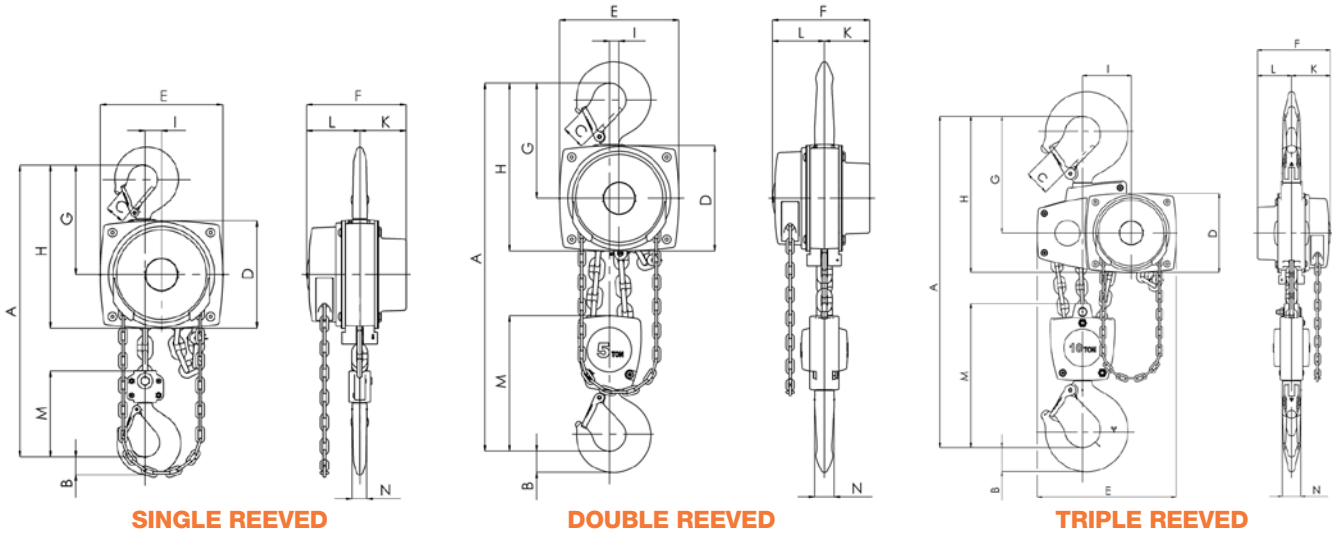

SINGLE REEVED

DOUBLE REEVED

TRIPLE REEVED

SPECIFICATIONS

Product Code	Load Rating Tons (kg)	Lift		Weight (lbs.)	Hand Chain Pull to Lift Rated Load lbs. (kg)	Hand Chain Overhauled to Lift Load One Foot ft. (m)	Dimensions in inches (mm)												
		ft.	m.				A	B	C	D	E	F	G	H	I	K	L	M	N
5632A	1/2 (500)	Less Chain		20	44 (20)	30 (9.1)	11.811 (300)	0.669 (17)	0.945 (24)	5.236 (133)	5.827 (148)	5.827 (148)	5.472 (139)	8.110 (206)	0.945 (24)	2.402 (61)	3.425 (87)	4.331 (110)	0.551 (14)
5623A		10	3	23															
5624A		15	4.5	28															
5625A		20	6	33															
5651A		30	9	43															
5633A	1 (1,000)	Less Chain		21	54 (24)	49 (14.9)	13.189 (335)	0.866 (22)	1.142 (29)	6.142 (156)	6.890 (175)	6.575 (167)	6.457 (164)	9.528 (242)	0.945 (24)	2.756 (70)	3.819 (97)	4.921 (125)	0.748 (19)
5626A		10	3	26															
5627A		15	4.5	33															
5628A		20	6	41															
5653A		30	9	58															
5634A	2 (2,000)	Less Chain		26	74 (34)	71 (21.6)	15.551 (395)	1.181 (30)	1.378 (35)	7.165 (182)	7.992 (203)	7.638 (194)	7.559 (192)	11.142 (283)	1.220 (31)	3.268 (83)	4.370 (111)	6.142 (156)	0.866 (22)
5629A		10	3	45															
5630A		15	4.5	48															
5631A		20	6	51															
5638A	3 (3,000)	Less Chain		56	92 (42)	87 (26)	20.472 (520)	1.496 (38)	1.575 (40)	8.661 (220)	9.843 (250)	8.622 (219)	8.858 (225)	13.189 (335)	1.339 (34)	3.740 (95)	4.882 (124)	7.008 (178)	1.181 (30)
5635A		10	3	68															
5636A		15	4.5	79															
5637A		20	6	90															
5642A	5 (5,000)	Less Chain		80	76 (34)	174 (53)	25.748 (654)	1.772 (45)	1.850 (47)	8.661 (220)	9.843 (250)	8.622 (219)	9.528 (242)	13.858 (352)	0.827 (21)	3.740 (95)	4.882 (124)	11.220 (285)	1.457 (37)
5639A		10	3	122															
5640A		15	4.5	142															
5641A		20	6	162															
5646A	10 (10,000)	Less Chain		120	102 (46)	261 (79.3)	32.480 (825)	2.677 (68)	2.677 (68)	8.661 (220)	15.079 (383)	8.622 (219)	12.835 (326)	17.165 (436)	5.354 (136)	3.740 (95)	4.882 (124)	15.787 (401)	1.969 (50)
5643A		10	3	210															
5644A		15	4.5	240															
5645A		20	6	270															

CM BANDIT™ RATCHET LEVER HOIST

CAPACITIES

3/4, 1-1/2, 3 & 6 ton
Metric Rated

LIFT

up to 20 FT. standard
Longer lifts are available

The CM Bandit™ is one of the most compact and durable ratchet lever hoists in the industry. Its lightweight and portable design, easy free-chaining feature and 360° rotating handle make it one of the most versatile hoists on the market today. Now available in 3/4, 1-1/2, 3 and 6 ton capacities for all of your pulling and lifting needs.

BENEFITS & FEATURES

COMPACT & PORTABLE DESIGN

Rugged, yet lightweight, design and construction allow the Bandit to be easily transported and used in even the most confining spaces.

OUR FIRST HOIST WITH CM SMART ID™ RFID TECHNOLOGY!

- Standard on all U.S. Bandit units.
- Chip associated with detailed product information at the factory.

FREE-CHAINING

Easy free-chaining feature allows for quick take up and positioning of slack chain. Designed not to accidentally free chain while under load.

360° ROTATING HANDLE

Full rotation of handle allows for versatile rigging options when working in tight spaces.

LOW HANDLE EFFORT

Double reduction gearing provides easy operation with minimal handle effort.

COMFORT-FIT HANDLE

Screwed-on comfortable rubber grip makes for a secure hold in all environments.

LOAD SECURITY & EASY INSPECTION

Upper and lower hooks feature standard cast safety latches that provide positive and secure load engagement. Hooks are bolted on for easy removal and inspection.

MEETS ASME B30.21 POSITIVE LOAD CONTROL

Enclosed Weston-type load brake stays clean and dry for positive load positioning.

OPTIONAL FEATURES

OPTIONAL SHIPYARD HOOKS

Shipyards hooks are available as an option on 1-1/2 & 3 ton units.

OPTIONAL INTERNAL LOAD LIMITER

Allows the handle to rotate but will not lift if load exceeds 125% of the working load limit.

EASY TO POSITION & ATTACH

Upper and lower hooks feature extra-wide throat openings to allow for easier attachment to pick points. Hooks swivel 360° for faster positioning.

BUILT TO LAST

Impact-resistant stamped steel housing withstands repeated rigorous use.

CORROSION RESISTANT

Standard powder coat finish on housing and zinc plating on major components for extra protection against corrosion when working in harsh environments.

100% LOAD TESTED GOLD CHROMATE CHAIN

Proven chain integrity and corrosion resistance.

EASY IDENTIFICATION

Each unit has a unique serial number for easy and accurate identification.

SHIPS IN 3 DAYS – GUARANTEED

1-1/2 & 3 ton units are eligible for our In-Stock Guarantee.



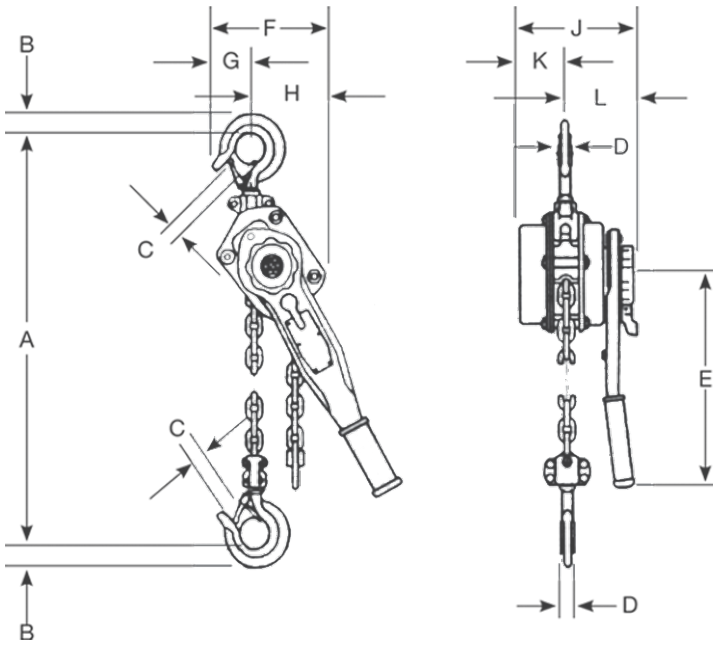

EQUIPPED WITH RFID TECHNOLOGY

All CM Bandit units for the U.S. market come standard with CM Smart ID™ – new radio frequency identification (RFID) technology from Columbus McKinnon. CM Smart ID can help simplify your inventory and inspection management processes.

Before the Bandit leaves our factory, a CM Smart ID RFID chip is associated with product information that is uploaded and stored on the CM Smart ID Cloud. This free information, which includes the Chip ID number, CM product code, product description and capacity, can be instantly accessed by anyone in your company, anywhere, at any time.



ACTUAL SIZE

SPECIFICATIONS

Model Number	Capacity Metric Rated Ton (kg)	Standard Lift ft. (m)	Lever Pull to Lift Rated Load lbs./ft. (kg)	Weight lbs. (kg)	Dimensions Inches (mm)										
					A	B	C	D	E	F	G	H	J	K	L
BAN07505	3/4 (750)	5 (1.52)	45 (20.41)	13.6 (6.17)	12.80 (325.12)	0.94 (23.88)	1.13 (28.70)	0.69 (17.53)	9.63 (244.60)	4.88 (123.95)	2.19 (55.63)	3.31 (84.07)	6.06 (153.92)	2.11 (53.59)	3.95 (100.33)
BAN07510		10 (3.05)		15.7 (7.12)											
BAN07515		15 (4.57)		18 (8.16)											
BAN07520		20 (6.1)		20.1 (9.12)											
BAN15005	1-1/2 (1500)	5 (1.52)	64 (29.03)	20.7 (9.39)	14.20 (360.68)	1.13 (28.70)	1.25 (31.75)	0.81 (20.57)	10.25 (260.35)	5.63 (143.00)	2.38 (60.45)	3.56 (90.42)	6.75 (171.45)	2.69 (68.33)	4.13 (104.90)
BAN15010		10 (3.05)		24.3 (11.02)											
BAN15015		15 (4.57)		27.9 (12.65)											
BAN15020		20 (6.1)		31.5 (14.29)											
BAN30005	3 (3000)	5 (1.52)	73 (33.11)	38.3 (17.37)	17.50 (444.5)	1.69 (42.93)	1.56 (39.62)	1.25 (31.75)	16.37 (415.8)	7.52 (191.01)	3.38 (85.85)	4.65 (118.11)	7.84 (199.14)	3.29 (83.57)	4.56 (115.82)
BAN30010		10 (3.05)		45.7 (20.73)											
BAN30015		15 (4.57)		53 (24.04)											
BAN30020		20 (6.1)		60.4 (27.4)											
BAN60005	6 (6000)	5 (1.52)	93 (42.18)	63.2 (28.67)	22.00 (558.8)	1.81 (45.97)	2.19 (55.63)	1.50 (38.1)	16.37 (415.8)	9.47 (240.54)	3.38 (85.85)	6.05 (153.67)	7.84 (199.14)	3.29 (83.57)	4.56 (115.82)
BAN60010		10 (3.05)		77.9 (35.33)											
BAN60015		15 (4.57)		92.6 (42.00)											
BAN60020		20 (6.1)		107.3 (48.7)											

Check for availability on 3 and 6 ton units.



THE WORLD'S FIRST HMI-CERTIFIED RATCHET LEVER HOIST

CM SERIES 622 HAND CHAIN HOIST

CAPACITIES

1000 lbs. to 10 tons

BENEFITS & FEATURES

- Simple, efficient, economical design.
- Compact design, low headroom and lightweight steel construction for easy installation, even in confined spaces.
- Weston-type load brake requires no lubrication.
- Hand wheel cover with guide slots minimizes jamming and slipping.
- Forged swivel hooks with latches reduce twisting of chain and unintentional unhooking of load when chain is slack.
- Standard hand chain drop is 2 feet less than lift (example: 8 ft. lift hoist has 6 ft. hand chain drop).
- One-year warranty.
- Metric rated.



CM SERIES 653 LEVER OPERATED HOIST

CAPACITIES

3/4 to 6 tons

BENEFITS & FEATURES

- Hardened steel load sharing gears.
- Double pawl arrangement for assured load control.
- Two chain guide rollers for positive chain engagement.
- Weston type braking system for positive load control and positioning.
- Simple one-handed, free chaining for fast load attachment.
- Hardened steel chain for strength and long wear life.
- Forged upper and lower hooks with heavy cast steel latches.
- 5-year warranty against defects in materials and workmanship.
- Meets ASME B30.21 – Manually Lever Operated Hoist Standard and European CE Standard.
- Metric rated.



CM SERIES 602/603 LEVER OPERATED HOISTS

CAPACITIES

500 lbs. & 1000 lbs.

BENEFITS & FEATURES

- Plated load chain is standard.
- Weston-type load brake.
- Rubber hand grip for better comfort and security.
- Lightweight design for ease of portability. Use in confined conditions with one-hand operation.
- Forged upper and lower hooks with latches standard.
- Impact resistant, all-steel frame, gear case and cover.
- Hardened link-type alloy steel load chain for strength and long wear.
- Free wheeling feature serves to quickly attach the load.
- Metric rated.



CM SHORT HANDLE PULLER

CAPACITIES

500 lbs. & 1000 lbs.

BENEFITS & FEATURES

- Easy one-hand operation.
- Lever pull range is 45 to 62 pounds to lift full load.
- Handle that rotates 360°, making it easy to operate in any position and in small spaces.
- Tough yet lightweight aluminum construction and powder coat finish.
- Hoist alloy hardened steel load chain for strength, long wear life and flexibility.
- Free chaining for fast, easy attachment to load.
- Forged upper and lower hooks with latches.
- Simple construction with fewer parts for ease of maintenance.
- Optional Load Limiter device protects against overload.
- Lifetime warranty.
- Made in U.S.A.



CM PLAIN & GEARED TROLLEYS

CAPACITIES

Rated loads from 500 lbs. to 5 tons in plain and geared models.

BENEFITS & FEATURES

ECONOMICAL

Excellent low cost choice for manual and powered hoists.

RUGGED

Designed to provide superior performance and long, efficient service.

LOW ROLLING EFFORT

Geared models have standard 6 ft. hand chain drop. Other hand chain drops available.

UNIVERSAL HANGING CLEVIS

Accepts most hook mounted hoists.

ADJUSTABLE

Trolley easily adjusts to fit any beam flange within range of adjustment, up to an 8.7" flange width.

WRAP-AROUND SIDE PLATES

Lugs provide additional security to increase operator safety and act as bumpers to protect wheels.

DUAL TREAD WHEELS

Will fit either tapered or flat beam flange within range of adjustment. Wheels include permanently lubricated, shielded ball bearings for long life and low maintenance.

LIFETIME WARRANTY



CM SERIES 632 CLOSE RADIUS TROLLEY

CAPACITIES

Rated loads from 500 lbs. to 3 tons. Negotiates radius curves as tight as 7" to 10"

BENEFITS & FEATURES

- Made of highest quality rolled steel.
- Unique double row, ball bearing wheel design for greater wear capacity.
- Larger V-bars available for wider flange adjustment.
- For low headroom applications.
- Permanently lubricated bearings.
- Exclusive Dial-Fit collar quickly adapts trolley to wide range of beams and patented rails.
- Dust covers shield and protect bearings.
- Trolleys available for larger beams, rails or tracks.
- Cast iron trolley guards available (except for 3 ton).
- Lifetime Warranty.



SCREWLOK BEAM CLAMP WITH SHACKLE

WORKING LOAD LIMIT

2,200 to 22,000 lbs.

Screwlok Beam Clamps are designed for attachment to the lower flanges of structural steel beams to provide a semi-permanent lifting point. The clamps can be quickly and easily attached via the screw-type mechanism.

BENEFITS & FEATURES

- Designed to fit flanges of most structural beams.
- Act as a semi-permanent lifting point for use with manual or electric hoists.
- Shackle incorporated for quick and easy component attachment.

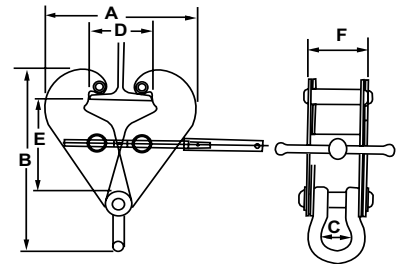

Product Code	Working Load Limit (lbs.)	Jaw Capacity (in.)	Dimensions (in.)						Weight (lbs.)
			A	B	C	D	E	F	
SC921	2,200	3 to 8-1/4	12.625	12.125	1.750	8.250	5.375	2.625	11.0
SC922	4,400	3 to 8-1/4	12.625	12.875	1.750	8.250	5.375	2.875	13.5
SC923	6,600	4 to 10-5/8	16.125	14.750	1.750	10.625	6.500	4.000	17.5
SC923/L	6,600	3 to 12	17.375	16.500	1.750	12.000	8.625	4.000	20.0
SC925	11,000	4 to 10-5/8	16.125	15.375	2.125	10.625	8.500	4.375	22.0
SC925/L	11,000	3 to 12	17.125	17.125	2.125	12.000	8.625	4.375	26.5
SC9210	22,000	3 to 12	18.125	20.000	3.250	12.000	8.625	4.375	35.5

BEAM CLAMP

CAPACITIES

Rated loads from 1 to 10 Ton

BENEFITS & FEATURES

- Reduced flange stress—Special clamp jaw design distributes load away from flange edge.
- Threaded mechanism fits securely on a wide range of flange widths and beam sizes.
- Low headroom provided by built-in suspension bar.
- Lifetime warranty



Capacity		Product Code	Model Number	I-Beam Width (in.)	Weight (lbs.)
(lbs.)	(ton)				
2,000	1	09001W	BC-1	3 to 9	9
4,000	2	09002W	BC-2	3 to 9	13
6,000	3	09003W	BC-3	3.2 to 12.6	18
10,000	5	09004W	BC-5	3.6 to 12.2	22
20,000	10	09005W	BC-10	3.6 to 12.6	34

TRANSPORTATION

Columbus McKinnon and our Tennessee-based Dixie Industries are leaders in innovation for the towing and transportation industries. We are the premier manufacturer of American-made chain and forged attachments for the towing industry. We are proud to not only offer towing products, but a full line of chain and hardware for the heavy-duty trucking industry.

LOAD BINDER USE, INSPECTION & CARE

USE

1. Always follow safe work practices and take precautions in use of binders. Particular attention is called to the following sections of D.O.T. Federal Motor Carrier Safety Regulations: S392.9 (relating to safe loading); S393.100 (relating to protection against shifting or falling cargo); and S393.102 (relating to securement systems).
2. Never exceed working load limit shown on the binder. Hand effort will tighten binder to working load limit.
3. Always inspect the load binder before use. See the load binder inspection section below.
4. Always position the load binder so the handle goes downward when securing or tightening the load.
5. Operate only by hand from a firm standing position.
6. Do not operate load binder while anyone is on the load.
7. Do not use a cheater bar or handle extension. Extensions can dangerously overload the binder system and may result in serious injury. Use a ratchet-type binder if sufficient leverage is difficult to develop.
8. Make certain that the lever of the lever-type binder is over center and locked. Always secure the handle in the locked position with a positive retaining method. The handle must be secured since there is a possibility of relaxation of the load, which may result in the lever moving from the locked-over-center position to relaxed mode, resulting in loss of tension in the system.
9. Release handle/load with extreme care. Make sure everyone is clear. Lever binder handle can snap back over center. Use open palm under handle and push up.
10. Tighten binders before moving and frequently recheck and retighten.

CARE

Care should be exercised during use so that the binder is not abused or damaged.

1. The binder or hooks should not be subjected to bending or sharp objects. Loading should be in a straight line.
2. Avoid exposure to corrosive mediums. Lubricate periodically.

INSPECTION

Inspect binder prior to each use for damage, distortion, cracks, nicks, or wear.

1. Bending of any feature in any plane of more than 10 degrees is cause for removal of the unit from service. Any distortion indicates overloading or misuse.
2. Distorted or elongated connecting links indicate overloading or misuse and is also cause for removal of the unit from service.
3. If wear of connecting link ends is more than 10% of the original stock, remove unit from service.
4. On lever-type binders inspect yoke periodically for distortion and make certain it is seated on the pins.
5. Deep nicks and gouges should be smoothed out to relief stress concentrations providing that the material removed does not exceed 10% of the total material.
6. If distortion, cracks, nicks, or wear affect more than 10% of the stock, discard the unit.

TIE-DOWN BINDER CHAIN USE

Depending on the type of cargo you are securing, there are a variety of different factors that can affect the way you secure the load.

WHEN SECURING CARGO, IT IS IMPORTANT TO CONSIDER THE FOLLOWING:

- What is the gross weight of the load?
- What is the physical size of the load?
- Is the weight uniformly distributed?
- Is the cargo size uniform?

THE EFFECT OF ANGLE ON INDIRECT TIEDOWNS

You also need to consider the effect that angles will have on indirect tie downs. The chart below demonstrates how the effectiveness of the tie down is impacted by the angle at which it is used.

TIEDOWN TIGHTENED TO 1,000 LBS. OF TENSION

Angle	Effectiveness	Downward or Clamping Force	
90	100%	1,000 lbs	
60	85%	850 lbs.	
45	70%	700 lbs.	
30	50%	500 lbs.	
15	25%	250 lbs.	



DETERMINING THE AGGREGATE WORKING LOAD LIMIT

When using multiple tie downs, you also need to determine the aggregate working load limit. **The aggregate working load limit of any securement system must be at least 50% of the weight of the cargo being secured with a length of less than 10 ft. (3 meters) & blocked from forward motion.** The diagram below illustrates how you would determine the aggregate working load limit when using multiple tie downs.

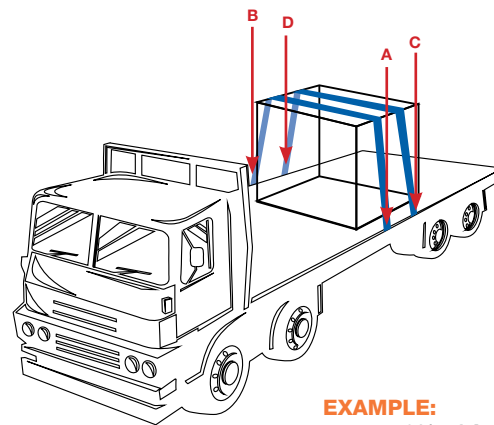

EXAMPLE:

- 50% of A
- + 50% of B
- + 50% of C
- + 50% of D

= Aggregate Working Load Limit

For full details on regulations and requirements for securing cargo, refer to FMCSA – Federal Motor Carrier Safety Administration Section(s) 393.100 through 393.136 of the FMCSA regulation handbook. Information is also available online at: <http://www.fmcsa.dot.gov>.

GENERAL BENEFITS & FEATURES OF CM HEAVY-DUTY TIE-DOWNS

- Meets FMCSA, CVSA tie-down requirements.
- Made from high quality alloy steel.
- Made in USA.
- Cannot be used for overhead lifting.
- Lighter weight than most transport binder chains.
- Does not degrade in ultra-violet light.
- Permanent identification on chain and attachments.
- Made to order assemblies available in 3 days or less.
- Design factor 4:1

CLEVIS STYLE HEAVY-DUTY TIE-DOWNS GRADE 80

WORKING LOAD LIMIT

4,500 to 12,000 lbs.

Chain Size (in.)	Chain Grade	Working Load Limit (lbs.)	Product Code	Length (L) (ft.)	Chain Finish	Weight (lbs.)
5/16	80	4,500	607031CV20	20	Black	19.60
5/16	80	4,500	607031CV25	25	Black	24.10
3/8	80	7,100	607037CV20	20	Black	30.30
3/8	80	7,100	607037CV25	25	Black	37.50
1/2	80	12,000	607050CV20	20	Black	54.60
1/2	80	12,000	607050CV25	25	Black	67.30

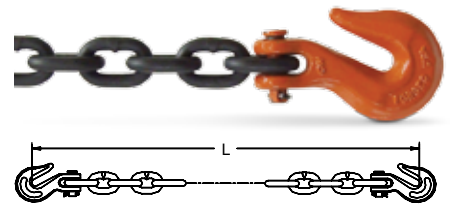

CLEVLOK® STYLE HEAVY-DUTY TIE-DOWNS GRADE 80 & 100

WORKING LOAD LIMIT

7,100 to 12,000 lbs.

Chain Size (in.)	Chain Grade	Working Load Limit (lbs.)	Product Code	Length (L) (ft.)	Chain Finish	Weight (lbs.)
3/8	80	7,100	607037CL20	20	Black	31.00
3/8	80	7,100	607037CL25	25	Black	38.00
1/2	80	12,000	607050CL15	15	Black	42.00
1/2	80	12,000	607050CL20	20	Black	55.00
3/8	100	8,800	607337CL20	20	Black	31.00
3/8	100	8,800	607337CL25	25	Black	38.50

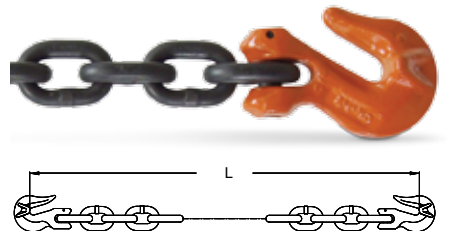

HEAVY DUTY RATCHET BINDERS GRADE 80 & 100

WORKING LOAD LIMIT

5,400 to 16,000 lbs.

With Chain Size (in.)	Use With Chain Grade	Working Load Limit (lbs.)	Product Code	End Fittings	Take Up (in.)	Weight (lbs.)
5/16	80	5,400	48365	Hook & Hook	8	12
3/8	80	7,100	48360	Hook & Hook	8	13
3/8	80 or 100	9,200	48366	Hook & Hook	8	13
1/2	80	13,000	48367	Hook & Hook	8	16
1/2	80 or 100	15,000	48358	Hook & Hook	8	16
1/2	80 or 100	16,000	48387	Hook & Hook	8	16



TRANSPORT (BINDING) CHAIN GRADE 70

STANDARD & SHORT LINK

WORKING LOAD LIMIT

3,150 to 11,300 lbs.

BENEFITS & FEATURES

- Do not use for overhead lifting.
- High-carbon steel, heat treated.
- Zinc plated with gold chromate finish.
- Meets ASTM & NACM standards.
- Meets FMCSA & CVSA requirements.
- Thermal heat treated using advanced technology.
- Heat treated for superior wear and toughness.
- 100% proof tested.
- Permanent identification on chain.
(embossed with G70, plus 3 letter trace code)
- Full weld trim.
- Design factor 4:1

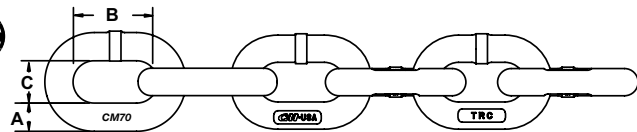

Chain Size (in.)	Working Load Limit (lbs.)	Nominal Chain Dimensions (in.)			Per Foot			Per Drum				Per Pail	
		Material Diameter A	Inside Length B	Inside Width C	Product Code	Weight (lbs./ft.)	Approximate Number of Links (per ft.)	Full Drum		Half Drum		Product Code	Length (ft.)
								Product Code	Length (ft.)	Product Code	Length (ft.)		
1/4	3,150	0.28	0.84	0.47	608927	0.76	14.30	678531	800	678521	400	678517	130
5/16	4,700	0.33	0.98	0.46	608935	1.01	12.20	678532	550	678522	275	678518	90
5/16**	4,700	0.33	1.10	0.50	609035	0.97	10.90	679032	550	679022	275	679018	90
3/8	6,600	0.39	1.14	0.54	608941	1.46	10.50	678533	400	678523	200	678519	60
3/8**	6,600	0.39	1.38	0.60	609041	1.37	8.73	679033	400	679023	200	679019	60
1/2	11,300	0.53	1.56	0.73	608954	2.70	7.70	678535	200	678525	100	-	-

** Standard Link Grade 70 Chain



WELDED ASSEMBLY GRADE 70

WORKING LOAD LIMIT

4,700 to 6,600 lbs.

BENEFITS & FEATURES

- Meets FMCSA, CVSA, DOT requirements.
- Available in custom-built lengths.
- Assemblies are available with your choice of mechanical or welded end attachments.
- Welded assemblies are proof tested after welding.
- Full line of lever and ratchet binders to accommodate binder chain offering.
- Gold Chromate per ASTM B633 Fe/ZN 13 Type II.
- Design factor 4:1

Chain Size (in.)	Working Load Limit (lbs.)	Length (L) (ft.)	Product Code	Product Code in Bag	Weight (lbs.)
Short Link					
5/16	4,700	14	–	638259	15.19
5/16	4,700	16	–	638264	17.20
5/16	4,700	20	638224	–	21.22
5/16	4,700	20	–	638302	21.22
5/16	4,700	25	638260	–	26.24
5/16	4,700	25	–	638306	26.24
3/8	6,600	20	638558	–	31.06
Standard Link					
5/16	4,700	16	639064	–	16.64
5/16	4,700	16	–	639064BG	16.64
5/16	4,700	20	639024	–	20.52
5/16	4,700	20	–	639024BG	20.52
5/16	4,700	25	639060	–	25.36
3/8	6,600	16	639089	–	23.75
3/8	6,600	20	639058	–	29.31

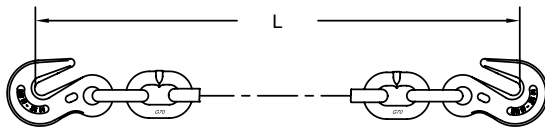

CLEVIS ASSEMBLY GRADE 70

WORKING LOAD LIMIT

3,150 to 11,300 lbs.

BENEFITS & FEATURES

- Hook on each end.
- Meets all Department of Transportation (D.O.T.) requirements and is required in most states by the D.O.T.
- Chain won't degrade in ultra-violet light, as compared to nylon straps.
- Custom lengths available.
- Gold Chromate per ASTM B633 Fe/ZN 13 Type II
- Design factor 4:1

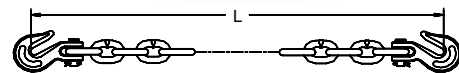

Chain Size (in.)	Working Load Limit (lbs.)	Product Code	Product Code in Bag	L (ft.)	Weight (lbs.)
Short Link					
1/4	3,150	638265	-	20	16.41
5/16	4,700	638274	-	12	13.10
5/16	4,700	638282	638277	16	17.10
5/16	4,700	638283	-	18	19.12
5/16	4,700	638284	638266	20	21.13
5/16	4,700	638313	-	24	25.15
5/16	4,700	638279	638279BG	25	26.16
3/8	6,600	638291	-	14	22.23
3/8	6,600	638292	638268	16	25.19
3/8	6,600	638293	-	18	28.15
3/8	6,600	638294	638267	20	31.11
1/2	11,300	638350	-	20	56.93
Standard Link					
5/16	4,700	639082	-	16	15.60
5/16	4,700	639084	639084BG	20	20.40
5/16	4,700	639079	-	25	25.30
3/8	6,600	639091	-	14	21.00
3/8	6,600	639092	-	16	23.80
3/8	6,600	639093	-	18	26.60
3/8	6,600	639094	639094BG	20	31.16
3/8	6,600	639097	-	25	36.30

RIVET ASSEMBLY GRADE 70

WORKING LOAD LIMIT

4,700 to 6,600 lbs.

BENEFITS & FEATURES

- Riveted hooks prevent loss or theft of hooks.
- Gold Chromate per ASTM B633 Fe/ZN 13 Type II
- Design factor 4:1

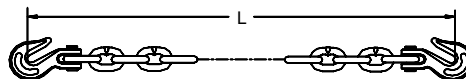

Chain Size (in.)	Working Load Limit (lbs.)	Product Code	L (ft.)	Weight (lbs.)
Short Link				
5/16	4,700	638281CRV	14	15.10
5/16	4,700	638282CRV	16	17.10
5/16	4,700	638283CRV	18	19.10
5/16	4,700	638284CRV	20	21.10
3/8	6,600	638291CRV	14	22.22
3/8	6,600	638292CRV	16	25.18
3/8	6,600	638293CRV	18	28.14
3/8	6,600	638294CRV	20	31.10
Standard Link				
5/16	4,700	639084CRV	20	20.43
5/16	4,700	639079CRV	25	25.27
3/8	6,600	639094CRV	20	29.33

CLEVIS SLIP HOOK GRADE 70

WORKING LOAD LIMIT

4,700 to 6,600 lbs.

BENEFITS & FEATURES

- Designed specifically for transport Grade 70 chain.
- 4:1 design factor.
- Hook embossed with trace code providing traceability throughout the manufacturing and testing process to heat of steel.
- Durable orange powder coated finish.

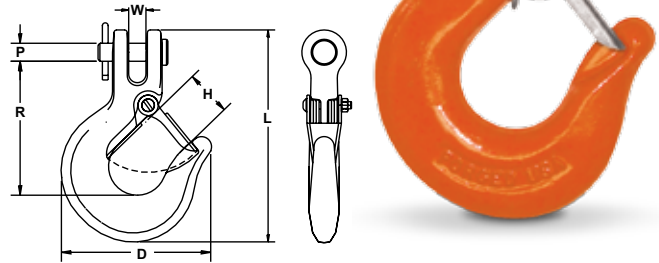

Size (in.)	Working Load Limit (lbs.)		Finish	Standard Package	With Latch		Without Latch		Latch Kit	Dimensions (in.)					
	Grade 63	Grade 70			Product Code	Weight (lbs.)	Product Code	Weight (lbs.)		Product Code	W	D	H	L	R
1/4	2,750	–	Orange Paint	20	–	–	M904A	.50	–	0.32	2.63	0.94	3.67	2.31	0.33
5/16	3,600	4,700	Orange Paint	20	6905AWL	.96	M6905A	.91	4X1304	0.36	3.27	1.06	4.62	2.89	0.38
5/16	3,600	4,700	Yellow Chromate	20	6905AZL	.96	M6905AZ	.91	4X1304	0.36	3.27	1.06	4.62	2.89	0.38
3/8	5,500	6,600	Orange Paint	20	6906AWL	1.66	M6906A	1.61	4X1305	0.45	3.87	1.00	5.42	3.39	0.49
3/8	5,500	6,600	Yellow Chromate	20	6906AZL	1.66	M6906AZ	1.61	4X1305	0.45	3.87	1.00	5.42	3.39	0.49
5/16	3,600	–	Orange Paint	20	–	–	M905A	.75	–	0.38	3.18	1.06	4.27	2.54	0.38
3/8	5,500	–	Orange Paint	20	–	–	M906A	1.25	–	0.45	3.66	1.25	4.88	3.02	0.49
7/16	6,900	–	Orange Paint	10	–	–	M907A	2.00	–	0.50	4.31	1.56	5.69	3.48	0.50
1/2	9,400	–	Orange Paint	10	–	–	M908A	2.80	–	0.59	4.88	1.75	6.41	4.00	0.59
5/8	14,200	–	Orange Paint	5	–	–	M910A	5.00	–	0.81	5.69	2.00	7.56	4.75	0.75

EYE SLIP HOOK GRADE 70

WORKING LOAD LIMIT

3,150 to 8,750 lbs.

BENEFITS & FEATURES

- Designed specifically for transport Grade 70 chain.
- 4:1 design factor.
- Hook embossed with trace code providing traceability throughout the manufacturing and testing process to heat of steel.
- Durable orange powder coated finish.

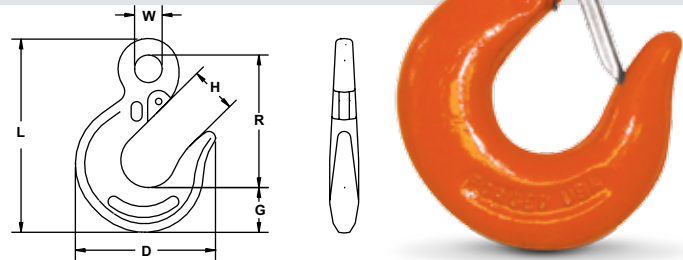

Size (in.)	Working Load Limit (lbs.)		Standard Package	Product Code			Dimensions (in.)						Weight (lbs.)
	Grade 63	Grade 70		With Latch	Without Latch	Latch Kit	W	D	H	L	R	G	
1/4	2,750	3,150	20	M6304WL	M6304	4X1302	0.55	2.69	0.87	3.80	2.62	0.87	0.45
5/16	3,600	4,700	20	M6305WL	M6305	4X405	0.63	3.18	1.01	4.41	3.01	1.03	0.58
3/8	5,500	6,600	20	M6306WL	M6306	4X406	0.80	3.74	1.17	5.38	3.73	1.25	1.40
7/16	7,100	8,750	10	M6307WL	M6307	4X410	0.83	4.34	1.42	5.79	3.93	1.38	1.50
1/2	9,400	–	10	–	M308A	–	0.95	4.94	1.76	6.33	4.31	1.50	2.30
5/8	14,200	–	5	–	M310A	–	1.19	5.63	2.00	7.67	5.29	1.69	3.77

CLEVIS GRAB HOOK GRADE 70

WORKING LOAD LIMIT

4,700 to 6,600 lbs.

BENEFITS & FEATURES

- Designed specifically for transport Grade 70 chain.
- 4:1 design factor.
- Yellow chromate finish.
- Not recommended for overhead lifting.



Size (in.)	Working Load Limit (lbs.)	Standard Package	Product Code (Yellow Chromate)	Dimensions (in.)						Weight (lbs.)
				W	D	H	L	R	P	
5/16	4,700	10	62273	0.42	2.40	0.44	3.52	2.18	0.38	0.75
3/8	6,600	10	62373	0.52	2.94	0.54	4.17	2.53	0.44	1.10

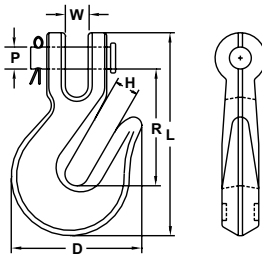

EYE GRAB HOOK GRADE 70

WORKING LOAD LIMIT

4,700 to 6,600 lbs.

BENEFITS & FEATURES

- Designed specifically for transport Grade 70 chain.
- 4:1 design factor.
- Self-colored finish.
- Not recommended for overhead lifting.



Size (in.)	Working Load Limit (lbs.)	Standard Package	Product Code (Self-Colored)	Dimensions (in.)						Weight (lbs.)
				W	D	H	L	R	P	
5/16	4,700	50	71297	0.70	2.39	0.49	3.69	2.42	1.15	0.75
3/8	6,600	25	71397	0.67	2.65	0.51	3.73	2.45	1.16	1.10

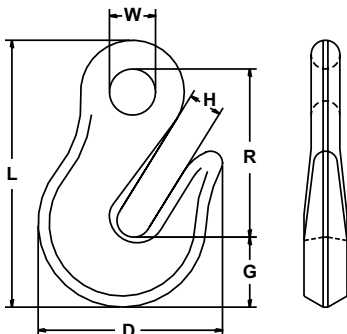

LOAD BINDER OPERATING INSTRUCTIONS

- Follow D.O.T. Federal Motor Carrier Safety Regulations S 392.9, S 393.100, and S 393.102.
- Inspect before use. Replace worn and deformed binders. Lubricate pivot and swivel points for optimum performance.
- Do not operate with anyone on load.
- Always apply lever binder in straight line hook to hook manner without bending and such that handle goes down when securing load.
- Tighten binders before moving and recheck frequently.
- Do not exceed working load limit shown on binder—hand effort will tighten binder to working load limit.
- Do not use cheater bar or handle extension as their use can overload binder system and result in injury.
- Secure handle down with a positive retaining method.
- Release handle/load with extreme care. Make sure everyone is clear. Lever binder handle can snap back over center. Use open palm under handle and push up.

FORGED LEVER LOAD BINDER GRADES 30, 43, 70, 80

WORKING LOAD LIMIT

2,600 to 9,200 lbs.

BENEFITS & FEATURES

- All components are forged, not cast.
- Forged binders are lighter and stronger than cast binders.
- Under equal force a forged handle will yield and bend while a cast handle may break.
- Design factor 4:1



Chain Grade & Size (in.)				Product Code	Working Load Limit (lbs.)	Handle Take Up (in.)	Handle Length (in.)	Weight (lbs.)
G30	G43	G70	G80					
1/4	1/4	–	–	48304	2,600	3.75	11.25	3.0
3/8	3/8	5/16	–	48305	5,400	4.50	16.12	8.1
1/2	1/2	3/8	–	48306	9,200	4.75	16.62	10.6
3/8	3/8	3/8	3/8	48769	7,100	4.50	16.62	8.1

CLAW HOOK LOAD BINDER GRADES 43, 70

WORKING LOAD LIMIT

5,400 to 6,600 lbs.

Chain Grade & Size (in.)		Product Code	Working Load Limit (lbs.)	Handle Take Up (in.)	Working Load Limit Length (in.)	Weight (lbs.)
G30	G70					
3/8	5/16	Special Order	5,400	4.50	16.12	0.69
–	3/8	Special Order	9,200	4.75	16.62	1.00
3/8	3/8	Special Order	7,100	4.50	16.62	2.02



RATCHET BINDER FEATURES

- Rugged Handle – our ratchet handle purposely has an open design using self-locking one-way bolts. The open allows mud, snow, ice or other clogging substance to be easily removed from the ratchet mechanism by striking with a hammer or other tool, even at below freezing temperatures.
- Extra Strong Eye Bolts – All 1" ratchet binders feature oversized eyebolts and barrels providing additional support material for wear and tear.
- Gears – Dixie ratchet gears are permanently welded to the barrel—there is no roll pin to fall out.
- Barrels – Dixie Industries upset forges our barrels which builds mass for deeper and more consistent threads that will not pull out. This provides constant contact for the Acme Threads between bolt and barrel.
- Acme Threads – fastest take up, stays put and won't back off. Some other companies use tapered threads.
- Micro-Alloy Hooks – designed to yield before catastrophic failure.

FORGED RATCHET LOAD BINDER GRADES 30, 43, 70, 80, 100

WORKING LOAD LIMIT

2,600 to 16,000 lbs.

BENEFITS & FEATURES

- Handle is designed loose using self-locking, one-way bolts allowing easy removal of unwanted debris such as mud, snow or ice.
- Proof tested to 50% of the minimum breaking strength.
- Gears are permanently welded to the barrel.
- Durable powder coated finish.
- Design factor 4:1 (Except 48358 & 48387, which are 3:1)



Chain Grade & Size (in.)					Product Code	End Fittings	Standard Package	Working Load Limit (lbs.)	Take Up (in.)	Handle Length (in.)	Barrel Size O.D. (Diam. x Length) (in.)	Screw Diameter (in.)	Weight (lbs.)
G30	G43	G70	G80	G100									
3/16 & 1/4	1/4	–	–	–	48364	Hook / Hook	4	2,600	4	12	1-5/16 x 6	5/8	5.4
–	–	–	–	–	48811	Eye / Eye (no hook)	4	5,400	8.5	12	1-5/16 x 10	3/4	8.6
–	–	–	–	–	48363	Eye / Eye (no hook)	4	13,000	8	14	1-1/2 x 10	1	9.8
5/16 & 3/8	5/16 & 3/8	5/16	–	–	46565	Body Only	4	5,400	8	–	1-1/2 x 10	1	11.0
3/8 & 1/2	3/8 & 1/2	3/8	–	–	46566	Body Only	4	9,200	8	–	1-1/2 x 10	1	11.7
–	–	–	–	–	46565H	Handle Only	4	–	–	14	–	–	4.3
5/16 & 3/8	5/16 & 3/8	5/16	–	–	48810	Hook / Hook	4	5,400	8.5	12	1-5/16 x 10	3/4	8.6
5/16 & 3/8	5/16 & 3/8	5/16 & 3/8	5/16 & 3/8	–	48360	Hook / Hook	4	7,100	8	14	1-1/2 x 10	1	13.0
5/16 & 3/8	5/16 & 3/8	5/16	5/16	–	48365	Hook / Hook	4	5,400	8	14	1-1/2 x 10	1	12.0
3/8 & 1/2	3/8 & 1/2	3/8	3/8	–	48366	Hook / Hook	4	9,200	8	14	1-1/2 x 10	1	13.0
1/2 & 5/8	1/2 & 5/8	1/2	1/2	–	48367	Hook / Hook	4	13,000	8	14	1-1/2 x 10	1	16.0
–	3/8 & 1/2	3/8 & 1/2	3/8 & 1/2	3/8	48458	Hook / Hook	4	12,000	8	14	1-1/2 x 10	1	13.0
–	5/16 & 3/8	5/16 & 3/8	5/16 & 3/8	5/16 & 3/8	48455	Hook / Hook	4	8,800	8	14	1-1/2 x 10	1	16.0
3/8 & 1/2	3/8 & 1/2	3/8 & 1/2	3/8 & 1/2	3/8 & 1/2	48358	Hook / Hook	4	15,000	8	14	1-1/2 X 10	1	16.0
3/8 & 1/2	3/8 & 1/2	3/8 & 1/2	3/8 & 1/2	3/8 & 1/2	48387	Hook / Hook	4	16,000	8	14	1-1/2 X 10	1	16.0

TIGHTENER LOAD BINDER

WORKING LOAD LIMIT

375 lbs.

BENEFITS & FEATURES

- Features a swivel hook for easier operation.
- Either hook may be permanently attached to chain.
- Rugged cast construction with formed hooks.



Product Code	Working Load Limit (lbs.)	Handle Take Up (in.)	Handle Length (in.)	Weight (lbs.)
48949	375	3.00	9.50	1.40

SPECIALTY FORGED LEVER LOAD BINDER GRADES 30, 43, 70

WORKING LOAD LIMIT

5,400 lbs.

BENEFITS & FEATURES

- Durable powder coated finish, design factor 4:1
- DIXI-LOC BINDERS provide extra security by allowing the binder to be locked in closed position using a pad lock, linchpin or bolt.
- COMPRESSION BINDERS are designed for securing bar and rod steel, lumber, poles and machinery with rubber tires.
- EZ GRAB BINDERS are military style binders designed to use handle leverage to remove slack from the chain before hook-up, achieving correct tension on the first try.



Compression Binders

Binder Type	Description	Chain Grade & Size (in.)			Product Code	Standard Package	Working Load Limit (lbs.)	Take Up (in.)	Handle Length (in.)	Weight (lbs.)
		G30	G43	G70						
Dixi-Loc Binder	Lockable	3/8	3/8	5/16	48385	4	5,400	4.50	16.62	8.50
Compression Binder	Metal Spring	3/8	3/8	5/16	48395	4	5,400	4.50	16.62	14.60
EZ Grab Binder	Lever	3/8	3/8	5/16	48325	4	5,400	4.50	18.38	8.75

REMOVABLE HANDLE LOAD BINDER GRADES 30, 43, 70

WORKING LOAD LIMIT

5,400 to 9,200 lbs.

BENEFITS & FEATURES

- Removable handle provides greater load security by making it less likely for load to be stolen.
- Reduces overall weight.
- Durable powder coated finish.
- Design factor 4:1

Size (in.)			Product Code	Standard Package	Working Load Limit (lbs.)	Handle Take Up (in.)	Handle Length (in.)	Weight (lbs.)	
G30	G43	G70							
3/8	3/8	5/16	46565	Body	4	5,400	8.00	–	7.4
1/2	1/2	3/8	46566	Body	4	9,200	8.00	–	11.7
–	–	–	46565H	Handle	4	–	–	14	4.3

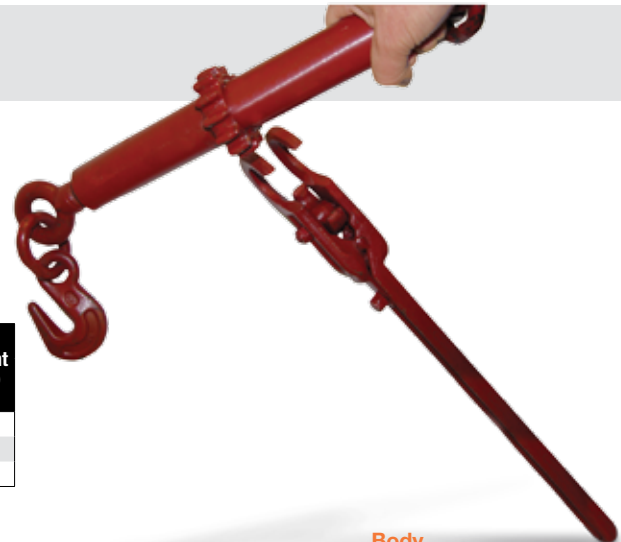



SIXTH WHEEL RATCHET

BENEFITS & FEATURES

- Ergonomically reduces risk of injury when operating trailer landing gear.
- Permits the operator to use an ergonomically-correct posture, utilizing body weight while reducing muscle exertion.
- Preferred by 80% of drivers in actual use tests.
- US Patent 7,021,659 stamped on all authentic Sixth Wheel units.
- Designed to fit all standard gear.
- Secured by a self-locking security pin and cap made of hardened steel that can only be removed by using heavy-duty shop equipment.
- Design factor 5:1

Product Code	Diameter (in.)	Length (A) (in.)
34902R082P	1	8
34902R132P	1	13
34902R202P	1	20



SIXTH WHEEL
 RATCHET

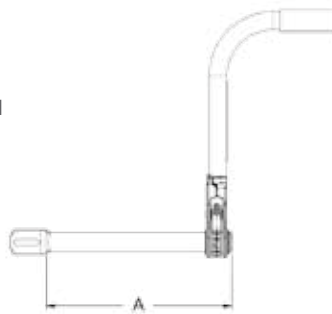

THE SIXTH WHEEL VS. STANDARD CRANK

THE SIXTH WHEEL

Utilizes a ratcheting mechanism that allows the operator to exert more force while avoiding awkward and unsafe postures.



STANDARD CRANK

Requires a full-circle motion. This puts the operator in unsafe postures while exerting extremely high forces.





TRAINING

DESIGNED SPECIFICALLY FOR THE ENTERTAINMENT INDUSTRY

GET TRAINED. CORE CLASSES

CM-ET offers training programs that cover everything from hoist design and operation to maintenance and tips of the trade. Students become well-versed in all aspects of hoist technology and practices related to safe operation and repair, including:

- Basic Lodestar Introduction & Maintenance
- Entertainment Rigging
- Rigging Hoist Technician Certification
- Road Hoist Technician Certification
- Truss Safety & Standards
- Motor Technician Certification

GET INTENSE. CM-ET MEGA SCHOOL

We bring together various industry experts for a one-of-a-kind training program. This intense 5-day course will take your skill set to higher level.

CAN'T GET AWAY? TRAIN ONLINE. ONLINE LODESTAR MAINTENANCE TRAINING

For over 30 years, CM-ET has offered the Lodestar Motor School maintenance class to help familiarize entertainment technicians and riggers on safe and proper maintenance.

This popular class is now available online!

Students can expect the same level of education they would get if they attended one of our hands-on classes. Get trained online at learn at your pace and on your schedule.

Visit www.cmcodepot.com for a complete list of entertainment training classes.



USA: 800.888.0985 • +1.716.689.5400 • Fax: 716.689.5644

CDN: 877.264.6478 • Fax: 877.264.6477

www.cm-et.com

