

CROSS-OVER LADDER - COL-3-26-23-HDG

APPROX WEIGHT: 290.19 lbs.
DOES NOT INCLUDE WEIGHT OF POWER OR PACKAGING!!!

*** ANY ADDITIONS, DELETIONS, OR OMISSIONS MUST BE CORRECTED ON THIS DRAWING AS THIS DRAWING WILL BE CONSIDERED ALL INCLUSIVE ***

ALL GRAPHICS PROVIDED ARE FOR REFERENCE ONLY. IF CERTAIN DIMENSIONS ARE CRITICAL PLEASE VERIFY THOSE DIMENSIONS WITH YOUR SALESPERSON

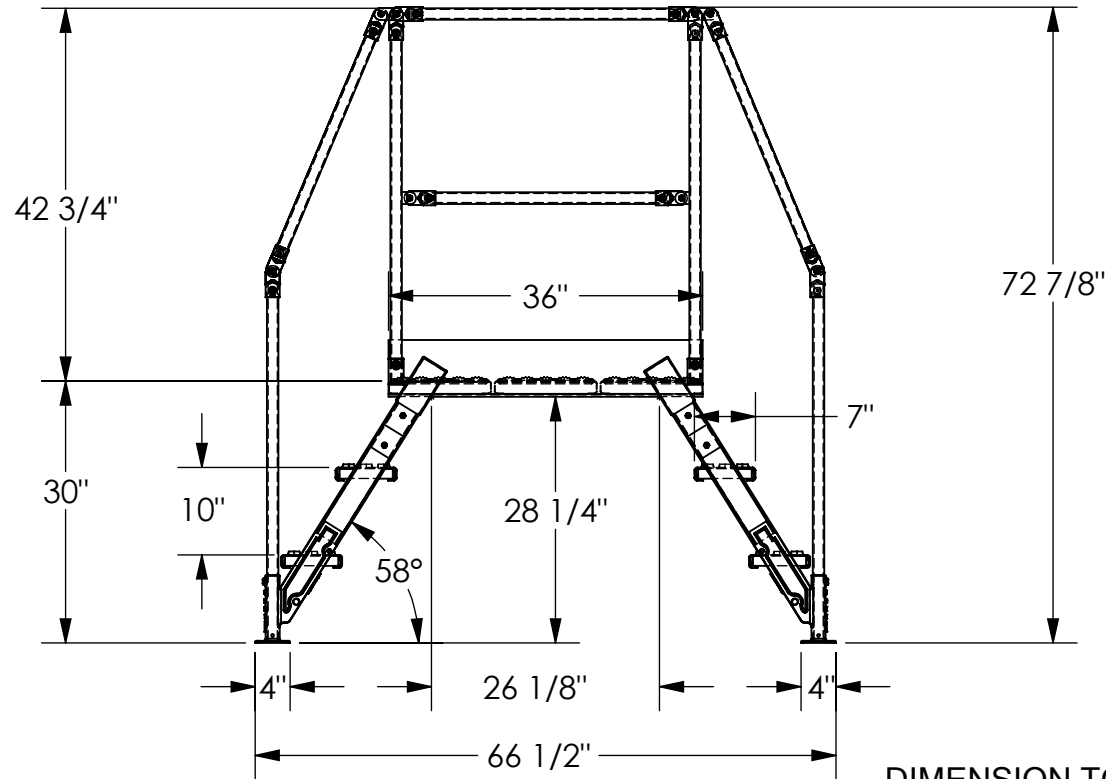
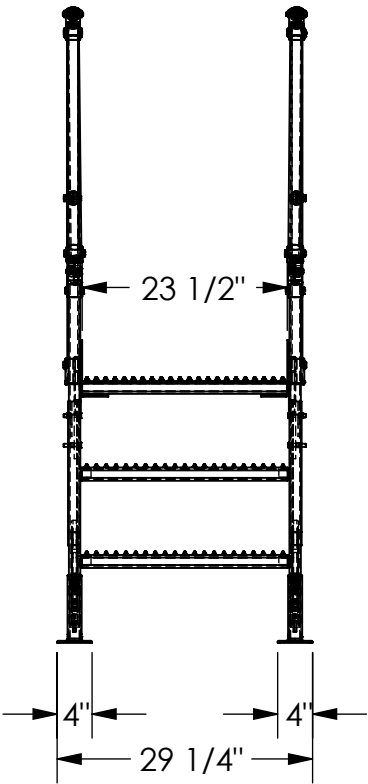

DIMENSION TOLERANCE ± 1/4"

STANDARD FEATURES

MODEL NUMBER: COL-3-26-23-HDG
 OVERALL SIZE:
 29 1/4" W x 66 1/2" L x 72 7/8" H
 CLEARANCE SPAN:
 26 1/8" W x 28 1/4" H
 TOP PLATFORM HEIGHT: 30"
 STEP HEIGHT SPACING: 10"
 STEP DEPTH: 7"
 STEP & PLATFORM WIDTH 23 1/2"
 CLIMB ANGLE: 58°
 HOT DIPPED GALVANIZED FINISH
 HANDRAILS ARE TOUGH BAKED IN POWDER COATED YELLOW FINISH
 ALL STEPS & PLATFORM ARE SERRATED STEEL
 KNOCK-DOWN HANDRAILING
 (UNIT SHIPS KNOCKED DOWN, ASSEMBLY REQUIRED)

SPECIAL FEATURES

NONE

NOTE

UNIT MUST BE ANCHORED TO THE FLOOR!!!
 Ø7/16" MOUNTING HOLES
 8 TOTAL MOUNTING HOLES PER
 STANDARD UNIT
 2 MOUNTING HOLES PER CORNER BRACKET

APPROVAL

I, THE UNDERSIGNED, AGREE THAT THE PRODUCT AS REPRESENTED SATISFIES DESIGN AND DIMENSION REQUIREMENTS. I ALSO ACKNOWLEDGE MY DUTY TO CONFIRM PRODUCT AND INSTALLATION COMPLIANCE WITH ALL APPLICABLE FEDERAL, STATE AND LOCAL REGULATIONS AND STANDARDS.

UNITS REQUIRING APPROVAL DRAWINGS OR MODIFIED ARE NON-RETURNABLE

[] As drawn [] As marked

Signed: _____ Date: _____

Printed Name: _____

LEAD TIME WILL START UPON RECEIPT OF SIGNED APPROVAL DRAWING

DISTRIBUTOR'S NAME:		P.O.#
VESTIL MANUFACTURING		X
DRAWN BY: BCN		DATE: 4/29/2016
REFERENCE: X		SCALE: 1:22
QUOTED LEAD TIME: X		QUOTE # X
		SALES: X
		FILE NAME: 44-007-729