

CROSS-OVER LADDER - COL-4-36-14

APPROX WEIGHT: 292.99 lbs.
DOES NOT INCLUDE WEIGHT OF POWER OR PACKAGING!!!

*** ANY ADDITIONS, DELETIONS, OR OMISSIONS MUST BE CORRECTED ON THIS DRAWING AS THIS DRAWING WILL BE CONSIDERED ALL INCLUSIVE ***

ALL GRAPHICS PROVIDED ARE FOR REFERENCE ONLY. IF CERTAIN DIMENSIONS ARE CRITICAL PLEASE VERIFY THOSE DIMENSIONS WITH YOUR SALESPERSON

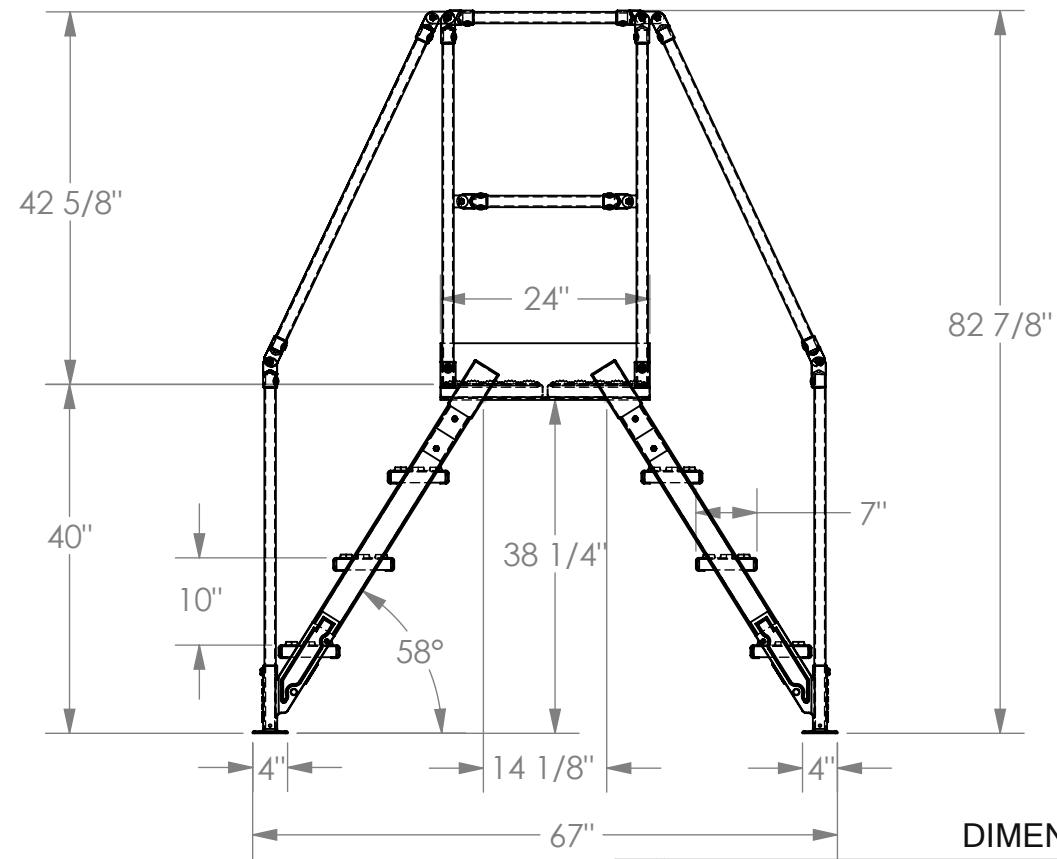
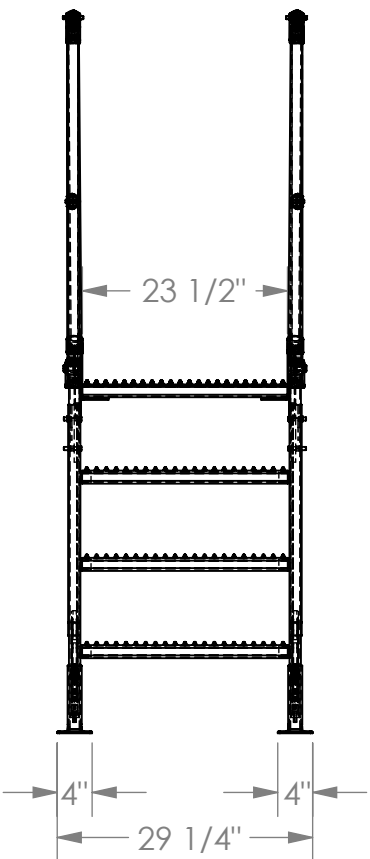

DIMENSION TOLERANCE $\pm 1/4$ "

STANDARD FEATURES

- MODEL NUMBER: COL-4-36-14
- OVERALL SIZE:
29 1/4" W x 67" L x 82 7/8" H
- CLEARANCE SPAN:
14 1/8" W x 38 1/4" H
- TOP PLATFORM HEIGHT: 40"
- STEP HEIGHT SPACING: 10"
- STEP DEPTH: 7"
- STEP & PLATFORM WIDTH 23 1/2"
- CLIMB ANGLE: 58°
- ALL STEPS & PLATFORM ARE SERRATED STEEL
- KNOCK-DOWN HANDRAILING (UNIT SHIPS KNOCKED DOWN, ASSEMBLY REQUIRED)

SPECIAL FEATURES

NONE

NOTE

- UNIT MUST BE ANCHORED TO THE FLOOR!!!
- Ø7/16" MOUNTING HOLES
- 8 TOTAL MOUNTING HOLES PER STANDARD UNIT
- 2 MOUNTING HOLES PER CORNER BRACKET

FOR INTERNAL USE ONLY PROJECT SIGN OFF	
SALES	
ENG.	
FAB.	
POWER	

APPROVAL

I, THE UNDERSIGNED, AGREE THAT THE PRODUCT AS REPRESENTED SATISFIES DESIGN AND DIMENSION REQUIREMENTS. I ALSO ACKNOWLEDGE MY DUTY TO CONFIRM PRODUCT AND INSTALLATION COMPLIANCE WITH ALL APPLICABLE FEDERAL, STATE AND LOCAL REGULATIONS AND STANDARDS.

ANY MODIFIED UNITS ARE NON-RETURNABLE

[] As drawn [] As marked

Signed: _____ Date: _____

Printed Name: _____

LEAD TIME WILL START UPON RECEIPT OF SIGNED APPROVAL DRAWING

DISTRIBUTOR'S NAME:		P.O.#
VESTIL MANUFACTURING		X
DRAWN BY: BCN	DATE: 4/29/2016	W.O.#
REFERENCE: X	SCALE: 1:22	X
QUOTED LEAD TIME: X	QUOTE #	SALES: X
	X	FILE NAME:
		44-007-063