

# CROSS-OVER LADDER - COL-5-46-14-HDG

APPROX WEIGHT: 324.46 lbs.  
 DOES NOT INCLUDE WEIGHT OF POWER OR PACKAGING!!!

\*\*\* ANY ADDITIONS, DELETIONS, OR OMISSIONS MUST BE CORRECTED ON THIS DRAWING AS THIS DRAWING WILL BE CONSIDERED ALL INCLUSIVE \*\*\*

ALL GRAPHICS PROVIDED ARE FOR REFERENCE ONLY. IF CERTAIN DIMENSIONS ARE CRITICAL PLEASE VERIFY THOSE DIMENSIONS WITH YOUR SALESPERSON

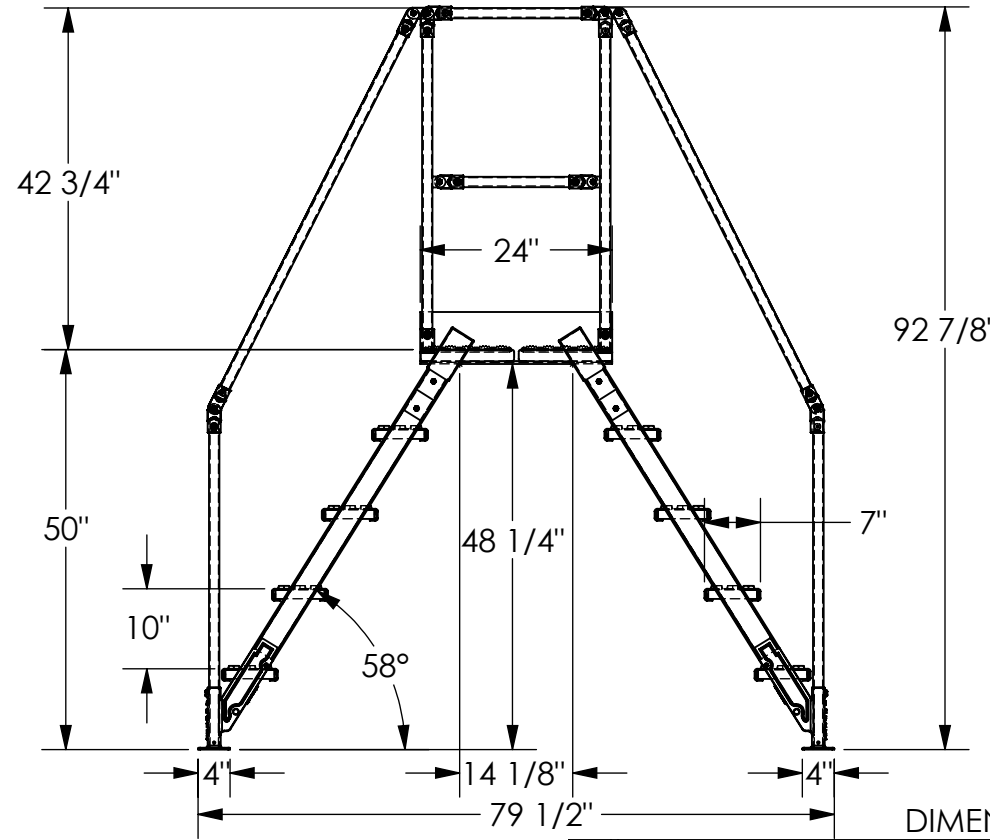
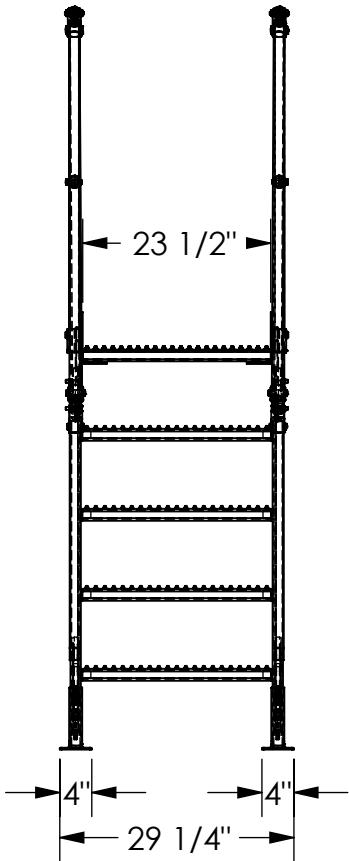

DIMENSION TOLERANCE  $\pm 1/4$ "

## STANDARD FEATURES

MODEL NUMBER: COL-5-46-14-HDG  
 OVERALL SIZE:

29 1/4" W x 79 1/2" L x 92 7/8" H  
 CLEARANCE SPAN:

14 1/8" W x 48 1/4" H

TOP PLATFORM HEIGHT: 50"

STEP HEIGHT SPACING: 10"

STEP DEPTH: 7"

STEP & PLATFORM WIDTH 23 1/2"

CLIMB ANGLE: 58°

HOT DIPPED GALVANIZED FINISH

HANDRAILS ARE TOUGH BAKED IN POWDER COATED YELLOW FINISH

ALL STEPS & PLATFORM ARE SERRATED STEEL

KNOCK-DOWN HANDRAILING

(UNIT SHIPS KNOCKED DOWN, ASSEMBLY REQUIRED)

## SPECIAL FEATURES

NONE

## NOTE

UNIT MUST BE ANCHORED TO THE FLOOR!!!

Ø7/16" MOUNTING HOLES

8 TOTAL MOUNTING HOLES PER  
 STANDARD UNIT

2 MOUNTING HOLES PER CORNER  
 BRACKET

APPROVAL

I, THE UNDERSIGNED, AGREE THAT THE PRODUCT AS REPRESENTED SATISFIES DESIGN AND DIMENSION REQUIREMENTS. I ALSO ACKNOWLEDGE MY DUTY TO CONFIRM PRODUCT AND INSTALLATION COMPLIANCE WITH ALL APPLICABLE FEDERAL, STATE AND LOCAL REGULATIONS AND STANDARDS.

**UNITS REQUIRING APPROVAL DRAWINGS OR MODIFIED ARE NON-RETURNABLE**

As drawn       As marked

Signed: \_\_\_\_\_ Date: \_\_\_\_\_

Printed Name: \_\_\_\_\_

LEAD TIME WILL START UPON RECEIPT OF SIGNED APPROVAL DRAWING

DISTRIBUTOR'S NAME:		P.O.#
VESTIL MANUFACTURING		X
DRAWN BY: BCN	DATE: 4/29/2016	W.O.#
REFERENCE: X	SCALE: 1:24	X
QUOTED LEAD TIME: X	QUOTE #	FILE NAME:
	X	44-007-736