

# THREE STEP, ALUMINUM, CROSS OVER - COL-AL-3-26-33

APPROX WEIGHT: 154.73 lbs.  
DOES NOT INCLUDE WEIGHT OF POWER OR PACKAGING!!!

\*\*\* ANY ADDITIONS, DELETIONS, OR OMISSIONS MUST BE CORRECTED ON THIS DRAWING AS THIS DRAWING WILL BE CONSIDERED ALL INCLUSIVE \*\*\*

ALL GRAPHICS PROVIDED ARE FOR REFERENCE ONLY. IF CERTAIN DIMENSIONS ARE CRITICAL PLEASE VERIFY THOSE DIMENSIONS WITH YOUR SALESPERSON

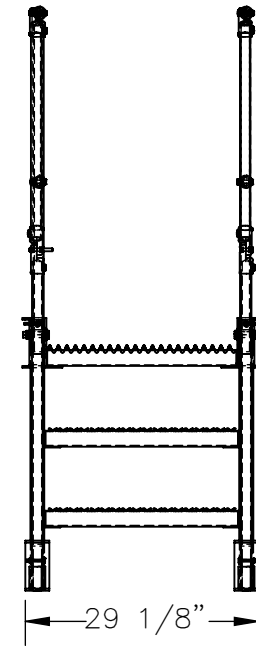
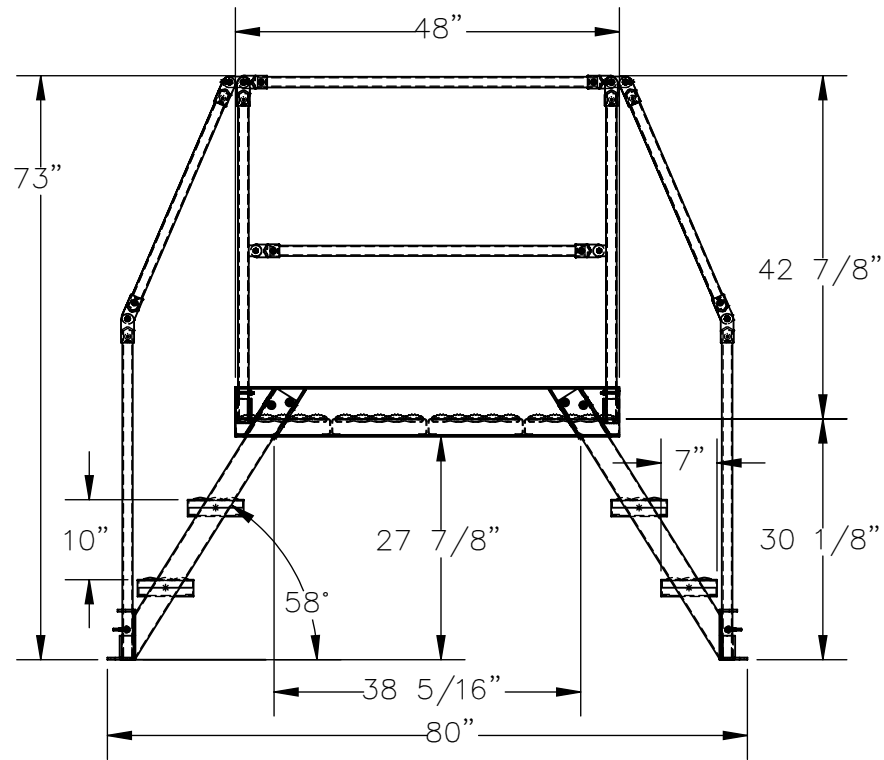
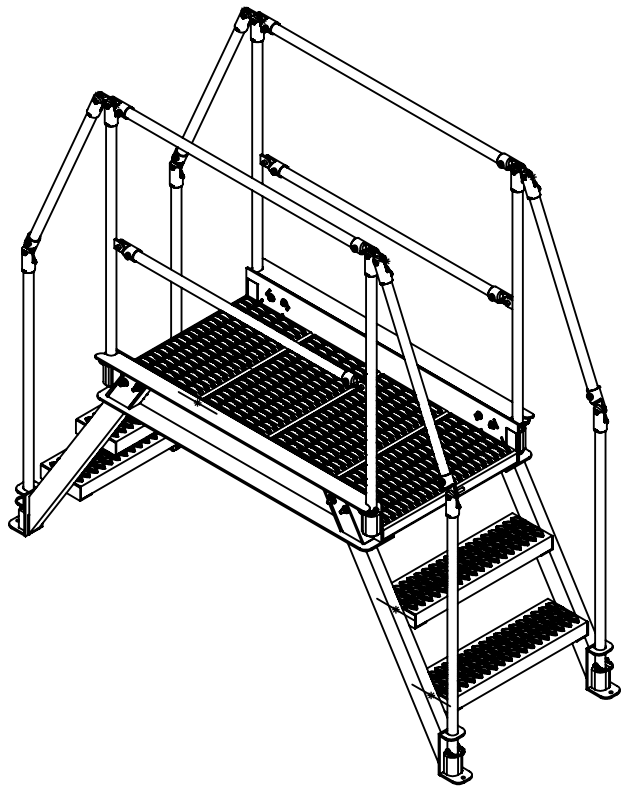

DIMENSION TOLERANCE ± 1/4"

## STANDARD FEATURES:

MODEL NUMBER: COL-AL-3-26-33

OVERALL SIZE

29 1/8" W x 80" L x 72 15/16" H

CLEARANCE SPAN:

38 5/16" W x 27 7/8" H

TOP PLATFORM HEIGHT: 30 1/8"

STEP HEIGHT SPACING: 10"

STEP DEPTH: 7"

STEP & PLATFORM WIDTH: 29 1/8"

CLIMB ANGLE: 58°

OVERALL CAPACITY: 500 LBS.

ALUMINUM CONSTRUCTION

HANDRAILS TOUGH BAKED IN

POWDER COATED YELLOW FINISH

## SPECIAL FEATURES

NONE

APPROVAL

I, THE UNDERSIGNED, AGREE THAT THE PRODUCT AS REPRESENTED SATISFIES DESIGN AND DIMENSION REQUIREMENTS. I ALSO ACKNOWLEDGE MY DUTY TO CONFIRM PRODUCT AND INSTALLATION COMPLIANCE WITH ALL APPLICABLE FEDERAL, STATE AND LOCAL REGULATIONS AND STANDARDS.  
**UNITS REQUIRING APPROVAL DRAWINGS OR MODIFIED ARE NON-RETURNABLE**

As drawn       As marked

Signed: \_\_\_\_\_ Date: \_\_\_\_\_

Printed Name: \_\_\_\_\_

LEAD TIME WILL START UPON RECEIPT OF SIGNED APPROVAL DRAWING

DISTRIBUTOR'S NAME:		P.O.#
VESTIL MANUFACTURING		X
DRAWN BY: T. HARKRADER		W.O.#
DATE: 8/25/21		X
REFERENCE: X	SCALE: 1:24	SALES: X
QUOTED LEAD TIME: X	QUOTE #	FILE NAME:
	X	44-007-771