

SIX STEP, ALUMINUM, CROSS OVER - COL-AL-6-56-33

APPROX WEIGHT: 202.31 lbs.
DOES NOT INCLUDE WEIGHT OF POWER OR PACKAGING!!!

*** ANY ADDITIONS, DELETIONS, OR OMISSIONS MUST BE CORRECTED ON THIS DRAWING AS THIS DRAWING WILL BE CONSIDERED ALL INCLUSIVE ***
ALL GRAPHICS PROVIDED ARE FOR REFERENCE ONLY. IF CERTAIN DIMENSIONS ARE CRITICAL PLEASE VERIFY THOSE DIMENSIONS WITH YOUR SALESPERSON

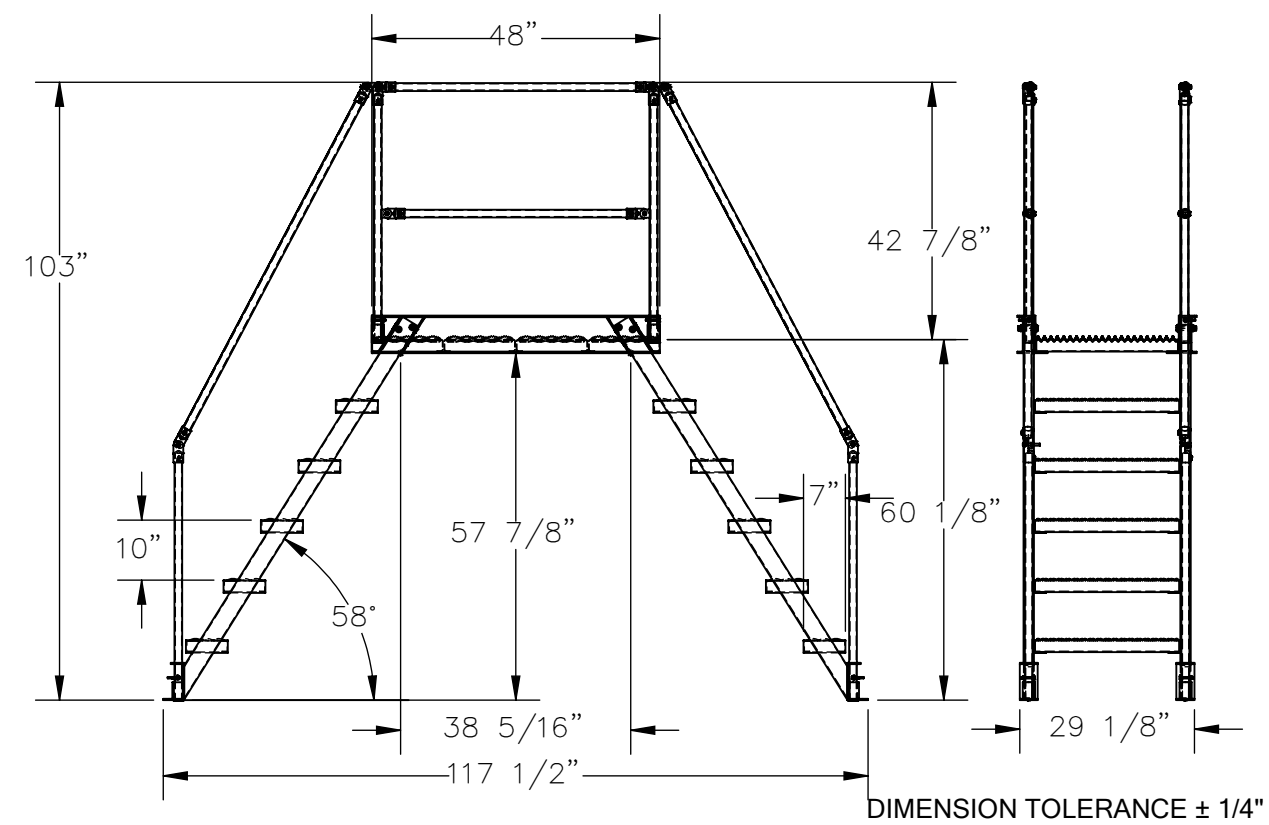
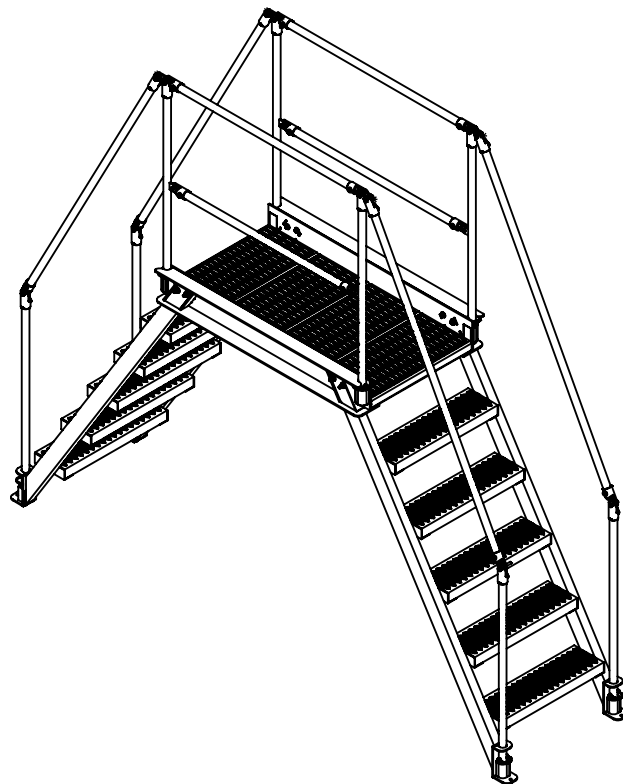

STANDARD FEATURES:
MODEL NUMBER: COL-AL-6-56-33
OVERALL SIZE
 29 1/8" W x 117 1/2" L x 102 15/16" H
CLEARANCE SPAN:
 38 5/16" W x 57 7/8" H
TOP PLATFORM HEIGHT: 60 1/8"
STEP HEIGHT SPACING: 10"
STEP DEPTH: 7"
STEP & PLATFORM WIDTH: 29 1/8"
CLIMB ANGLE: 58°
OVERALL CAPACITY: 500 LBS.
ALUMINUM CONSTRUCTION
HANDRAILS TOUGH BAKED IN
POWDER COATED YELLOW FINISH

SPECIAL FEATURES:
 NONE

A P P R O V A L

I, THE UNDERSIGNED, AGREE THAT THE PRODUCT AS REPRESENTED SATISFIES DESIGN AND DIMENSION REQUIREMENTS. I ALSO ACKNOWLEDGE MY DUTY TO CONFIRM PRODUCT AND INSTALLATION COMPLIANCE WITH ALL APPLICABLE FEDERAL, STATE AND LOCAL REGULATIONS AND STANDARDS.

UNITS REQUIRING APPROVAL DRAWINGS OR MODIFIED ARE NON-RETURNABLE

[] As drawn [] As marked

Signed: _____ Date: _____

Printed Name: _____

LEAD TIME WILL START UPON RECEIPT OF SIGNED APPROVAL DRAWING

DISTRIBUTOR'S NAME:		P.O.#
VESTIL MANUFACTURING		X
DRAWN BY: T. HARKRADER		W.O.#
DATE: 8/25/21		X
REFERENCE: X	SCALE: 1:32	SALES: X
QUOTED LEAD TIME: X	QUOTE #	FILE NAME:
	X	44-007-783