



**VESTIL MANUFACTURING COMPANY**  
 2999 North Wayne Street, P.O. Box 507, Angola, IN 46703  
 Telephone: (260) 665-7586 -or- Toll Free (800) 348-0868  
 Fax: (260) 665-1339  
[www.vestil.com](http://www.vestil.com) e-mail: [info@vestil.com](mailto:info@vestil.com)

## COL & COL-HDG (HOT DIP GALVANIZED) CROSS OVER LADDERS



\*Model COL-3-26-44-HDG shown

**Receiving Instructions**

After delivery, remove the packaging from the product. Inspect the product closely to determine whether it sustained damage during transport. If damage is discovered, record a complete description of it on the bill of lading. If the product is undamaged, discard the packaging.

**NOTE:** The end-user is solely responsible for confirming that product design, use, and maintenance comply with laws, regulations, codes, and mandatory standards applied where the product is used.

**Technical Service & Replacement Parts**

For answers to questions not addressed in these instructions and to order replacement parts, labels, and accessories, call our Technical Service and Parts Department at (260) 665-7586. The department can also be contacted online at <https://www.vestil.com/page-parts-request.php>.

**Electronic copies of Instruction Manuals**

Additional copies of this instruction manual may be downloaded from <https://www.vestil.com/page-manuals.php>

<b>Table of Contents</b>		<b>Page</b>
Signal Words.....		2
Safety Instructions.....		2
Exploded Parts Diagrams and Bills of Materials.....		3 - 18
Assembling the Crossover Ladder.....		19 - 22
Record of Satisfactory Condition.....		22
Inspections and Maintenance.....		22
Labeling Diagram.....		23
Limited Warranty.....		24

## SIGNAL WORDS

This manual uses SIGNAL WORDS to indicate the likelihood of personal injuries, as well as the probable seriousness of those injuries, if the product is misused in the ways described. Other signal words call attention to uses of the product likely cause property damage. The following are signal words used in this manual and their definitions.

### DANGER

Identifies a hazardous situation which, if not avoided, **WILL** result in **DEATH** or **SERIOUS INJURY**. Use of this signal word is limited to the **most extreme situations**.

### WARNING

Identifies a hazardous situation which, if not avoided, **COULD** result in **DEATH** or **SERIOUS INJURY**.

### CAUTION

Indicates a hazardous situation which, if not avoided, **COULD** result in **MINOR** or **MODERATE** injury.

### NOTICE

Identifies practices likely to result in product/property damage, such as operation that might damage the product.

## SAFETY INSTRUCTIONS

Vestil strives to identify foreseeable hazards associated with the use of its products. However, no manual can address every conceivable risk. Minimize the likelihood of injury by observing the hazards identified below and by inspecting and maintaining the product as instructed in [INSPECTIONS AND MAINTENANCE](#) on p. 22.

### WARNING

Risks of serious personal injuries.

- **Read and understand this entire manual before installing, assembling, using or servicing this crossover.** Keep this manual in a location known to persons who use the crossover. Read the manual whenever necessary to refresh your understanding of proper use, inspection, and maintenance procedures.
- DO NOT exceed the 500 pound (227kg) capacity. The total weight applied to the crossover (weight of the user plus tools, etc.) must not be greater than 500 pounds.
- DO NOT install the crossover on uneven or unstable surfaces. ONLY install the crossover on level, even surfaces. Install the crossover in a location where users cannot contact overhead objects. In particular, there must be no possibility of users contacting electrical wiring.
- DO NOT use the crossover if you tire quickly or easily, or if you have experienced fainting spells. DO NOT use the crossover if you are under the influence of alcohol, medication, or other substances that affect your balance or coordination. Only use the crossover if you are in good health.
- Make sure that you will not contact overhead objects with your body during use.
- Inspect the truck as directed in [INSPECTIONS AND MAINTENANCE](#) on page 22. DO NOT use the device unless it is in *satisfactory condition*. See [RECORD OF SATISFACTORY CONDITION](#) on p. 22.
- Always unload the crossover before leaving it unattended.
- Remove foreign matter, like mud, oil, and grease, from your shoes before walking on the crossover.
- ALWAYS face the stairs and use the handrails while ascending and descending the steps.
- DO NOT increase the height of the platform, or a step, by standing on other objects placed on the crossover. For instance, do not use a step stool on the crossover platform.
- Children must not play on the crossover. Apply measures to prevent access to the crossover by children.
- Inspect the crossover as described in [INSPECTIONS AND MAINTENANCE](#). DO NOT use the crossover unless it is in normal condition. ONLY use manufacturer-approved replacement parts if repairs are necessary.
- DO NOT use the crossover if any of the feet (at the base of each stairway) are damaged, unstable, corroded, etc. The crossover should be rigidly fastened to the floor. It should not wobble to any degree.
- DO NOT store items on the crossover. Only use this product as it is intended, i.e. as a pedestrian walkway.
- DO NOT lean or reach over the sides of the crossover. Keep your center of gravity (belly button) between the handrails.
- DO NOT use this product UNLESS every label shown in the [LABELING DIAGRAM](#) on p. 23 is in place, undamaged, and easily readable.
- DO NOT modify the crossover in any way without express, written approval from Vestil. Unapproved modifications automatically void the [LIMITED WARRANTY](#) on p. 24 and might make the product unsafe to use.

# Exploded View & Bill of Materials: COL-3-26-14(-HDG)

44-006-728

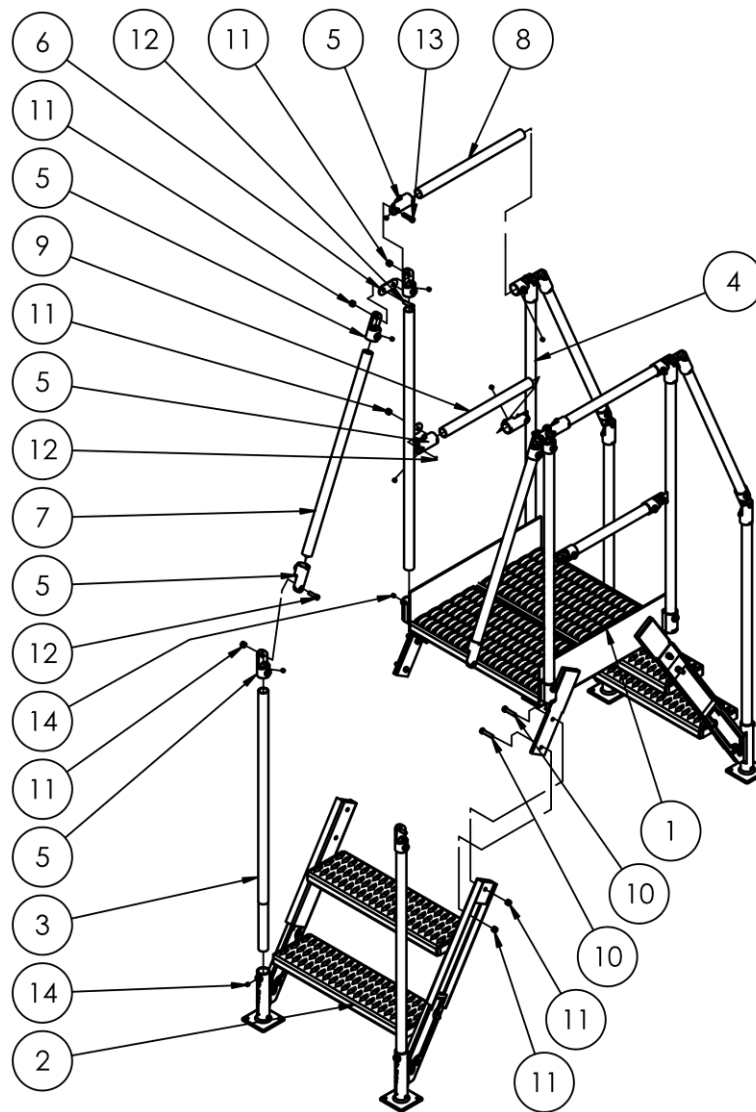

ITEM	PART NUMBER	DESCRIPTION	QTY.
1	44-513-010	WELDMENT, FRAME, PLATFORM	1
2	44-514-051	WELDMENT, FRAME, STEPS	2
3	44-024-066	GUARD, HANDRAIL, UPRIGHTS, 40 7/8" LG. COL-3-26-14	4
	44-024-361	COL-3-26-14-HDG	4
4	44-524-031	GUARD, WELDMENT, UPRIGHT, COL	4
5	44-516-016	ASSEMBLY, HANDRAIL, PIPE END	24
6	44-016-012	BRACKET, UPPER HANDRAIL	4
7	44-024-057	GUARD, HANDRAIL, STEPS, 28 3/4" LG.	4
8	44-024-061	GUARD, HANDRAIL, UPPER, 18 7/8" LG.	2
9	44-024-065	GUARD, HANDRAIL, MIDRAIL, 15 7/8" LG.	2
10	11110	HEX BOLT, GRADE A, ZINC FINISH, 3/8"-16 X 1 3/4"	8
11	37024	NYLON INSERT LOCK NUT, GRADE 2, ZINC FINISH, 3/8"-16	24
12	23307	SOCKET HEAD CAP SCREW, 3/8 - 16 x 1 1/4 LG.	12
13	23309	SOCKET HEAD BOLT, 3/8 - 16 UNC x 1 1/2" LG.	4
14	25537	3/8 - 16 x 3/8 CUP-POINT SET SCREW	8

# Exploded View & Bill of Materials: COL-3-26-23-HDG

44-006-729

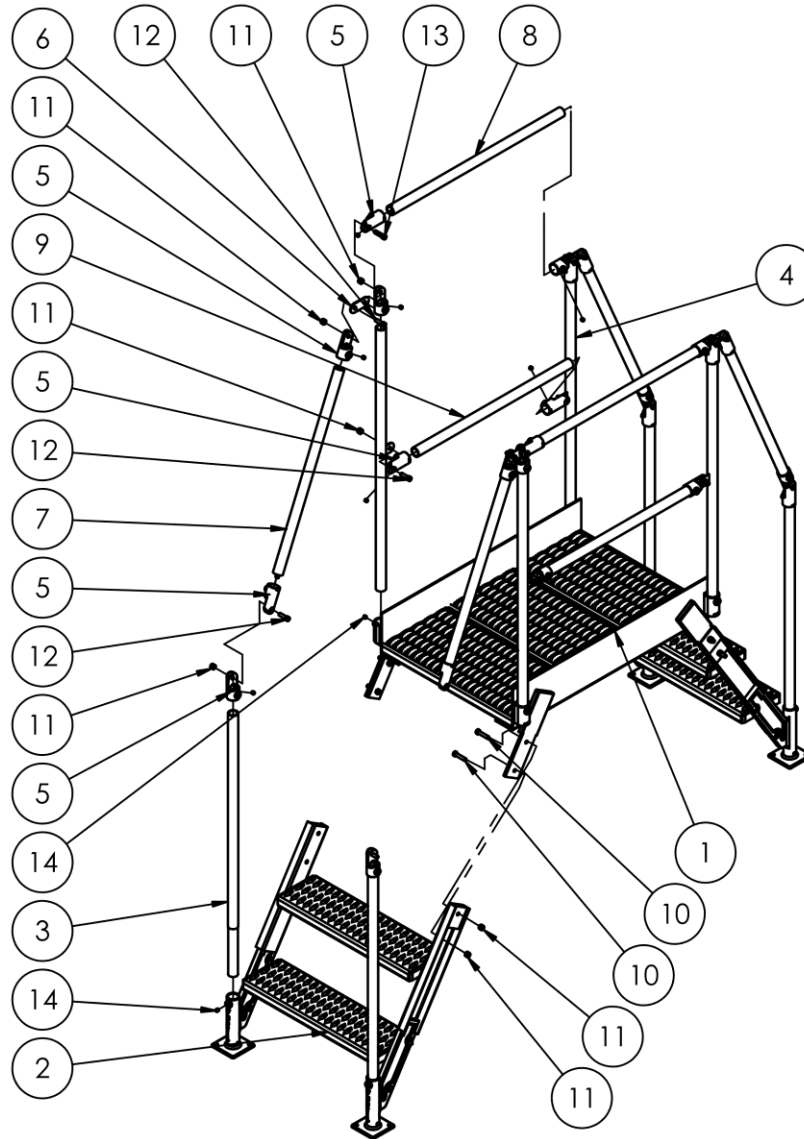

ITEM	PART NUMBER	DESCRIPTION	QTY.
1	44-513-011	WELDMENT, FRAME, PLATFORM	1
2	44-514-051	WELDMENT, FRAME, STEPS	2
3	44-024-066	GUARD, HANDRAIL, UPRIGHTS, 40 7/8" LG.	4
	44-024-361	COL-3-26-23-HDG	4
4	44-524-031	GUARD, WELDMENT, UPRIGHT, COL	4
5	44-516-016	ASSEMBLY, HANDRAIL, PIPE END	24
6	44-016-012	BRACKET, UPPER HANDRAIL	4
7	44-024-057	GUARD, HANDRAIL, STEPS, 28 3/4" LG.	4
8	44-024-060	GUARD, HANDRAIL, UPPER, 30 7/8" LG.	2
9	44-024-064	GUARD, HANDRAIL, MIDRAIL, 27 7/8" LG.	2
10	11110	HEX BOLT, GRADE A, ZINC FINISH, 3/8"-16 X 1 3/4"	8
11	37024	NYLON INSERT LOCK NUT, GRADE 2, ZINC FINISH, 3/8"-16	24
12	23307	SOCKET HEAD CAP SCREW, 3/8 - 16 x 1 1/4 LG.	12
13	23309	SOCKET HEAD BOLT, 3/8 - 16 UNC x 1 1/2" LG.	4
14	25537	3/8 - 16 x 3/8 CUP-POINT SET SCREW	8

# Exploded View & Bill of Materials: COL-3-26-33-HDG

44-006-730

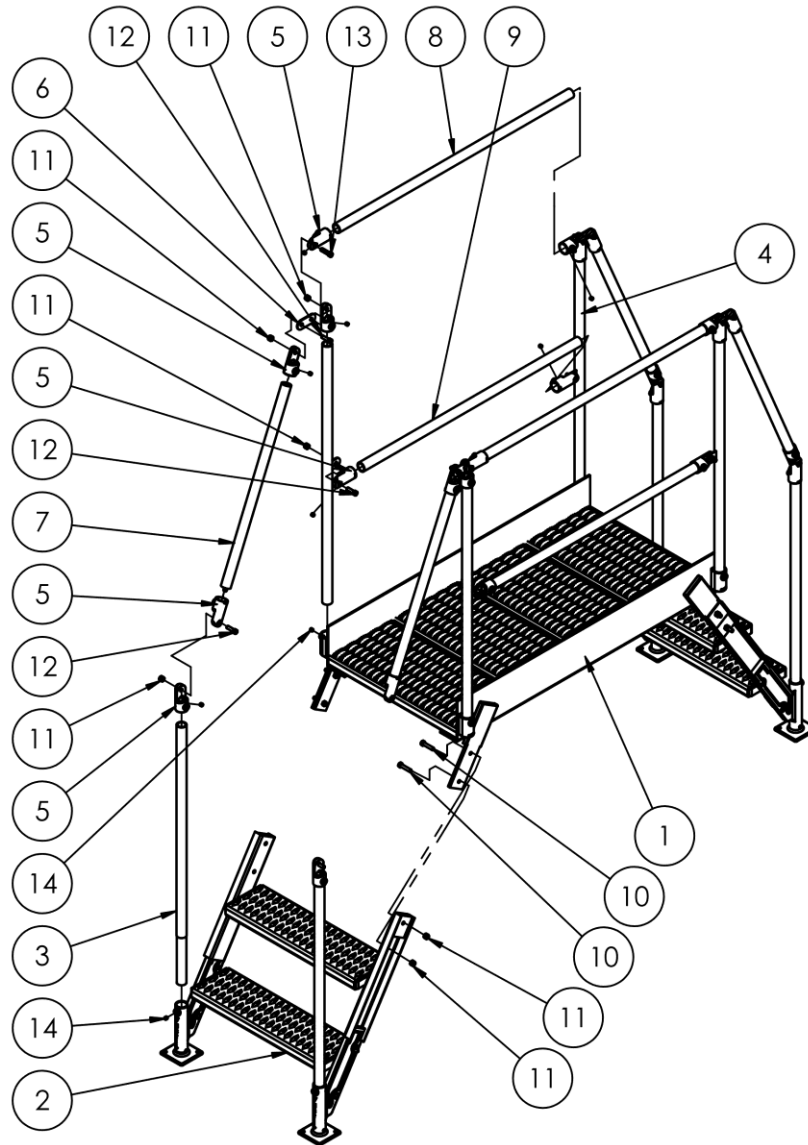

ITEM	PART NUMBER	DESCRIPTION	QTY.
1	44-513-012	WELDMENT, FRAME, PLATFORM	1
2	44-514-051	WELDMENT, FRAME, STEPS	2
3	44-024-066	GUARD, HANDRAIL, UPRIGHTS, 40 7/8" LG. COL-3-26-33	4
	44-024-361	COL-3-26-33-HDG	4
4	44-524-031	GUARD, WELDMENT, UPRIGHT, COL	4
5	44-516-016	ASSEMBLY, HANDRAIL, PIPE END	24
6	44-016-012	BRACKET, UPPER HANDRAIL	4
7	44-024-057	GUARD, HANDRAIL, STEPS, 28 3/4" LG.	4
8	44-024-059	GUARD, HANDRAIL, UPPER, 42 7/8" LG.	2
9	44-024-063	GUARD, HANDRAIL, MIDRAIL, 39 7/8" LG.	2
10	11110	HEX BOLT, GRADE A, ZINC FINISH, 3/8"-16 X 1 3/4"	8
11	37024	NYLON INSERT LOCK NUT, GRADE 2, ZINC FINISH, 3/8"-16	24
12	23307	SOCKET HEAD CAP SCREW, 3/8 - 16 x 1 1/4 LG.	12
13	23309	SOCKET HEAD BOLT, 3/8 - 16 UNC x 1 1/2" LG.	4
14	25537	3/8 - 16 x 3/8 CUP-POINT SET SCREW	8



# Exploded View & Bill of Materials: COL-3-26-44-HDG

44-006-731

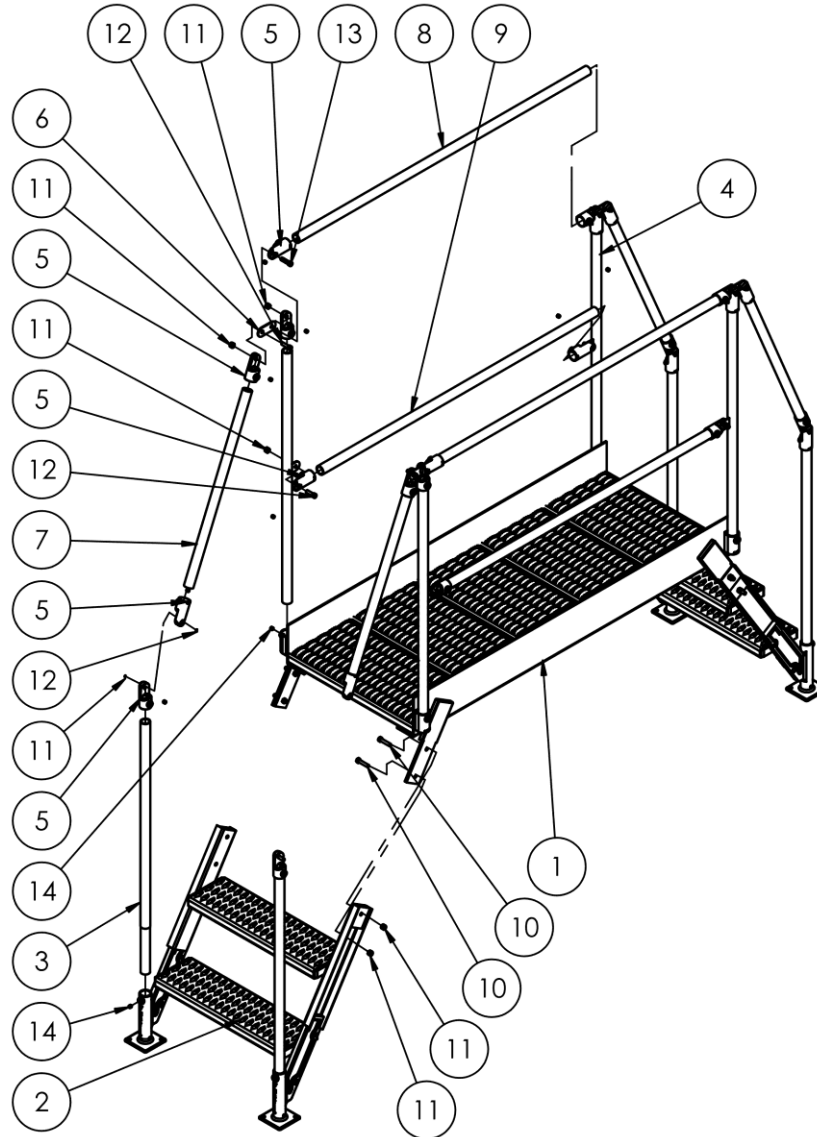

ITEM	PART NUMBER	DESCRIPTION	QTY.
1	44-513-012	WELDMENT, FRAME, PLATFORM	1
2	44-514-051	WELDMENT, FRAME, STEPS	2
3	44-024-066	GUARD, HANDRAIL, UPRIGHTS, 40 7/8" LG.	4
	44-024-361	COL-3-26-44-HDG	4
4	44-524-031	GUARD, WELDMENT, UPRIGHT, COL	4
5	44-516-016	ASSEMBLY, HANDRAIL, PIPE END	24
6	44-016-012	BRACKET, UPPER HANDRAIL	4
7	44-024-057	GUARD, HANDRAIL, STEPS, 28 3/4" LG.	4
8	44-024-059	GUARD, HANDRAIL, UPPER, 42 7/8" LG.	2
9	44-024-063	GUARD, HANDRAIL, MIDRAIL, 39 7/8" LG.	2
10	11110	HEX BOLT, GRADE A, ZINC FINISH, 3/8"-16 X 1 3/4"	8
11	37024	NYLON INSERT LOCK NUT, GRADE 2, ZINC FINISH, 3/8"-16	24
12	23307	SOCKET HEAD CAP SCREW, 3/8 - 16 x 1 1/4 LG.	12
13	23309	SOCKET HEAD BOLT, 3/8 - 16 UNC x 1 1/2" LG.	4
14	25537	3/8 - 16 x 3/8 CUP-POINT SET SCREW	8

# Exploded View & Bill of Materials: COL-4-36-14-HDG

44-006-732

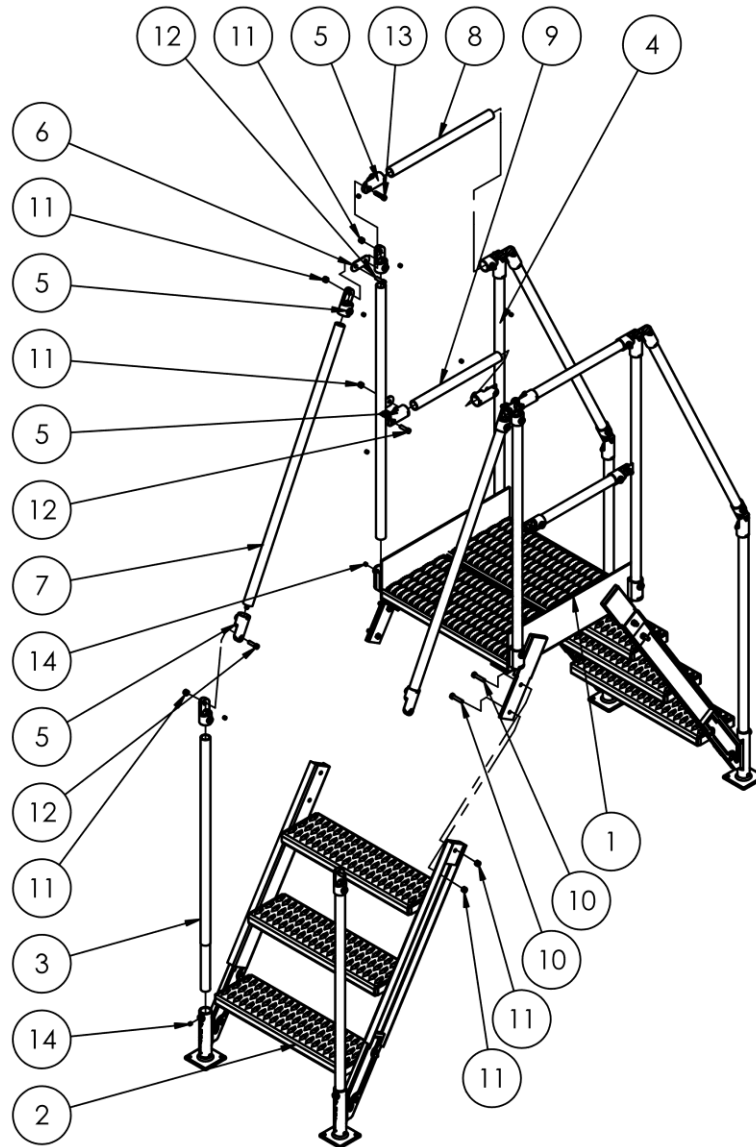

ITEM	PART NUMBER	DESCRIPTION	QTY.
1	44-513-010	WELDMENT, FRAME, PLATFORM	1
2	44-514-050	WELDMENT, FRAME, STEPS	2
3	44-024-066	GUARD, HANDRAIL, UPRIGHTS, 40 7/8" LG. COL-4-36-14	4
	44-024-361	COL-4-36-14-HDG	4
4	44-524-031	GUARD, WELDMENT, UPRIGHT, COL	4
5	44-516-016	ASSEMBLY, HANDRAIL, PIPE END	24
6	44-016-012	BRACKET, UPPER HANDRAIL	4
7	44-024-056	GUARD, HANDRAIL, STEPS, 40 5/8" LG.	4
8	44-024-061	GUARD, HANDRAIL, UPPER, 18 7/8" LG.	2
9	44-024-065	GUARD, HANDRAIL, MIDRAIL, 15 7/8" LG.	2
10	11110	HEX BOLT, GRADE A, ZINC FINISH, 3/8"-16 X 1 3/4"	8
11	37024	NYLON INSERT LOCK NUT, GRADE 2, ZINC FINISH, 3/8"-16	24
12	23307	SOCKET HEAD CAP SCREW, 3/8 - 16 x 1 1/4 LG.	12
13	23309	SOCKET HEAD BOLT, 3/8 - 16 UNC x 1 1/2" LG.	4
14	25537	3/8 - 16 x 3/8 CUP-POINT SET SCREW	8

# Exploded View & Bill of Materials: COL-4-36-23-HDG

44-006-733

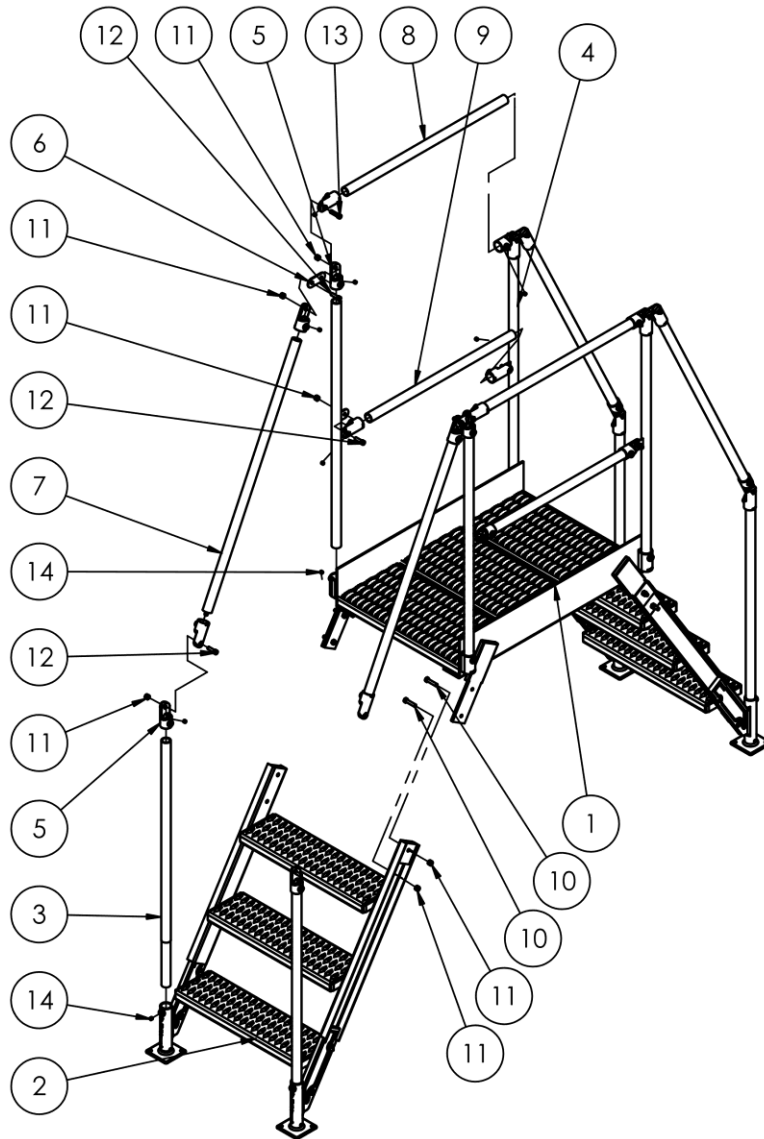

ITEM	PART NUMBER	DESCRIPTION	QTY.
1	44-513-011	WELDMENT, FRAME, PLATFORM	1
2	44-514-050	WELDMENT, FRAME, STEPS	2
3	44-024-066	GUARD, HANDRAIL, UPRIGHTS, 40 7/8" LG.	4
	44-024-361	COL-4-36-23 COL-4-36-23-HDG	4
4	44-524-031	GUARD, WELDMENT, UPRIGHT, COL	4
5	44-516-016	ASSEMBLY, HANDRAIL, PIPE END	24
6	44-016-012	BRACKET, UPPER HANDRAIL	4
7	44-024-056	GUARD, HANDRAIL, STEPS, 40 5/8" LG.	4
8	44-024-060	GUARD, HANDRAIL, UPPER, 30 7/8" LG.	2
9	44-024-064	GUARD, HANDRAIL, MIDRAIL, 27 7/8" LG.	2
10	11110	HEX BOLT, GRADE A, ZINC FINISH, 3/8"-16 X 1 3/4"	8
11	37024	NYLON INSERT LOCK NUT, GRADE 2, ZINC FINISH, 3/8"-16	24
12	23307	SOCKET HEAD CAP SCREW, 3/8 - 16 x 1 1/4 LG.	12
13	23309	SOCKET HEAD BOLT, 3/8 - 16 UNC x 1 1/2" LG.	4
14	25537	3/8 - 16 x 3/8 CUP-POINT SET SCREW	8



# Exploded View & Bill of Materials: COL-4-36-33-HDG

44-006-734

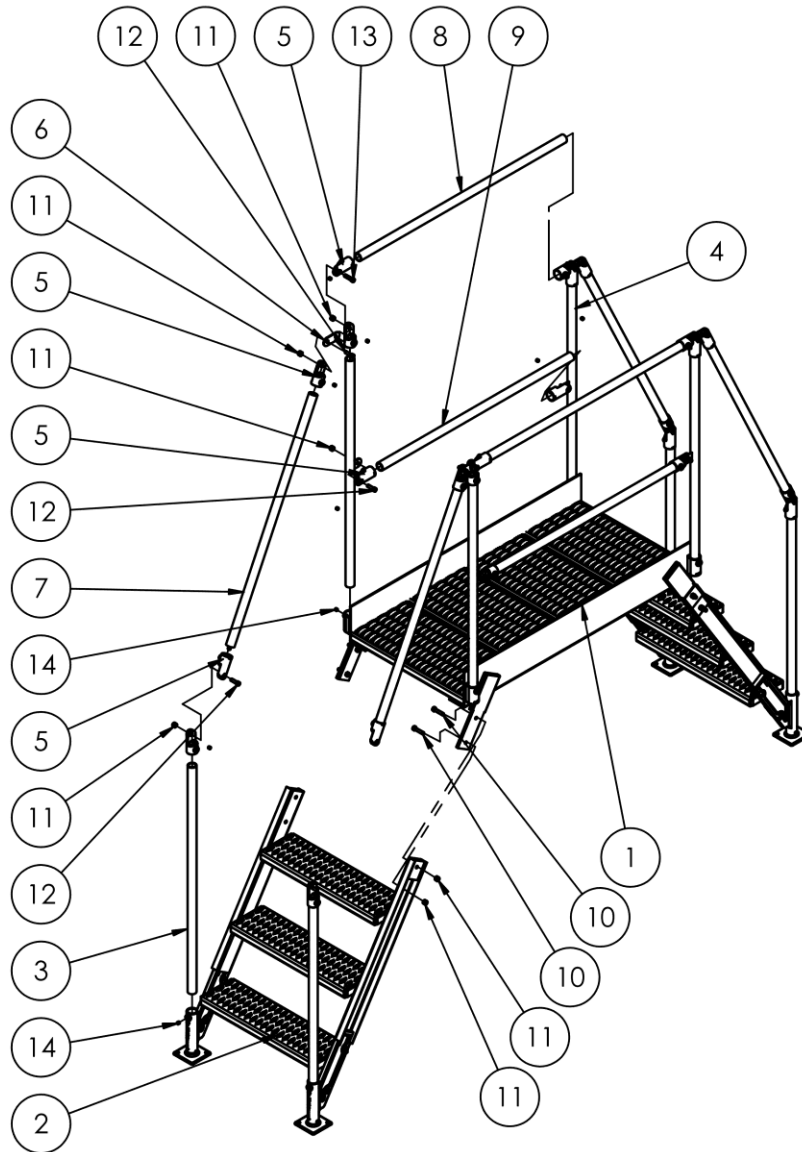

ITEM	PART NUMBER	DESCRIPTION	QTY.
1	44-513-012	WELDMENT, FRAME, PLATFORM	1
2	44-514-050	WELDMENT, FRAME, STEPS	2
3	44-024-066	GUARD, HANDRAIL, UPRIGHTS, 40 7/8" LG.	4
	44-024-361	COL-4-36-33 COL-4-36-33-HDG	4
4	44-524-031	GUARD, WELDMENT, UPRIGHT, COL	4
5	44-516-016	ASSEMBLY, HANDRAIL, PIPE END	24
6	44-016-012	BRACKET, UPPER HANDRAIL	4
7	44-024-056	GUARD, HANDRAIL, STEPS, 40 5/8" LG.	4
8	44-024-059	GUARD, HANDRAIL, UPPER, 42 7/8" LG.	2
9	44-024-063	GUARD, HANDRAIL, MIDRAIL, 39 7/8" LG.	2
10	11110	HEX BOLT, GRADE A, ZINC FINISH, 3/8"-16 X 1 3/4"	8
11	37024	NYLON INSERT LOCK NUT, GRADE 2, ZINC FINISH, 3/8"-16	24
12	23307	SOCKET HEAD CAP SCREW, 3/8 - 16 x 1 1/4 LG.	12
13	23309	SOCKET HEAD BOLT, 3/8 - 16 UNC x 1 1/2" LG.	4
14	25537	3/8 - 16 x 3/8 CUP-POINT SET SCREW	8

# Exploded View & Bill of Materials: COL-4-36-44-HDG

44-006-735

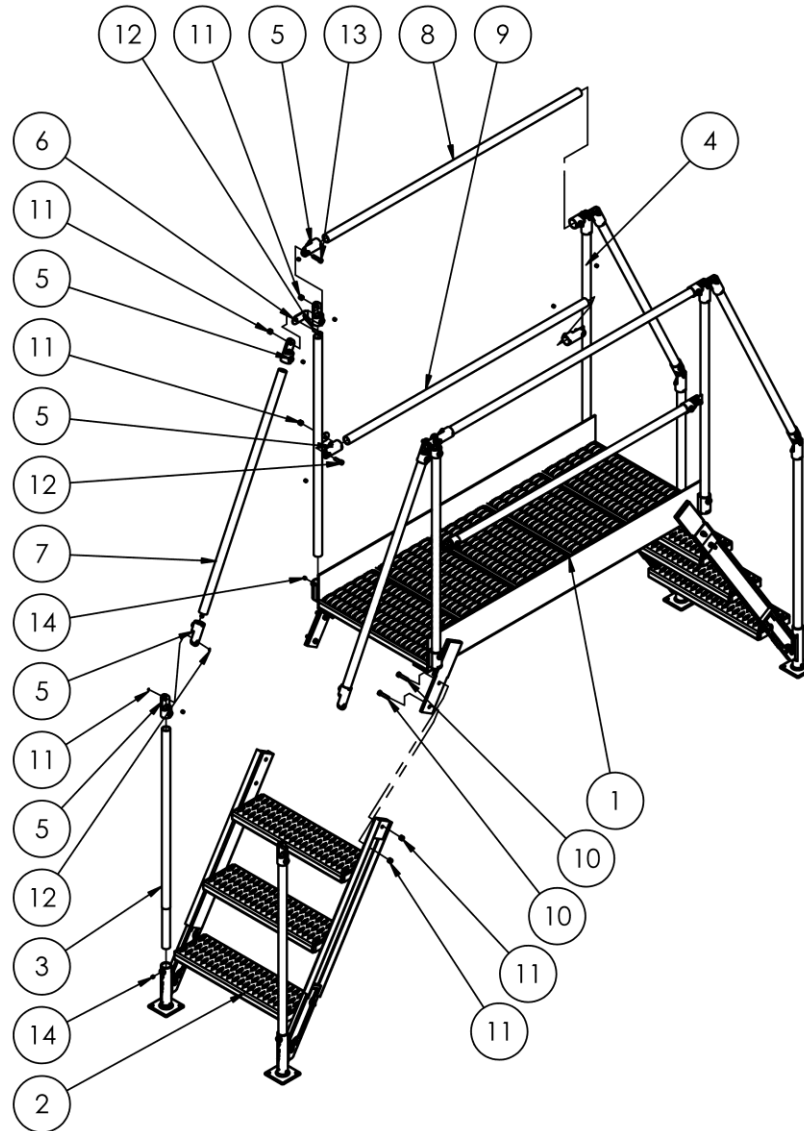

ITEM	PART NUMBER	DESCRIPTION	QTY.
1	44-513-013	WELDMENT, FRAME, PLATFORM	1
2	44-514-050	WELDMENT, FRAME, STEPS	2
3	44-024-066	GUARD, HANDRAIL, UPRIGHTS, 40 7/8" LG. COL-4-36-44	4
	44-024-361	COL-4-36-44-HDG	4
4	44-524-031	GUARD, WELDMENT, UPRIGHT, COL	4
5	44-516-016	ASSEMBLY, HANDRAIL, PIPE END	24
6	44-016-012	BRACKET, UPPER HANDRAIL	4
7	44-024-056	GUARD, HANDRAIL, STEPS, 40 5/8" LG.	4
8	44-024-058	GUARD, HANDRAIL, UPPER, 54 7/8" LG.	2
9	44-024-170	GUARD, HANDRAIL, MIDRAIL, 51 7/8" LG.	2
10	11110	HEX BOLT, GRADE A, ZINC FINISH, 3/8"-16 X 1 3/4"	8
11	37024	NYLON INSERT LOCK NUT, GRADE 2, ZINC FINISH, 3/8"-16	24
12	23307	SOCKET HEAD CAP SCREW, 3/8 - 16 x 1 1/4 LG.	12
13	23309	SOCKET HEAD BOLT, 3/8 - 16 UNC x 1 1/2" LG.	4
14	25537	3/8 - 16 x 3/8 CUP-POINT SET SCREW	8

# Exploded View & Bill of Materials: COL-5-46-14-HDG

44-006-736

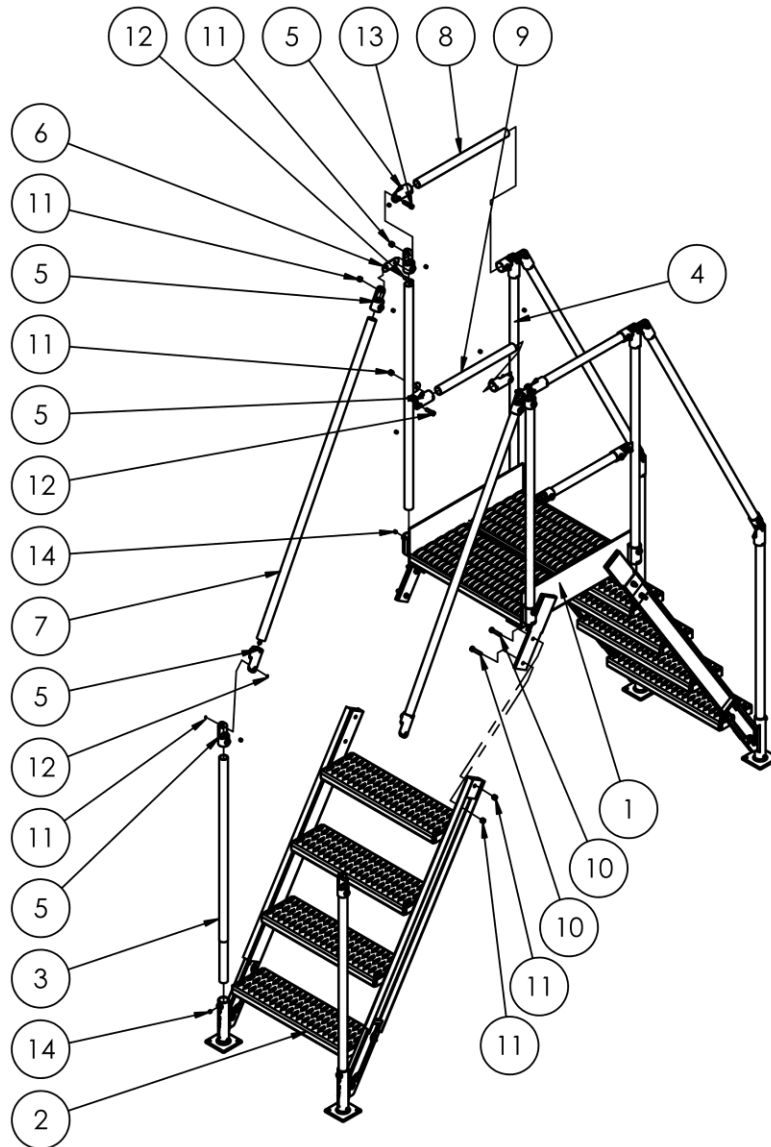

ITEM	PART NUMBER	DESCRIPTION	QTY.
1	44-513-010	WELDMENT, FRAME, PLATFORM	1
2	44-514-049	WELDMENT, FRAME, STEPS	2
3	44-024-066	GUARD, HANDRAIL, UPRIGHTS, 40 7/8" LG. COL-5-46-14	4
	44-024-361	COL-5-46-14-HDG	4
4	44-524-031	GUARD, WELDMENT, UPRIGHT, COL	4
5	44-516-016	ASSEMBLY, HANDRAIL, PIPE END	24
6	44-016-012	BRACKET, UPPER HANDRAIL	4
7	44-024-055	GUARD, HANDRAIL, STEPS, 52 3/8" LG.	4
8	44-024-061	GUARD, HANDRAIL, UPPER, 18 7/8" LG.	2
9	44-024-065	GUARD, HANDRAIL, MIDRAIL, 15 7/8" LG.	2
10	11110	HEX BOLT, GRADE A, ZINC FINISH, 3/8"-16 X 1 3/4"	8
11	37024	NYLON INSERT LOCK NUT, GRADE 2, ZINC FINISH, 3/8"-16	24
12	23307	SOCKET HEAD CAP SCREW, 3/8 - 16 x 1 1/4 LG.	12
13	23309	SOCKET HEAD BOLT, 3/8 - 16 UNC x 1 1/2" LG.	4
14	25537	3/8 - 16 x 3/8 CUP-POINT SET SCREW	8

# Exploded View & Bill of Materials: COL-5-46-23-HDG

44-006-737

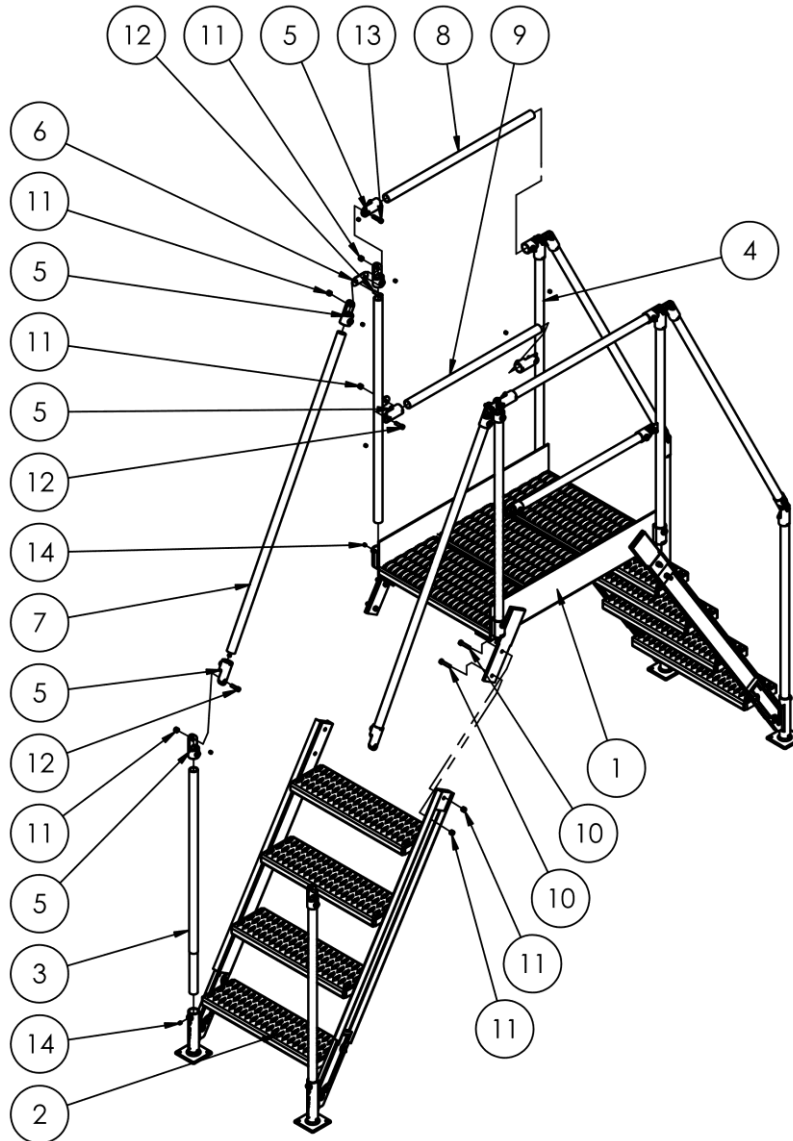

ITEM	PART NUMBER	DESCRIPTION	QTY.
1	44-513-011	WELDMENT, FRAME, PLATFORM	1
2	44-514-049	WELDMENT, FRAME, STEPS	2
3	44-024-066	GUARD, HANDRAIL, UPRIGHTS, 40 7/8" LG.	4
	44-024-361	COL-5-46-23 COL-5-46-23-HDG	4
4	44-524-031	GUARD, WELDMENT, UPRIGHT, COL	4
5	44-516-016	ASSEMBLY, HANDRAIL, PIPE END	24
6	44-016-012	BRACKET, UPPER HANDRAIL	4
7	44-024-055	GUARD, HANDRAIL, STEPS, 52 3/8" LG.	4
8	44-024-060	GUARD, HANDRAIL, UPPER, 30 7/8" LG.	2
9	44-024-064	GUARD, HANDRAIL, MIDRAIL, 27 7/8" LG.	2
10	11110	HEX BOLT, GRADE A, ZINC FINISH, 3/8"-16 X 1 3/4"	8
11	37024	NYLON INSERT LOCK NUT, GRADE 2, ZINC FINISH, 3/8"-16	24
12	23307	SOCKET HEAD CAP SCREW, 3/8 - 16 x 1 1/4 LG.	12
13	23309	SOCKET HEAD BOLT, 3/8 - 16 UNC x 1 1/2" LG.	4
14	25537	3/8 - 16 x 3/8 CUP-POINT SET SCREW	8

# Exploded View & Bill of Materials: COL-5-46-33-HDG

44-006-738

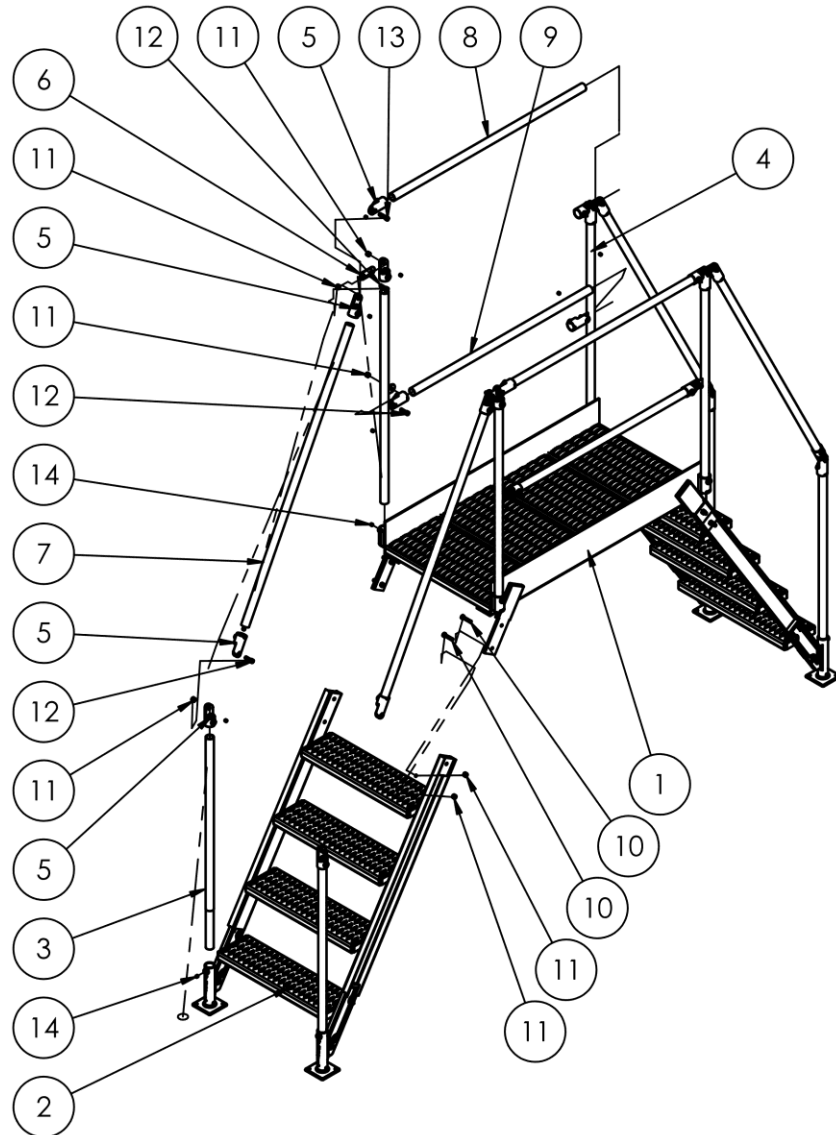

ITEM	PART NUMBER	DESCRIPTION	QTY.
1	44-513-012	WELDMENT, FRAME, PLATFORM	1
2	44-514-049	WELDMENT, FRAME, STEPS	2
3	44-024-066	GUARD, HANDRAIL, UPRIGHTS, 40 7/8" LG.	4
	44-024-361	COL-5-46-33 COL-5-46-33-HDG	4
4	44-524-031	GUARD, WELDMENT, UPRIGHT, COL	4
5	44-516-016	ASSEMBLY, HANDRAIL, PIPE END	24
6	44-016-012	BRACKET, UPPER HANDRAIL	4
7	44-024-055	GUARD, HANDRAIL, STEPS, 52 3/8" LG.	4
8	44-024-059	GUARD, HANDRAIL, UPPER, 42 7/8" LG.	2
9	44-024-063	GUARD, HANDRAIL, MIDRAIL, 39 7/8" LG.	2
10	11110	HEX BOLT, GRADE A, ZINC FINISH, 3/8"-16 X 1 3/4"	8
11	37024	NYLON INSERT LOCK NUT, GRADE 2, ZINC FINISH, 3/8"-16	24
12	23307	SOCKET HEAD CAP SCREW, 3/8 - 16 x 1 1/4 LG.	12
13	23309	SOCKET HEAD BOLT, 3/8 - 16 UNC x 1 1/2" LG.	4
14	25537	3/8 - 16 x 3/8 CUP-POINT SET SCREW	8



# Exploded View & Bill of Materials: COL-5-46-44-HDG

44-006-739

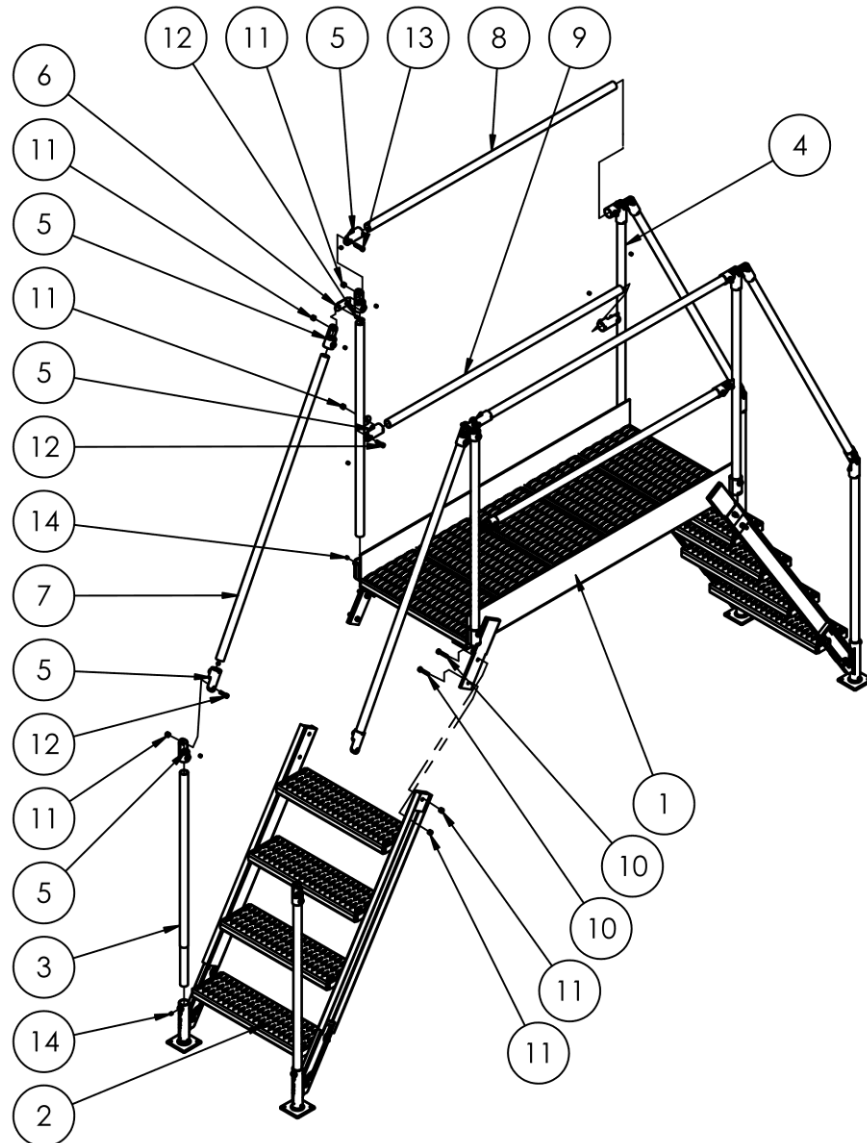

ITEM	PART NUMBER	DESCRIPTION	QTY.
1	44-513-013	WELDMENT, FRAME, PLATFORM	1
2	44-514-049	WELDMENT, FRAME, STEPS	2
3	44-024-066	GUARD, HANDRAIL, UPRIGHTS, 40 7/8" LG.	4
	44-024-361	COL-5-46-44-HDG	4
4	44-524-031	GUARD, WELDMENT, UPRIGHT, COL	4
5	44-516-016	ASSEMBLY, HANDRAIL, PIPE END	24
6	44-016-012	BRACKET, UPPER HANDRAIL	4
7	44-024-055	GUARD, HANDRAIL, STEPS, 52 3/8" LG.	4
8	44-024-058	GUARD, HANDRAIL, UPPER, 54 7/8" LG.	2
9	44-024-170	GUARD, HANDRAIL, MIDRAIL, 51 7/8" LG.	2
10	11110	HEX BOLT, GRADE A, ZINC FINISH, 3/8"-16 X 1 3/4"	8
11	37024	NYLON INSERT LOCK NUT, GRADE 2, ZINC FINISH, 3/8"-16	24
12	23307	SOCKET HEAD CAP SCREW, 3/8 - 16 x 1 1/4 LG.	12
13	23309	SOCKET HEAD BOLT, 3/8 - 16 UNC x 1 1/2" LG.	4
14	25537	3/8 - 16 x 3/8 CUP-POINT SET SCREW	8

# Exploded View & Bill of Materials: COL-6-56-14-HDG

44-006-740

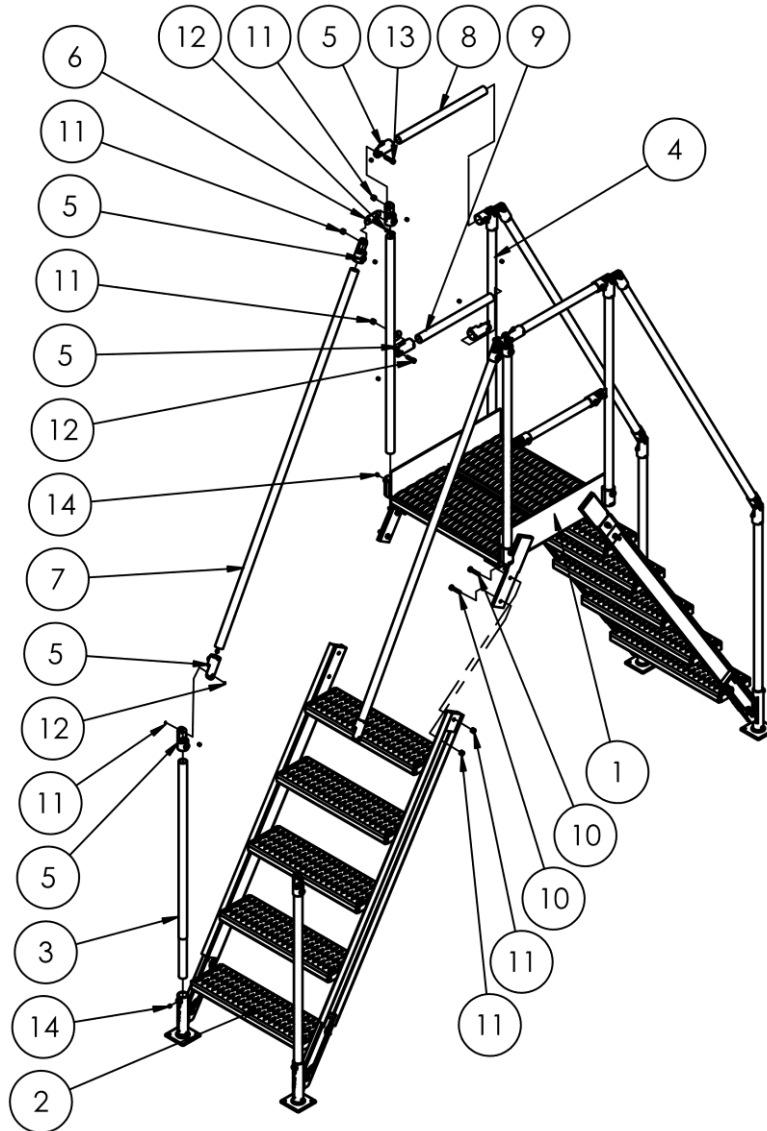

ITEM	PART NUMBER	DESCRIPTION	QTY.
1	44-513-010	WELDMENT, FRAME, PLATFORM	1
2	44-514-048	WELDMENT, FRAME, STEPS	2
3	44-024-066	GUARD, HANDRAIL, UPRIGHTS, 40 7/8" LG.	4
	44-024-361	COL-6-56-14-HDG	4
4	44-524-031	GUARD, WELDMENT, UPRIGHT, COL	4
5	44-516-016	ASSEMBLY, HANDRAIL, PIPE END	24
6	44-016-012	BRACKET, UPPER HANDRAIL	4
7	44-024-054	GUARD, HANDRAIL, STEPS, 64 1/8" LG.	4
8	44-024-061	GUARD, HANDRAIL, UPPER, 18 7/8" LG.	2
9	44-024-065	GUARD, HANDRAIL, MIDRAIL, 15 7/8" LG.	2
10	11110	HEX BOLT, GRADE A, ZINC FINISH, 3/8"-16 X 1 3/4"	8
11	37024	NYLON INSERT LOCK NUT, GRADE 2, ZINC FINISH, 3/8"-16	24
12	23307	SOCKET HEAD CAP SCREW, 3/8 - 16 x 1 1/4 LG.	12
13	23309	SOCKET HEAD BOLT, 3/8 - 16 UNC x 1 1/2" LG.	4
14	25537	3/8 - 16 x 3/8 CUP-POINT SET SCREW	8

# Exploded View & Bill of Materials: COL-6-56-23-HDG

44-006-741

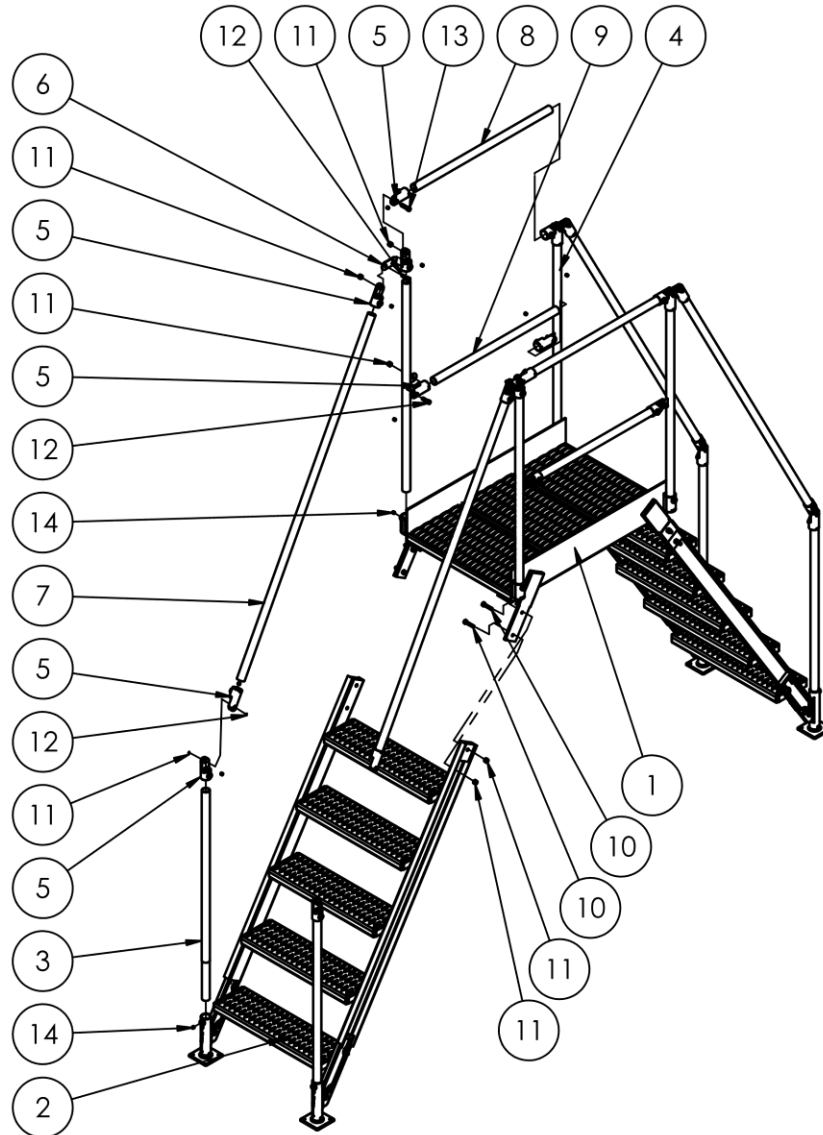

ITEM	PART NUMBER	DESCRIPTION	QTY.
1	44-513-011	WELDMENT, FRAME, PLATFORM	1
2	44-514-048	WELDMENT, FRAME, STEPS	2
3	44-024-066	GUARD, HANDRAIL, UPRIGHTS, 40 7/8" LG.	4
	44-024-361	COL-6-56-23-HDG	4
4	44-524-031	GUARD, WELDMENT, UPRIGHT, COL	4
5	44-516-016	ASSEMBLY, HANDRAIL, PIPE END	24
6	44-016-012	BRACKET, UPPER HANDRAIL	4
7	44-024-054	GUARD, HANDRAIL, STEPS, 64 1/8" LG.	4
8	44-024-060	GUARD, HANDRAIL, UPPER, 30 7/8" LG.	2
9	44-024-064	GUARD, HANDRAIL, MIDRAIL, 27 7/8" LG.	2
10	11110	HEX BOLT, GRADE A, ZINC FINISH, 3/8"-16 X 1 3/4"	8
11	37024	NYLON INSERT LOCK NUT, GRADE 2, ZINC FINISH, 3/8"-16	24
12	23307	SOCKET HEAD CAP SCREW, 3/8 - 16 x 1 1/4 LG.	12
13	23309	SOCKET HEAD BOLT, 3/8 - 16 UNC x 1 1/2" LG.	4
14	25537	3/8 - 16 x 3/8 CUP-POINT SET SCREW	8

# Exploded View & Bill of Materials: COL-6-56-33-HDG

44-006-742

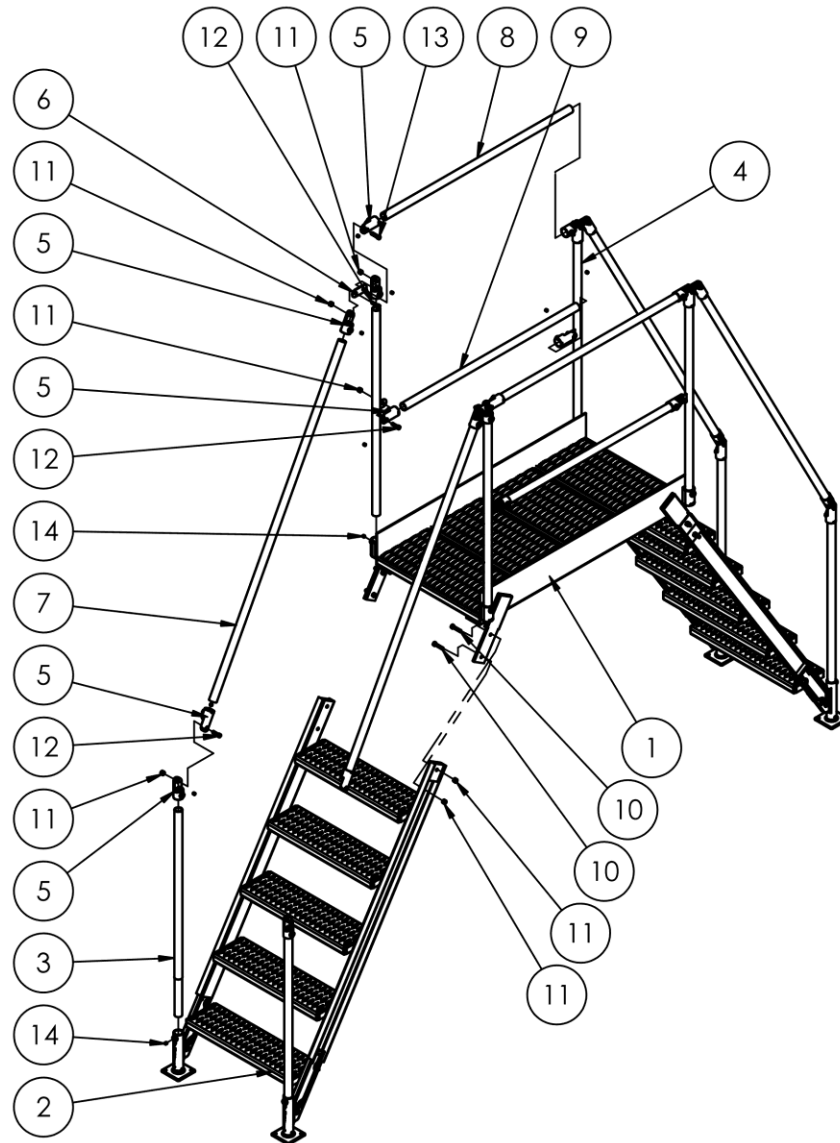

ITEM	PART NUMBER	DESCRIPTION	QTY.
1	44-513-012	WELDMENT, FRAME, PLATFORM	1
2	44-514-048	WELDMENT, FRAME, STEPS	2
3	44-024-066	GUARD, HANDRAIL, UPRIGHTS, 40 7/8" LG.	4
	44-024-361	COL-6-56-33 COL-6-56-33-HDG	4
4	44-524-031	GUARD, WELDMENT, UPRIGHT, COL	4
5	44-516-016	ASSEMBLY, HANDRAIL, PIPE END	24
6	44-016-012	BRACKET, UPPER HANDRAIL	4
7	44-024-054	GUARD, HANDRAIL, STEPS, 64 1/8" LG.	4
8	44-024-059	GUARD, HANDRAIL, UPPER, 42 7/8" LG.	2
9	44-024-063	GUARD, HANDRAIL, MIDRAIL, 39 7/8" LG.	2
10	11110	HEX BOLT, GRADE A, ZINC FINISH, 3/8"-16 X 1 3/4"	8
11	37024	NYLON INSERT LOCK NUT, GRADE 2, ZINC FINISH, 3/8"-16	24
12	23307	SOCKET HEAD CAP SCREW, 3/8 - 16 x 1 1/4 LG.	12
13	23309	SOCKET HEAD BOLT, 3/8 - 16 UNC x 1 1/2" LG.	4
14	25537	3/8 - 16 x 3/8 CUP-POINT SET SCREW	8

# Exploded View & Bill of Materials: COL-6-56-44-HDG

44-006-743

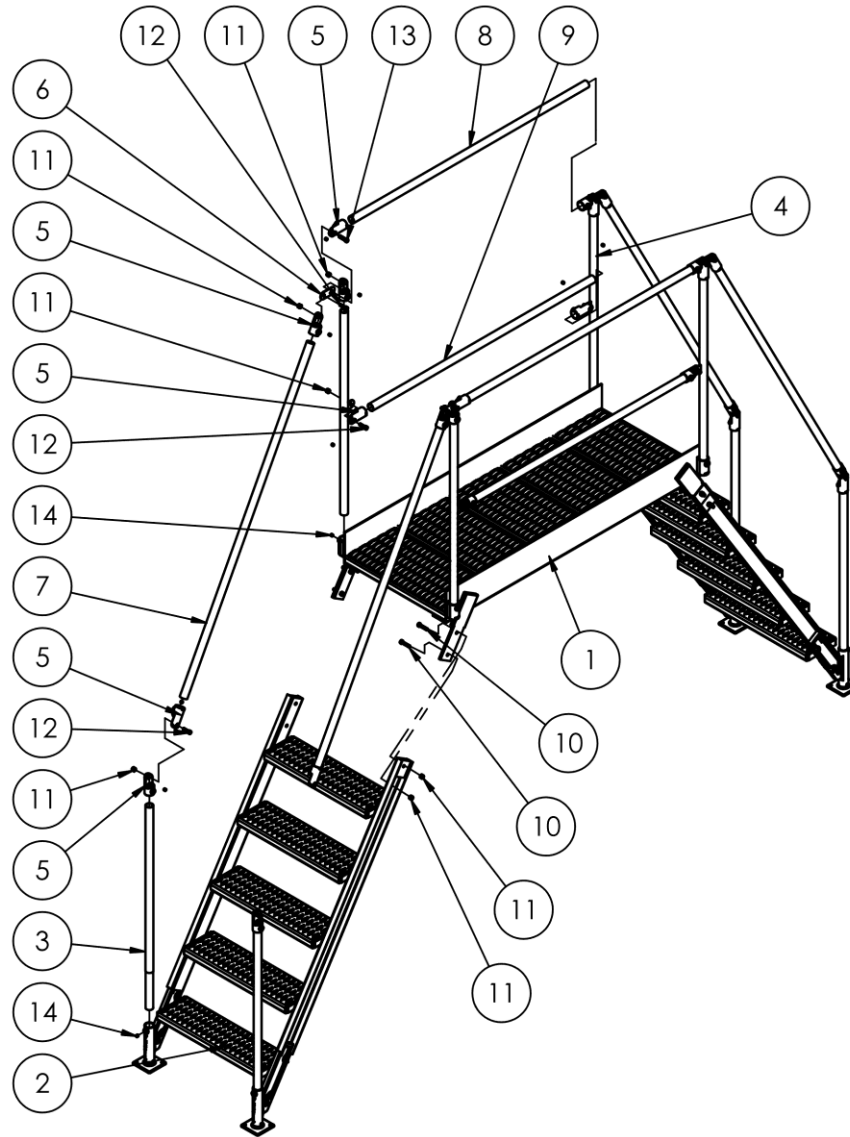

ITEM	PART NUMBER	DESCRIPTION	QTY.
1	44-513-013	WELDMENT, FRAME, PLATFORM	1
2	44-514-048	WELDMENT, FRAME, STEPS	2
3	44-024-066	GUARD, HANDRAIL, UPRIGHTS, 40 7/8" LG.	4
	44-024-361	COL-6-56-44-HDG	4
4	44-524-031	GUARD, WELDMENT, UPRIGHT, COL	4
5	44-516-016	ASSEMBLY, HANDRAIL, PIPE END	24
6	44-016-012	BRACKET, UPPER HANDRAIL	4
7	44-024-054	GUARD, HANDRAIL, STEPS, 64 1/8" LG.	4
8	44-024-058	GUARD, HANDRAIL, UPPER, 54 7/8" LG.	2
9	44-024-170	GUARD, HANDRAIL, MIDRAIL, 51 7/8" LG.	2
10	11110	HEX BOLT, GRADE A, ZINC FINISH, 3/8"-16 X 1 3/4"	8
11	37024	NYLON INSERT LOCK NUT, GRADE 2, ZINC FINISH, 3/8"-16	24
12	23307	SOCKET HEAD CAP SCREW, 3/8 - 16 x 1 1/4 LG.	12
13	23309	SOCKET HEAD BOLT, 3/8 - 16 UNC x 1 1/2" LG.	4
14	25537	3/8 - 16 x 3/8 CUP-POINT SET SCREW	8



## ASSEMBLING THE CROSSOVER LADDER

This crossover ladder is shipped in a disassembled state. Fasten each of the stairway segments to the platform/deck before installing the handrails. When assembly is finished, anchor the ladder to the ground. Numbers in parentheses correspond to part numbers in the exploded views and their bills of materials on pages 3-18.

**STEP 1:** Attach the stairways to the platform/deck with  $\frac{3}{8}$ "-16 hardware. There are 2 bolt holes at the top of each stairway and 2 bolt holes in each of the stairway brackets which are welded to the sides of the platform. Insert the bolts (11110) through the bolt holes in the stairway brackets and through the matching holes at the top of the stairways. Then apply a lock nut (37024) to the end of each bolt. Tighten all lock nuts.

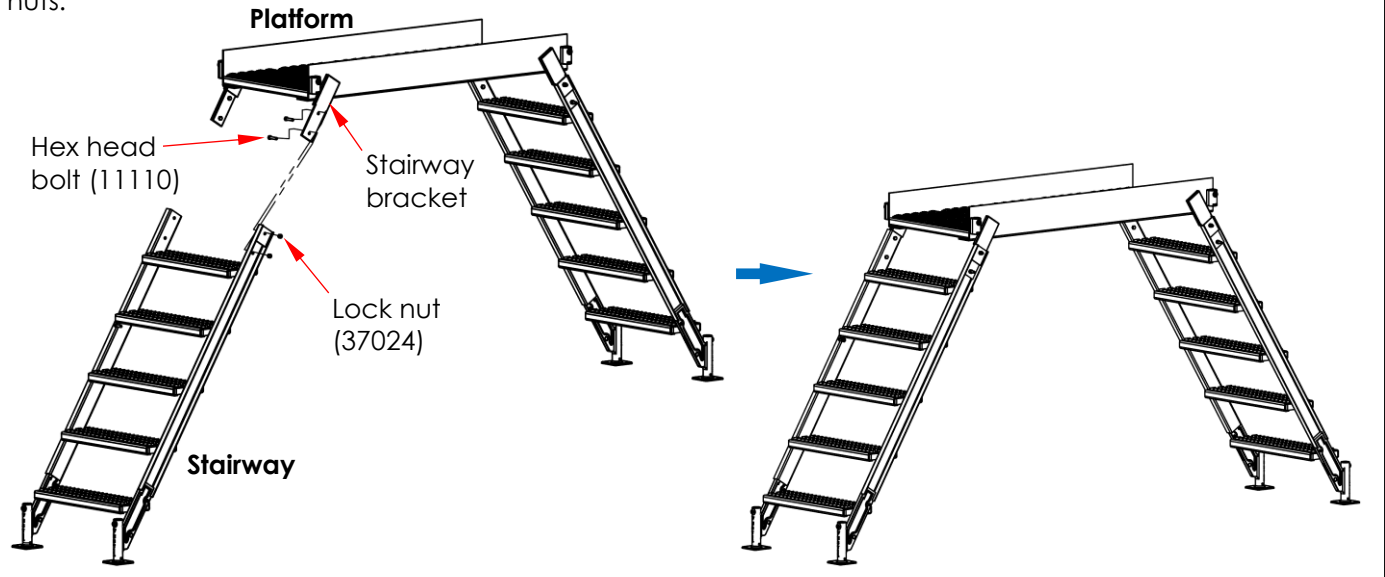

**STEP 2:** Attach pipe ends (44-016-012) to one end of the 4 **platform uprights** (44-524-031). If a pipe end won't fit over the end of an upright, loosen the set screw. Tighten all set screws to secure the pipe ends to the ends of the uprights. Attach a pipe end to one end of all 4 **handrail uprights** (44-024-066 or 44-024-361). Handrail uprights are  $40\frac{7}{8}$ " (40.875") long. Then, attach pipe ends to both ends of the upper handrails and both ends of the midrails. **NOTE 1:** Handrail and midrail dimensions are provided in the bill of materials for the *EXPLODED VIEW* of your COL model. Upper handrails are 3in. (~7.5cm) longer than midrails. **NOTE 2:** Pipe ends attached to **upper handrails** face opposite directions.

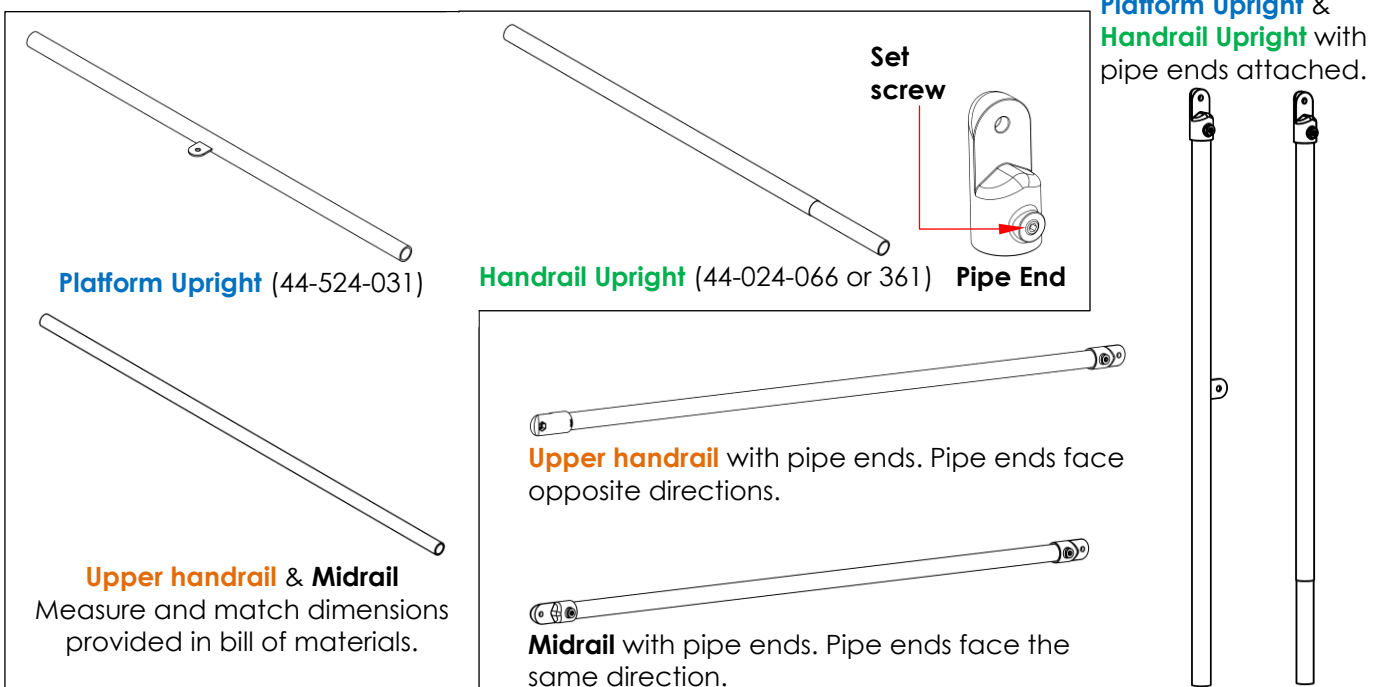

**STEP 3:** Install the **Platform Uprights** and **Handrail Uprights** into the appropriate sockets as shown in the diagram below. Make sure that the pipe ends face in the directions shown in the diagram as well. Leave socket set screws loose at this time.

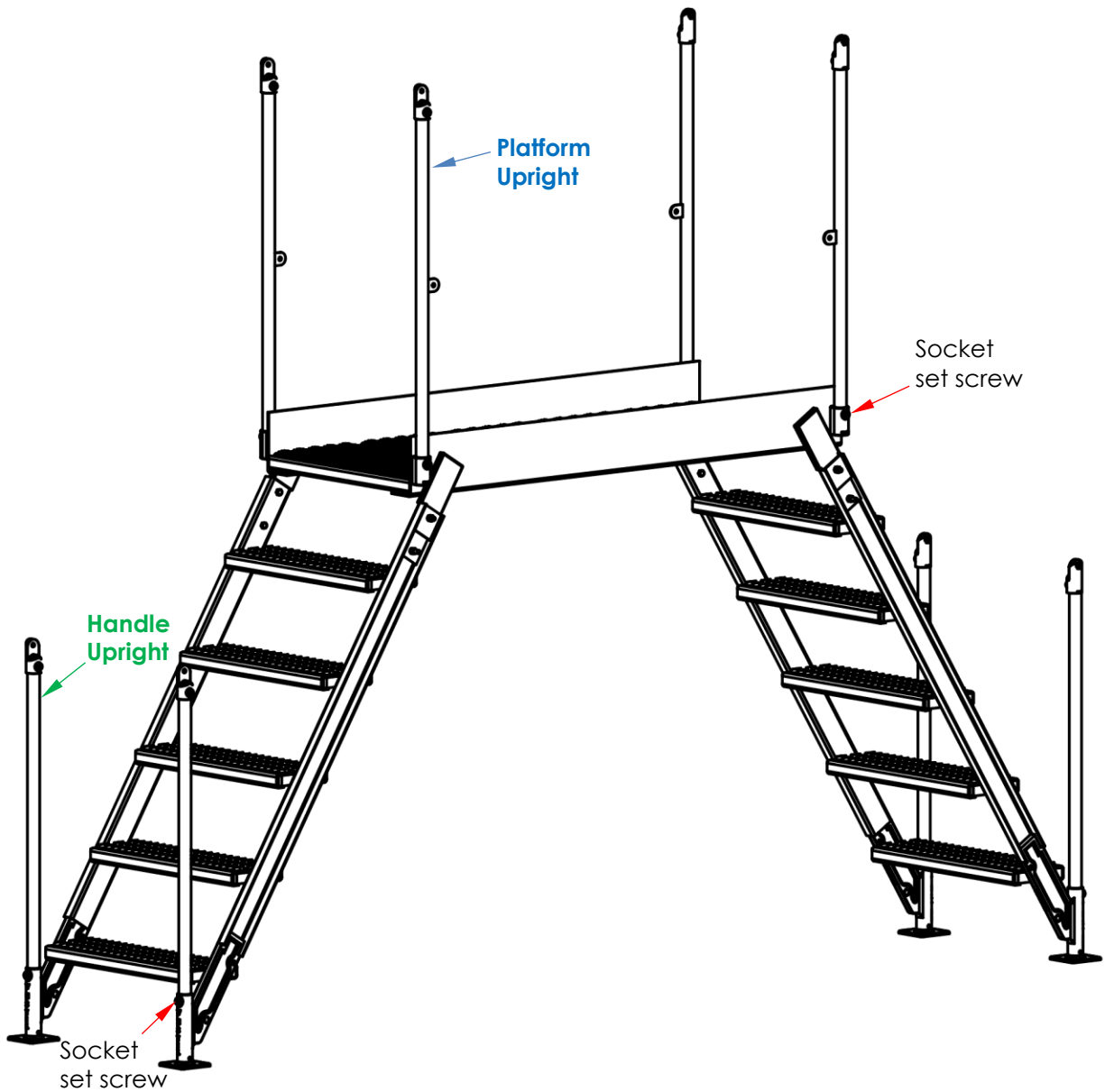

**STEP 4:** Attach midrails to the midrail brackets with 3/8"-16x1.25" socket cap screws and 3/8"-16 lock nuts.

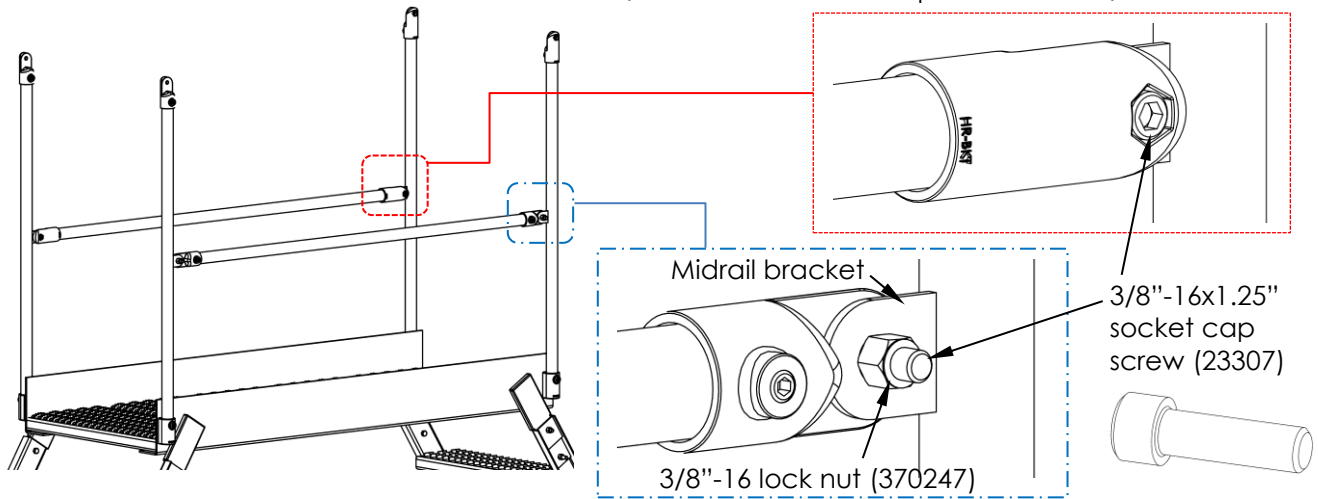

**STEP 5:** Insert 3/8"-16x1.5" socket head bolts (23309) through the pipe ends at the tops of the **Platform Uprights**. Slide one end of an upper handrail bracket onto each bolt. Attach **Upper Handrails** and **upper handrail brackets** (44-016-012) to the pipe ends with 3/8"-16 lock nuts (37024).

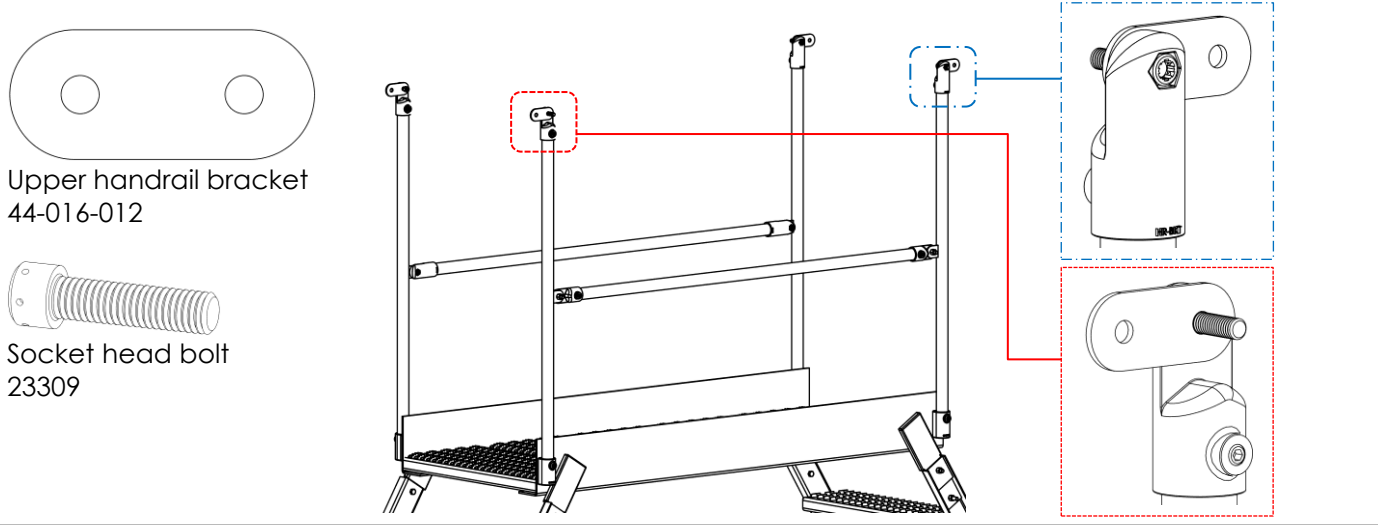

**STEP 6:** Attach **Upper Handrails** to the **Platform Uprights** by sliding the pipe ends at both ends over the socket head bolts (23309) installed in the previous step. Secure these connections with lock nuts (37024).

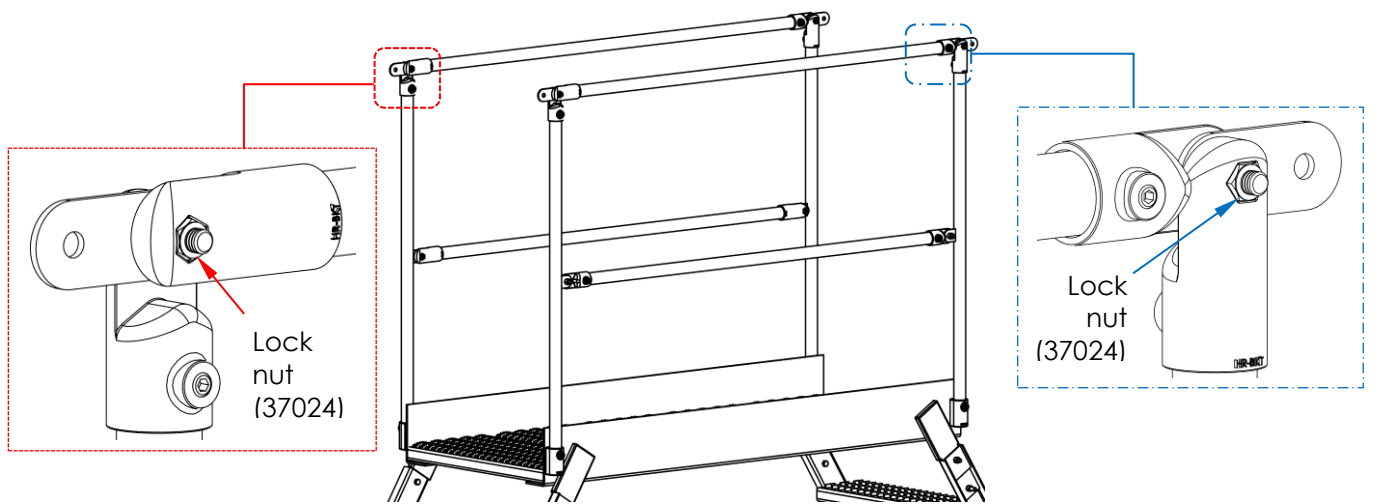

**STEP 7:** Attach handrails to the upper handrail brackets and to the handrail uprights with 3/8"-16x1.25" socket head cap screws (23307) and 3/8"-16 lock nuts (37024).

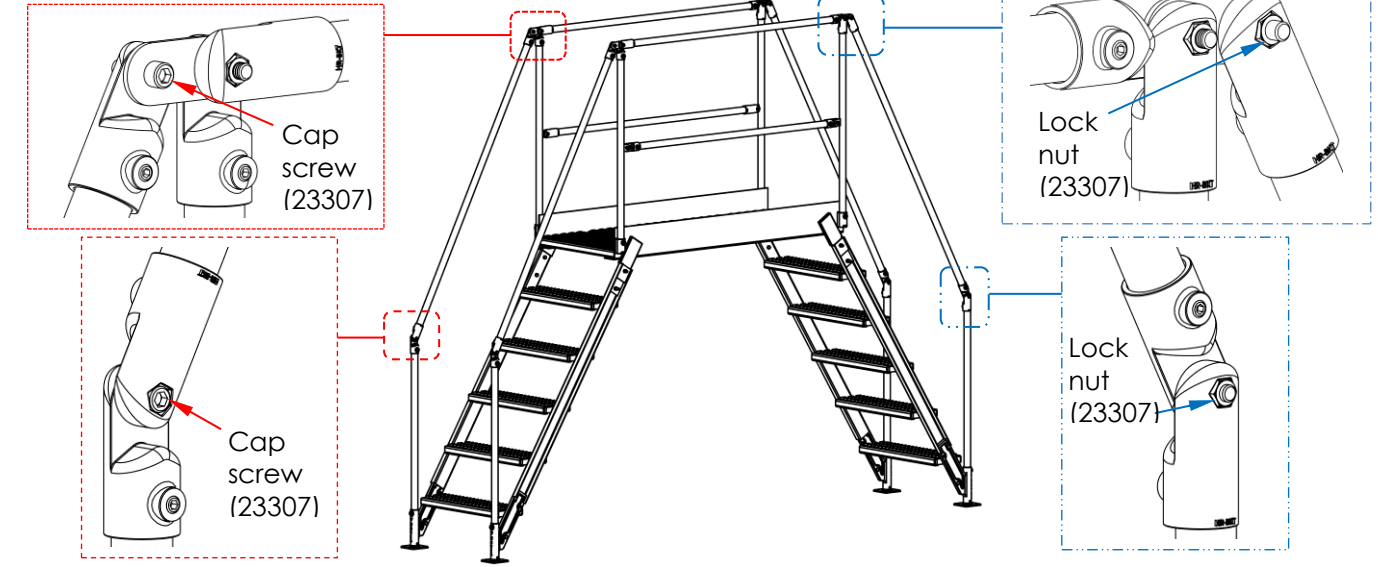

**STEP 8:** Tighten the socket set screws left loose in STEP 3.

**STEP 9:** Complete the installation of the crossover ladder by anchoring it to the floor. Concrete at the installation site must be intact, structurally sound, and well drained to prevent pooling of water. Select anchor bolts appropriate for surface conditions. Anchor bolt holes in the feet of the crossover ladder are 7/16" in diameter and will receive 5/16" diameter anchor bolts.

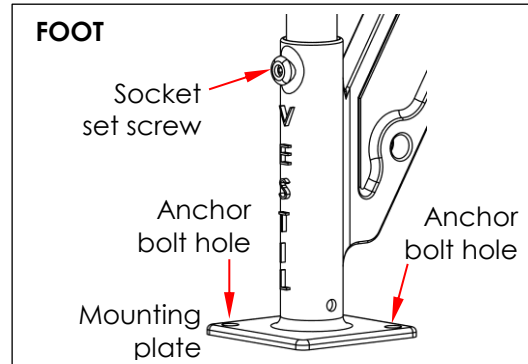

## RECORD OF SATISFACTORY CONDITION

After installing the crossover ladder and before using it for the first time, make a record of its condition and appearance. Thoroughly photograph the unit from multiple angles including all anchor points and all labels applied to it. Describe where each label is located. Collect all photographs and documents in a file. Mark the file appropriately to identify it. This file is a record of the crossover ladder in **satisfactory condition**. Compare the results of all inspections to this Record to determine if the unit is in satisfactory condition. Do not use it unless it is in satisfactory condition. Purely cosmetic changes, like damaged paint/powder coat do not constitute changes from satisfactory condition. However, touchup paint should be applied to all affected areas as soon as damage occurs to prevent rust from developing.

## INSPECTIONS AND MAINTENANCE

Proper maintenance is essential for maximizing the service life of the unit. If an inspection reveals any irregularities in the condition of the unit, repair it before returning it to service. Only use manufacturer-approved replacement parts. Contact **TECHNICAL SERVICE** if you have questions that are not addressed in these instructions, **or if you are uncertain how to address an issue** discovered during an inspection. Technical Service can be contacted by calling (260) 665-7586 and asking for the Service and Parts Department or by submitting questions online at <http://www.vestil.com/page-parts-request.php>.

Inspect and maintain the following components at least once per week as described:

### 1. Stairways:

- i. Examine the stairways for damage such as cracked metal, cracked welds, damaged rungs, significant rusting or corrosion, metal fatigue/pitting/erosion, and other forms of damage.
- ii. Repair damaged welds. Appropriately patch damaged metal.
- iii. Closely examine the feet/mounting plates and anchor points because they are in direct contact with the ground. Make sure that feet are free of significant rust and corrosion and that all anchor bolts are tightly fastened to the ground. Although hot dip galvanized COL crossover ladders can be installed outdoors, they should not be installed where water pools. Feet need to be kept dry whenever it is not raining or snowing.
- iv. Gently remove rust/corrosion and clean the affected areas. Apply touchup paint to the areas as soon as they dry. Apply touchup paint to all areas where the finish is damaged. Periodically clean dirt and debris from all surfaces—especially steps—to keep the finish in good condition. Slippery substances, such as grease and oil, must be cleaned from the steps as soon as contact occurs.

2. **Handrails, midrails, and uprights (platform and handrail):** Inspect all components of the railing system for punctures, bends, cracks, corrosion, rust, metal fatigue/pitting/erosion, and other damage. Closely examine all hardware (bolts, nuts, washers). Tighten loose connections. Replace damaged hardware.

3. **Labeling:** Make sure all labels are in place & in easily readable condition. See [LABELING DIAGRAM](#) on p. 23.

## LABELING DIAGRAM

Label content and location are subject to change so your product might not be labeled exactly as shown. Replace all labels that are damaged, missing, or not easily readable (e.g. faded). Order replacement labels by contacting the [TECHNICAL SERVICE AND REPLACEMENT PARTS DEPARTMENT](https://www.vestil.com/page-parts-request.php) online at <https://www.vestil.com/page-parts-request.php>. Alternatively, you may request replacement parts and/or service by calling (260) 665-7586 and asking the operator to connect you to the Parts Department.

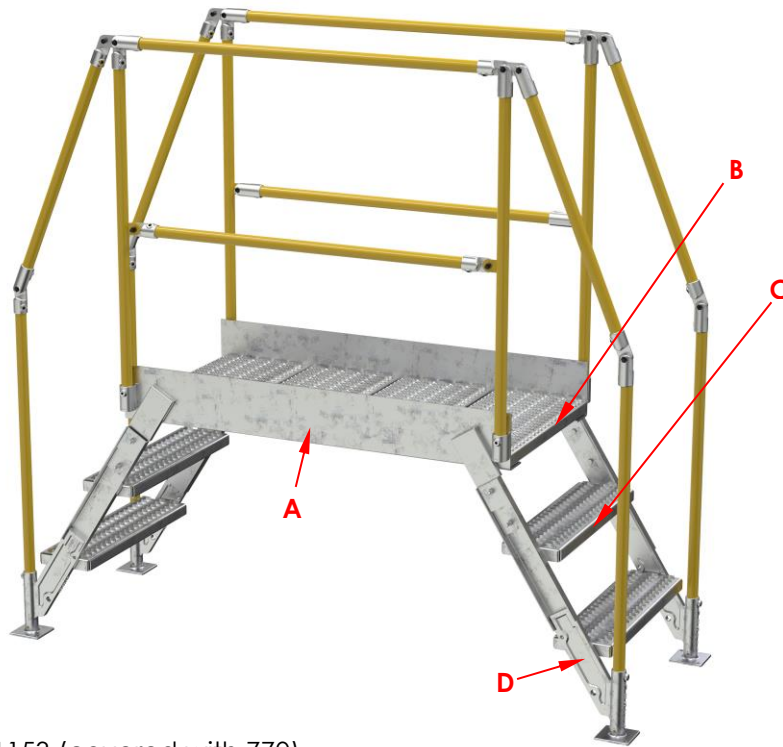

**A:** Label 1153 (covered with 770)

MODEL / MODÉLO / MODÈLE _____
WEIGHT / PESO / MASS _____
CAPACITY / CAPACIDAD / CAPACITÉ _____
SERIAL / SERIE / SÉRIE _____
UNITS: 2.2 lb. = 1kg      1" (or 1in.) = 2.54cm <b>1153</b>

**B:** Label 821 (both stairways; eye level or top step)

821 rev 01/20	<b>⚠ WARNING</b>
	Risk of serious injury or death. Read and understand entire owner's manual BEFORE using.

**C:** Label 740 (both stairways; on step below 821)

⚠ WARNING	⚠ ADVERTENCIA	⚠ AVERTISSEMENT
<ul style="list-style-type: none"> <li>• Do not use near live electric lines</li> <li>• Do not climb rails or lean over rails</li> <li>• Do not use if damaged or worn</li> <li>• Use ladder on level, smooth surfaces only</li> </ul>	<ul style="list-style-type: none"> <li>• No use cerca de líneas electricas</li> <li>• No se suba o se asome en la barandilla</li> <li>• No use si esta danado o gastado</li> <li>• Use la escalera en superficies a nivel y lisas</li> </ul>	<ul style="list-style-type: none"> <li>• Ne pas utiliser près des lignes électriques sous tension</li> <li>• Ne pas grimper sur ou vous pencher des rails</li> <li>• Ne pas utiliser si endommagée ou usagée</li> <li>• Utiliser l'échelle seulement sur des surfaces plates et lisses</li> </ul>

**D:** Label 204 (both stairways close to foot)

⚠ WARNING	⚠ ADVERTENCIA	⚠ AVERTISSEMENT
SECURE FRAME TO FLOOR	ASEGURE EL BASTIDOR AL PISO	FIXER SOLIDEMENT LE CADRE AU PLANCHER



## LIMITED WARRANTY

Vestil Manufacturing Company ("Vestil") warrants this product to be free of defects in material and workmanship during the warranty period. Our warranty obligation is to provide a replacement for a defective, original part covered by the warranty after we receive a proper request from the Warrantee (you) for warranty service.

### Who may request service?

Only a warrantee may request service. You are a warrantee if you purchased the product from Vestil or from an authorized distributor AND Vestil has been fully paid.

### Definition of "original part"?

An original part is a part used to make the product as shipped to the Warrantee.

### What is a "proper request"?

A request for warranty service is proper if Vestil receives: 1) a photocopy of the Customer Invoice that displays the shipping date; AND 2) a written request for warranty service including your name and phone number. Send requests by one of the following methods:

<u>US Mail</u>	<u>Fax</u>	<u>Email</u>
Vestil Manufacturing Company 2999 North Wayne Street, PO Box 507 Angola, IN 46703	(260) 665-1339 <u>Phone</u> (260) 665-7586	<a href="mailto:info@vestil.com">info@vestil.com</a> Enter "Warranty service request" in the subject field.

In the written request, list the parts believed to be defective and include the address where replacements should be delivered. After Vestil receives your request for warranty service, an authorized representative will contact you to determine whether your claim is covered by the warranty. Before providing warranty service, Vestil will require you to send the entire product, or just the defective part (or parts), to its facility in Angola, IN.

### What is covered under the warranty?

The warranty covers defects in the following original, dynamic parts: motors, hydraulic pumps, motor controllers, and cylinders. It also covers defects in original parts that wear under normal usage conditions ("wearing parts"), such as bearings, hoses, wheels, seals, brushes, and batteries.

### How long is the warranty period?

The warranty period for original dynamic components is 90 days. For wearing parts, the warranty period is 90 days. Both warranty periods begin on the date Vestil ships the product to the Warrantee. If the product was purchased from an authorized distributor, the periods begin when the distributor ships the product. Vestil may, at its sole discretion, extend a warranty period for products shipped from authorized distributors by up to 30 days to account for shipping time.

### If a defective part is covered by the warranty, what will Vestil do to correct the problem?

Vestil will provide an appropriate replacement for any covered part. An authorized representative of Vestil will contact you to discuss your claim.

### What is not covered by the warranty?

The Warrantee (you) is responsible for paying labor costs and freight costs to return the product to Vestil for warranty service.

### Events that automatically void this Limited Warranty.

- Misuse;
- Negligent assembly, installation, operation or repair;
- Installation/use in corrosive environments;
- Inadequate or improper maintenance;
- Damage sustained during shipping;
- Collisions or other accidents that damage the product;
- Unauthorized modifications: Do not modify the product IN ANY WAY without first receiving written authorization from Vestil.

### Do any other warranties apply to the product?

Vestil Manufacturing Co. makes no other express warranties. All implied warranties are disclaimed to the extent allowed by law. Any implied warranty not disclaimed is limited in scope to the terms of this Limited Warranty. Vestil makes no warranty or representation that this product complies with any state or local design, performance, or safety code or standard. Noncompliance with any such code or standard is not a defect in material or workmanship.

