

WARNING

Before putting tool in service, take the manual to your supervisor.



RENFROE™

MODEL M CLAMP

APPLICATION, OPERATION, AND MAINTENANCE MANUAL





Model M Clamp Operator's Manual

This Operator's Manual covers the application, operation, and maintenance of this RENFROE™ product. Operator's Manuals for other current RENFROE products are available upon request.



The RENFROE brand has been trusted and preferred by international lifting clamp users for more than 50 years. They are manufactured by The Caldwell Group, Inc. in Rockford, IL, and sold via a worldwide network of stocking distributors who exemplify the same high-quality performance and service standards RENFROE brand stands for.

The Caldwell Group, Inc.

200 State Street
Beloit, WI 53511
800.628.4263
815.229.5667
caldwellinc.com

Copyright © 2024 Caldwell Group

Table of Contents

Clamp Operation Do's and Don'ts	4
Definitions	6
Application	11
Operation	12
Maintenance & Inspection	18
Parts Diagram	24
RENFROE Ad	25
Notes	26

WARNING

Prior to selection, operation, and/or maintenance of RENFROE products, read and understand the information provided in this manual.

The understanding and use of the definitions are important in determining the limitations and proper application of RENFROE products.

Failure to review and utilize recommended applications, operation, and maintenance instructions may result in serious injury to operator and others.

Notice of Exclusion of Warranty

RENFROE has herein set forth in conspicuous language an exclusion of any warranty either expressed or implied, which is not specifically and particularly contained herein. Please refer to that statement for representations and warranties of products manufactured by RENFROE.

This publication supersedes all previously published and/or distributed information by manufacturer and/or its distributors with respect to applicable RENFROE products and subject matter described or contained herein.

RENFROE™ Clamp Operator

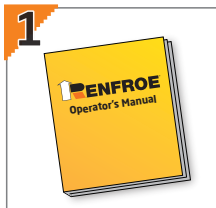

DO read and understand the Operator's Manual before using clamp.



DON'T use a connection that may release the clamp.



DO consult the Operators Manual or RENFROE when in doubt.

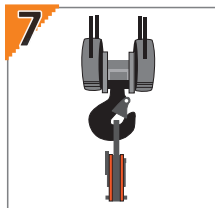

DON'T attach clamp directly to crane hook or use a heavy flexible connection.

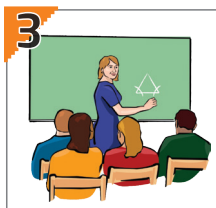

DO attend a RENFROE factory training class to establish proper clamp use.



DO use a flexible connection between crane hook and clamp shackle.

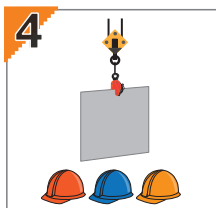

DON'T lift over workers, safety areas, or personnel.

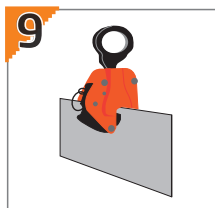

DO use correct clamp for job; **DON'T** use large capacity clamps to lift light loads.



DO lock clamp closed with lock; **DON'T** lift with lock in open position.



DO use clamps within their rated capacity; **DON'T** overload clamps.

Operation Do's and Don'ts

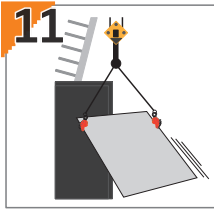

11 **DO** use enough clamps to balance load; **DON'T** lift loads that are not balanced.

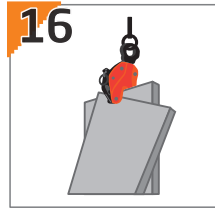

16 **DON'T** rush—and **DON'T** lift more than one plate at a time with a vertical clamp.



12 **DO** always refer to pre-lift inspection in Operator's Manual.

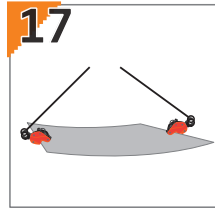

17 **DON'T** lift plate horizontally with a vertical lift only clamp.



13 **DO** inspect clamp before each lift and follow inspection & maintenance instructions.



18 **DON'T** alter the clamp; **DON'T** grind, weld or modify the clamp in any manner.

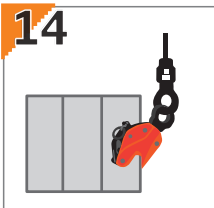

14 **DON'T** side load with a straight shackle clamp.



19 **DO** secure load before attaching clamp.

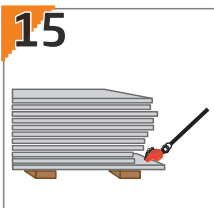

15 **DON'T** misuse (i.e. **DON'T** lift plate from bottom of plate stack).



20 **DO** use only RENFROE replacement parts to assure proper operation of the clamp.

Vertical Lift

The lifting of a single plate or member in which the lifting force exerted by the rigging is directly above and in line with the lifting shackle as shown in the illustration on the right.

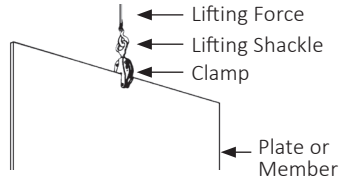

Vertical Turn/Lift

A vertical turn/lift clamp is a vertical lifting clamp specifically intended to turn a single plate or member through a ninety degree (90°) arc and back to vertical through the same ninety degree (90°) arc or from horizontal to vertical to horizontal through a one hundred and eighty degree (180°) arc. Refer to Application Section of specific Turn/Lift clamps for further detail. During the turning operation, the edge of the plate opposite the edge to which the clamp is attached should always be in contact with a supporting surface such as a factory floor and the load on the clamp not exceed one half rated capacity of clamp—refer to illustrations shown below.

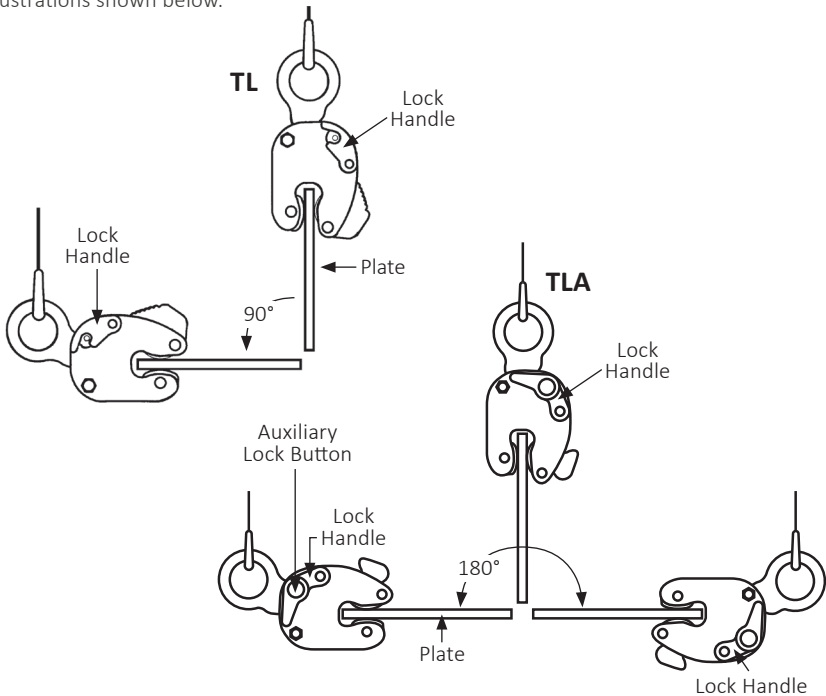

Horizontal Lift

Clamps (used in pairs or multiples) are attached to the side edges of a plate or bundle of plates positioned horizontally to the floor level. The rigging attached to clamps is generally multi-legged slings with the connecting point of the slings being approximately centered between the distance separating the clamps. Refer to illustrations shown on the right. **WARNING: The capacity of all horizontal clamps is based on a sling angle of sixty degrees (60°). Sling angles less than sixty degrees (60°) increase the load exerted on the clamps. Never exceed the rated capacity of a single clamp.**

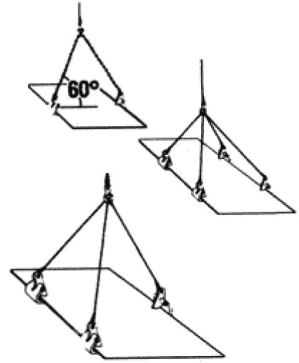

Steel Plates

Unless otherwise specified, lifting clamps are manufactured to handle hot-rolled steel plates whose Brinell Hardness does not exceed 300. **WARNING: Do not lift plates with coatings or mill scale that prevent the gripping surfaces of the clamp from making positive contact with the base metal.**

Finished and Polished Plates

Steel plates in this category have other than hot-rolled surfaces such as stainless steel, etc., and are generally handled using non-marring clamp that incorporate smooth-gripping surfaces. **WARNING: For applications using clamps with serrated gripping surfaces on finished or polished plates, secure written recommendations from CALDWELL/RENFROE.**

Structural Members Fabricated Sections

Unless otherwise specified, clamps described as capable of handling structural members and fabricated sections are limited to hot-rolled steel whose Brinell Hardness does not exceed 300. **WARNING: For applications not covered by the above information, secure written recommendations from CALDWELL/RENFROE.**

For applications not covered by the above information, secure written recommendations from CALDWELL/RENFROE.

Rated Capacity

The rated capacity of a RENFROE product is based on the product being in “new or as new” condition and represents the maximum load the product is to be subjected to when utilized in the manner described in this manual. Wear, misuse, abuse, and other factors relating to usage may reduce the rated capacity. Shock loading and the factors listed must be taken into consideration when selecting a RENFROE product for a given application.

Jaw Opening

The minimum and maximum plate/wall thickness a clamp specified for handling plates is capable of lifting. **WARNING: Never use a clamp for lifting a plate where the plate/wall thickness is less than or greater than the minimum and maximum stenciled on the clamp.**

Operating Temperatures

Unless specified under the Application Section of the individual model, the approved operating temperature of RENFROE clamps is from 0°F (-18°C) to a maximum of 200°F (93°C). The minimum and maximum temperatures apply to both ambient and the material being handled by the clamp. **WARNING: Secure written authorization from CALDWELL/RENFROE before using clamps in temperatures other than shown.**

Hot Lifts

The Model R and S clamps are available in modifications that are capable of making lifts where the temperatures of the member being lifted exceeds 200°F (93°C). Depending on conditions, a lift may exceed 1000°F (538°C). The exact application and temperatures of the plates to be handled are critical in selecting the proper mode. **WARNING: Secure written instructions from CALDWELL/RENFROE for all hot lift applications.**

Locking Clamps

Locking clamps are divided into the categories listed below. With the exception of the “Locking Wedge” and “Locking Screw” type, the purpose of the locks is to facilitate the attaching and removing of the clamp from the member being handled.

Lock Closed

An over-center, spring-loaded mechanism in which the spring exerts a force on the gripping cam when the lock handle is moved to the “Lock Closed” position. When the handle is moved to unlocked position, the force exerted by the spring is relaxed and the gripping cam may be retracted by pushing the lifting shackle into body of clamp. Refer to the Operation Section of specific models of “Lock Closed” clamps for additional details. Typical “Lock Closed” clamps are Models DG, FR, and M.

Lock Open Only

Normally used on “Hot Lift” clamps and consists of a manually operated “Lock Stop Pin” that is inserted when gripping cam of clamp is retracted and removed when clamp is positioned on the plate. Tag line may be used to permit operator to remove pin from a greater distance from clamp. Refer to the Operation Section of specific model of “Lock Open Only” clamps for additional details. A typical “Lock Open Only” clamp is the Model RO.

Lock Closed-Lock Open

An over-center, spring-loaded mechanism in which the spring exerts a force on the gripping cam when the lock handle is moved to the “Lock Closed” position. When the handle is moved to the “Lock Open” position, the gripping cam is maintained in the retracted position for ease in installing the clamp on a plate or member. The Model FRD contains individual “Lock Open” and “Lock Closed” mechanisms that must be operated separately. Refer to the Operation Section of specific models of the “Lock Open-Lock Closed” clamps for additional details. Typical “Lock Open-Lock Closed” clamps are Models FRD, R, S, SD, SEA, SX, TL, TLA, TLC, and the J Series.

Locking Wedge

Locking wedge is a fluted steel wedge that is driven in place with a hammer. The body of the wedge is positioned in a slot in the clamp body with the fluted edges contacting the member to which the clamp is being attached. Refer to Operation Section of specific models of the “Locking Wedge” clamps for additional details. Typical “Locking Wedge” clamps are Model A1, B1, B2, and PB.

Locking Screw

“Lock Screw” clamps depend on manually adjusting a screw to hold the gripping surface in place for lifting and removing the clamp from member being lifted. Refer to Operation Section of a specific model of “Locking Screw” clamps for additional details. Typical “Locking Screw” clamps are Models AC, ACP, NM, PC, SCP, and SCPA.

Non-Locking

“Non-Locking” clamps have no mechanisms to aid in attaching or removing clamp from member being lifted. It is necessary to have position of clamp maintained on the member being lifted until a properly applied force is exerted to the lifting shackle. Refer to Operation Section of specific models of the “Non-Locking” clamps for additional details. Typical “Non-Locking” clamps are Model AST, ASTL, BD, LHC, LHD, and WHSR.

Warning

A pointing out and notice of danger. The purpose of a “WARNING” is to apprise the operator and all other affected persons of the existence of danger of which they should be but may not be aware and to enable the operator to protect themselves and others where applicable against such danger. An attempt is made herein to warn against reasonable and reasonably foreseeable danger in the proper use and possible reasonable misuse of CALDWELL/ RENFROE products described in this manual.

Designated Person

A person selected by the employer or the employer’s representative as being competent to perform those specific duties.

Qualified Person

A person who, by possession of a recognized degree in an applicable field or certificate of professional standing, or who, by extensive knowledge, training, and experience, has successfully demonstrated the ability to solve problems relating to the subject matter at hand.

Model M Horizontal Lifting Locking Clamp Series

The Model M is a multipurpose clamp used for positioning, sorting, erecting and handling of prefabricated sections. The split lower jaw enables the clamp to be particularly useful in handling structural shapes. It incorporates a “Lock Closed” feature which facilitates attaching the clamp to the member being lifted and makes it an ideal horizontal locking plate clamp. Refer to Definitions for explanation of “Lock Closed” clamp. It is recommended for use in pairs and sets of pairs. Refer to illustrations.

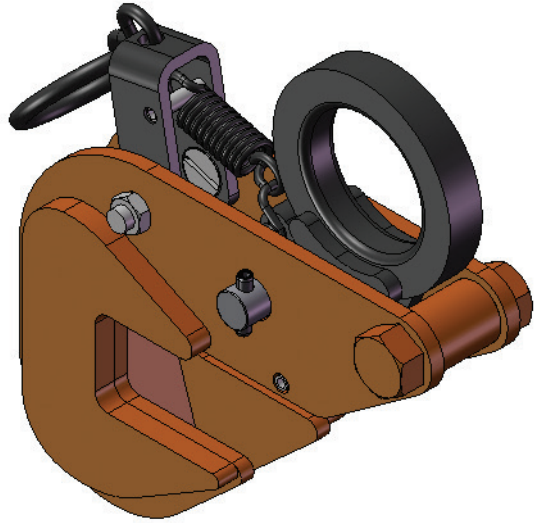

For an exploded view of the clamp parts, turn to page 24. **WARNING: Refer to the sections on Operation and Maintenance for the approved procedures in the operation and maintenance of this product.**

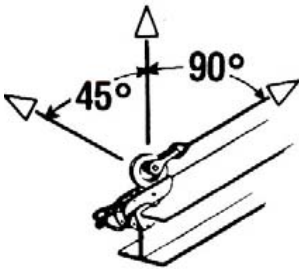

As shown, the Model M is capable of accepting lift from angles shown.

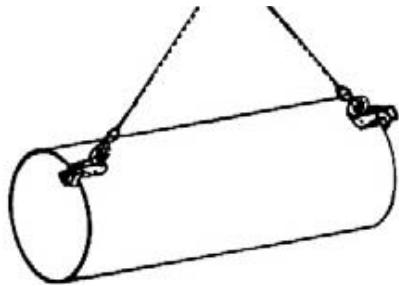

Cylindrical Shapes

Model M Horizontal Lifting Locking Clamp Series

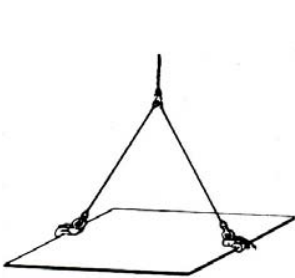
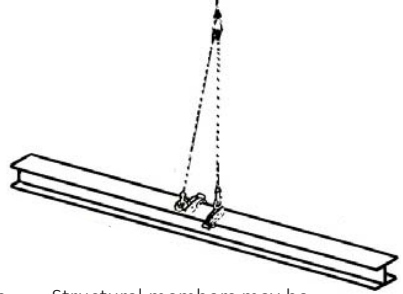

Plate steel can be handled horizontally using the Model M in pairs or sets of pairs.



Dished tank heads and other similar shapes may be handled with the Model M.



Structural members may be handled by gripping the flanges on opposing sides, assuring a level lift for the erection of steel.

STEP 1

Before using any RENFROE clamp, refer to the Application section to confirm the operation to be undertaken is an appropriate application for this product.

STEP 2

Select appropriate capacity and jaw opening. The model designation, capacity, and plate thickness are stenciled on each clamp. **WARNING: Never exceed rated capacity or use on material whose thickness is not within the range of jaw opening stenciled on clamp.**

Always use clamps with maximum jaw openings and rated capacities that are nearly equal to the thickness and weight of the sections being lifted.

STEP 3

Inspect clamp before each lift. **WARNING: Do not use if in need of repair.**

If in doubt, refer to the Maintenance section for detailed maintenance instructions and exploded view of the clamp for part identification. **WARNING: ONLY a single sagging plate may be lifted with this clamp. Sagging plate shall not exceed 45° angle. See the illustration here.**

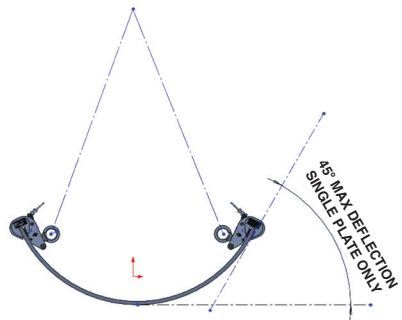

Only clamps designed with gripping teeth on the cam shall be used when lifting sagging plate.

NON-MARRING clamps (clamps with no teeth on the cam) shall not be used for this operation.

Do not attempt to lift a stack of sagging plates. **WARNING: Always use an adequate number of clamps to assure a balanced load. Never use on bundle of plates that are not able to support themselves without sagging or stacked without edges being even.** See illustration.

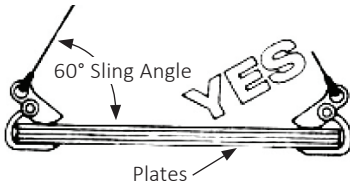

SELF-SUPPORTING LOAD

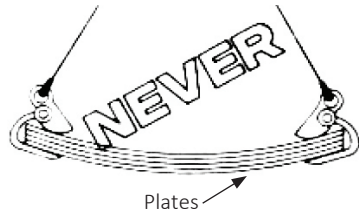

SAGGING LOAD

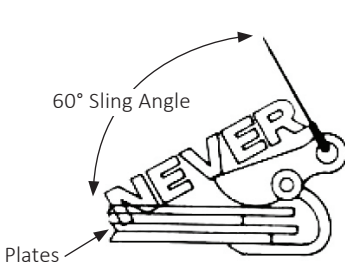

EDGES UNEVEN

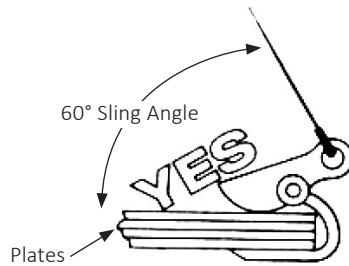

EDGES EVEN

- A. Check the clamp to be certain the identification and warning tags are present and legible.
- B. Do not use the clamp if the tags are missing or illegible.
- C. Inspect gripping surfaces for wear and defects. Gripping surfaces must be sharp and free of foreign matter.
- D. Inspect condition of body for wear, damage, and distortion, particularly in the area of the jaw opening.
- E. Inspect lifting shackle and all pin holes for wear and damage.
- F. The lock springs must have a definite amount of tension when the lock is moved to the "Lock Closed" position without material in the clamp.
- G. Remove any clamp from service in need of repair.

STEP 4

A clamp is a component of the rigging used in lifting or transporting a member. It is important to use safe and adequate rigging. The lock is used to hold the clamp in place until the gripping mechanism is actuated by a force applied to the lifting shackle. **WARNING: Improper or excessively heavy rigging may interfere with the operation of the clamp and its ability to maintain a proper position on the plate. Never attach crane hook directly to the clamp—always use a flexible sling between crane hook and clamp.**

STEP 5

Move lock lever to “Open” position. Refer to illustration below.

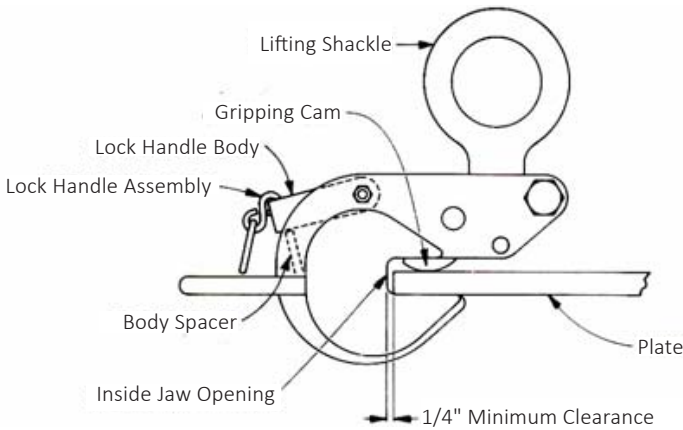

"LOCK CLOSED" POSITION

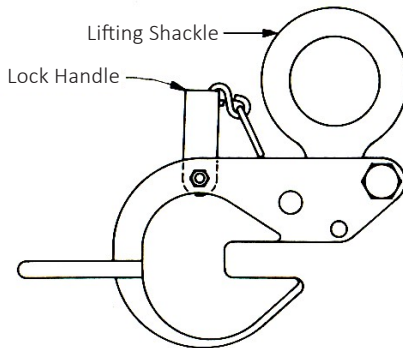

"OPEN" POSITION

STEP 6

Position clamp on plate to be lifted. Do not allow inside of jaw opening to rest on edge of plate. Maintain 1/4" clearance. Refer to "Open" position illustration in Step 5.

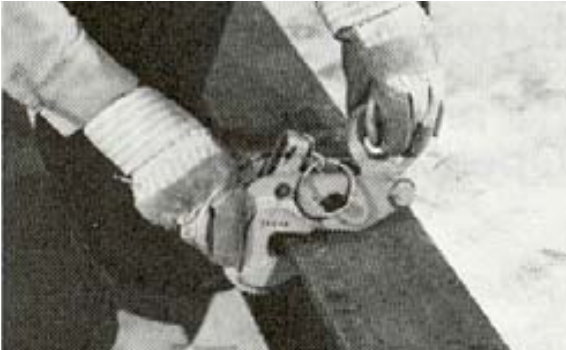

STEP 7

Position clamp so direction of force applied by the crane is in line with the lifting shackle. See YES and NEVER examples that follow. **WARNING: Never exceed 10° side loading.**

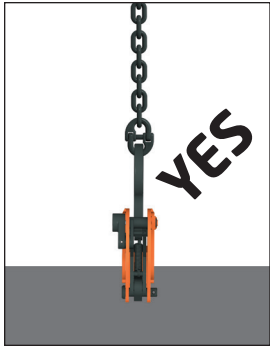

Sling directly above and in-line with the lifting shackle.

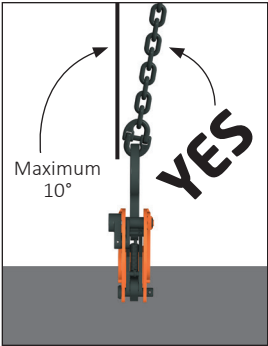

Maximum allowable side loading.

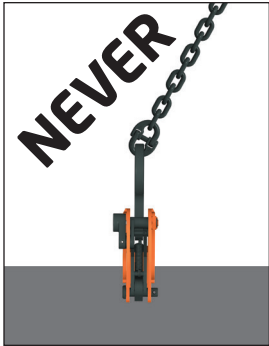

Excessive side loading.

STEP 8

Make certain the lower jaw and gripping cam are fully in contact with the plate and not partially on and off the edge of the plate.

STEP 9

Move lock handle to "Lock Closed" position. Lock handle body must rest on body spacer. Spring now exerts force on gripping cam. See illustration of "Locked Closed" position in Step 5.

STEP 10

Commence lift. **WARNING: The operator should position himself away from and fully clear of the member to be lifted. Do not commence lift until all personnel are clear of the area of the lift. Never stand under or near a member being lifted.**

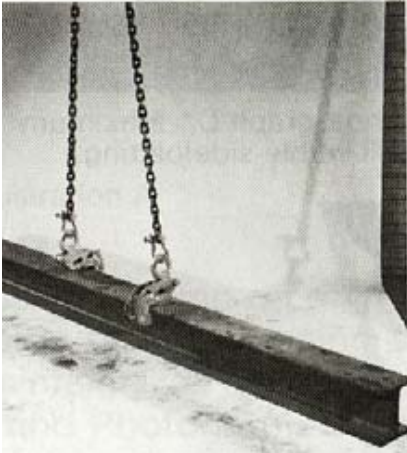

STEP 11

To remove clamp after plate is fully supported and at rest in a stable position, relax lifting force, move lock handle to "Open" position, and lift clamp from plate. Refer to "Open" position illustration in Step 5.



STEP 12

Inspect clamp. Remove from service if in need of repair. **WARNING: In the event the stenciling is worn and not legible or the tag containing the model, capacity or other pertinent information is missing—do not use clamp until it has been properly labeled.**

Inspection kits are available from the distributor or RENFROE. Kit contains:



RENFROE clamps are constructed so the wearing parts may be replaced by using the RENFROE Repair Kits. Kits contain all parts generally replaced due to normal wear. To order a repair kit, talk to your distributor or call us at 800.628.4263 or 815.229.5667.



Model M Horizontal Lifting Locking Clamp Series

The severity of service to which the clamp is subjected in the workplace determines the frequency and type of inspection procedure required for the clamp. The frequency and type of inspection is determined by the clamp owner. RENFROE acknowledges the ASME B30.20 safety standard which sets forth minimum inspection requirements for “Below-the-Hook” lifting devices and the RENFROE Recommended Inspection Schedule meets and/or exceeds the ASME inspection recommendations.

Before using a clamp, operators should be trained by a qualified person to visually inspect a lifting clamp that will include, but not be limited to, the following:

Every-Lift Inspection:

A visual inspection by the operator before and after each lift made by the clamp.

- Check the clamp to be certain the identification and warning tags are present and legible.
- Do not use the clamp if the tags are missing or illegible.
- Inspect gripping surfaces for wear and defects—gripping surfaces must be sharp and free of foreign matter.
- The lock spring must have a definite amount of tension when the lock is moved to the “Lock Closed” position without material in the clamp.
- Inspect the condition of the body for wear, damage, and distortion, particularly in the area of the jaw opening.
- Inspect lifting shackle and all pin holes for wear and damage.
- Remove any clamp from service in need of repair.



Choose Factory Refurbish & Recertification

Do you currently offer clamp refurbishing and recertifications? Count on CALDWELL/RENFROE to handle refurbishments in total for you or to supplement your in-house capabilities. To begin the quote process or learn more about the program, call our customer service department. We'll explain how things work and get you started right away. If requested, we can also provide a certificate of proof test. **Call us at 800.628.4263.**

WARNING: Do not use the clamp if in need of repair. If, during the Every-Lift Inspection, the operator believes the clamp exhibits excessively worn parts or is damaged, the clamp should be inspected by a qualified person who will make a determination as to its fitness to make a lift. At this time, the condition of the clamp should be noted and recorded. After inspection by the qualified person, it may be decided that a periodic inspection procedure is necessary.

Frequent Inspection:

A visual inspection (see Every-Lift Inspection) by an operator or other designated person timed according to the clamps service class.

Normal Service	Monthly
Heavy Service	Weekly to Monthly
Severe Service	Daily to Weekly

If, during the frequent inspection, the operator believes the clamp exhibits excessively worn parts or is damaged, the clamp should be inspected by a qualified person who will make a determination as to its fitness to make a lift. At this time, the condition of the clamp should be noted and recorded. After inspection by the qualified person, it may be decided that a periodic inspection procedure is necessary.

Periodic Inspection:

A recorded inspection by a qualified person as described in the Periodic Inspection Procedure below timed according to the clamps service class.

Normal Service	Annual
Heavy Service	Semi-Annual
Severe Service	Quarterly

If during any inspection a condition is found which leads to a periodic inspection, then the next periodic inspection is due from the time the clamp is returned to service. See the table below.

Normal Service	1 Year
Heavy Service	6 Months
Severe Service	3 Months

WARNING: If any hazardous condition is found that may cause injury to the operator or other personnel, then the clamp should be subjected to a Periodic Inspection by a qualified person.

Repair (Replacement of Worn Parts):

During regular maintenance, when replacing parts that are worn, a record should be made of the parts replaced. After the replacement of worn parts, clamps need not be load tested if using RENFROE parts. Non-RENFROE parts are not approved and shall not be used.

Repair (Replacement of Damaged Parts):

During a repair in which parts are replaced due to damage, a record should be made of the repair. At this time, the clamp should be marked with the following information as per the ASME B30.20 requirements:

- Name and address of the repairer
- Repairer's unit identification
- Clamp weight (if altered)
- Rated load (if altered)
- ASME BTH-1 Design Category (if altered)
- ASME BTH-1 Service Class (if altered)

RFID

Some RENFROE clamps are fitted with an RFID chip and can be clearly identified by means of an ID number. This can be captured using the RUD ID EASY-CHECK® (reading device) and transferred to the EYE-D.NET system, for example. The latter application assists you in managing and documenting your components.

Further information can be found online or from your RENFROE contact.



RENFROE Clamps 101: Repair, Rebuild, or Replace?

Know your options when you find a lifting clamp that's showing wear on the CALDWELL blog here:

caldwellinc.com/blog

Model M Periodic Inspection Procedures

STEP 1

Verify the identity of the clamp by checking the identification plate on the clamp body. If the identification plate is missing or not legible, an RFID chip (Radio Frequency Identification Device) is embedded in the clamp body or a clamp component. If the identification plate is missing and the RFID chip is unavailable, call the factory for instructions on returning the clamp for recertification. **NOTE: Newer clamps with forged bodies will have the marking embossed on the clamp body. If this information is not legible, contact the factory for instructions on returning the clamp for recertification.**

STEP 2

Completely disassemble clamp.

STEP 3

Remove all dirt, grease, and other matter that may inhibit proper inspection of the clamp body or clamp components.

STEP 4

Body:

- A. Inspect the welds for fractures. RENFROE recommends a dye penetrate or similar method of detecting indications on the clamp. If an indication is found, it may be necessary to use a magnetic particle, ultrasonic, or similar methods for determining damage to the clamp or components.
- B. Inspect all load bearing pin holes for wear and elongation.
- C. Inspect inside jaw opening for displaced metal and distortion.
- D. Inspect cam stop pin. Pin must be in place. Refer to exploded view. **WARNING: Replace clamps containing fractures, elongated holes, distorted jaw openings and clamp bodies with metal in jaw opening displaced. Cam stop pin must be in place.**

STEP 5

Gripping Cam (M-1 in parts diagrams on page 24):

- A. Inspect gripping cam for chipped or worn teeth. Teeth must be sharp and free of foreign matter.
- B. Inspect cam for fractures and wear. **WARNING: Replace cams with fractures, chipped or worn teeth.**

STEP 6

Lifting Shackle (M-2 in parts diagrams on page 24):

- A. Inspect lifting shackle eye for elongation and wear at point where the eye engages the sling attachment.
- B. Inspect shackle pin holes for wear and elongation. The difference between the pin diameter and the hole should not exceed 10%.
- C. Inspect shackle body for bending.

An elongated shackle eye indicates overloading. Elongated shackle pin holes indicate wear and possible overloading. Bent shackle indicates excessive side-loading. **WARNING: Replace shackles that are bent, show excessive wear at eye, have elongated eye, or shackle pin holes.**

STEP 7

Lock Assembly and Lock Ring (M-3 and M-10 in parts diagrams on page 24):

- A. Inspect for damage and wear. Lock assembly should pivot freely without binding. When assembling lock body to clamp, tighten pivot screw lock nuts, then loosen until lock body pivots freely.
- B. Make certain locking ring is attached. **WARNING: Do not alter lock assembly. Use only component parts supplied by RENFROE. Replace lock if worn or damaged.**

STEP 8

Lock Spring and Spring Clip (M-4 and M-8 in parts diagrams on page 24):

- A. Inspect lock spring and lock spring clip for distortion. Spring must have a definite amount of tension when moved to the "Lock Closed" position without material in the clamp. Lock handle body must rest on body spacer. See illustration on the right. **WARNING: Replace if damaged, distorted, or lacking in tension.**

- B. The spring clip mounts on a spiral pin passing through the gripping cam and through the end loop of the lock spring. Check to make certain the spiral pin and loop are not damaged or distorted. Refer to exploded view.

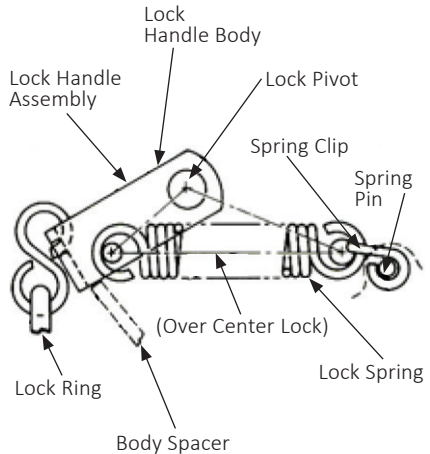

"LOCK CLOSED" POSITION

STEP 9

Shackle Pin and Cam Pin (M-5 and M-6 in parts diagrams on page 24):

- A. Inspect all pins for:
 - 1. Distortion
 - 2. Surface blemishes
 - 3. Wear
 - 4. Fractures

WARNING: Replace pins that are distorted, have surface scars, are worn, or contain fractures.

STEP 10

Body Bolt and Body Spacer Sleeve (M-7 in parts diagrams on page 24):

- A. Inspect body bolts and spacer sleeves for wear at position where sleeves contact shackle.
- B. Inspect body bolts.
- C. Make certain body bolt nuts are tight.
- D. Check the body rivet and body to insure that they are tight and there are no gaps where the body halves join together.

When replacing body bolts, tighten bolt and nut, center-punch bolt, and nut at thread joint to lock nut in place. **WARNING: Replace body bolts, nuts, and sleeves if worn or damaged.**

STEP 11

After reassembly, check operation of clamp. All parts should move freely without binding. Refer to exploded view for proper location of component parts. **WARNING: All retaining pins and fasteners must be in place.**

GENERAL

RENFROE products may be returned to the factory for inspection and refurbishment in accordance with an established fee schedule.

Use only RENFROE replacement parts to insure maximum efficiency and safety factor originally built into the product. Refer to CALDWELL Customer Service for instructions on ordering replacement parts.

WARNING: Do not weld, grind, or modify the clamp body or component parts in any manner. In the event the stenciling is worn and not legible or the tag containing the model, capacity, or other pertinent information is missing, do not use clamp until it has been properly labeled.

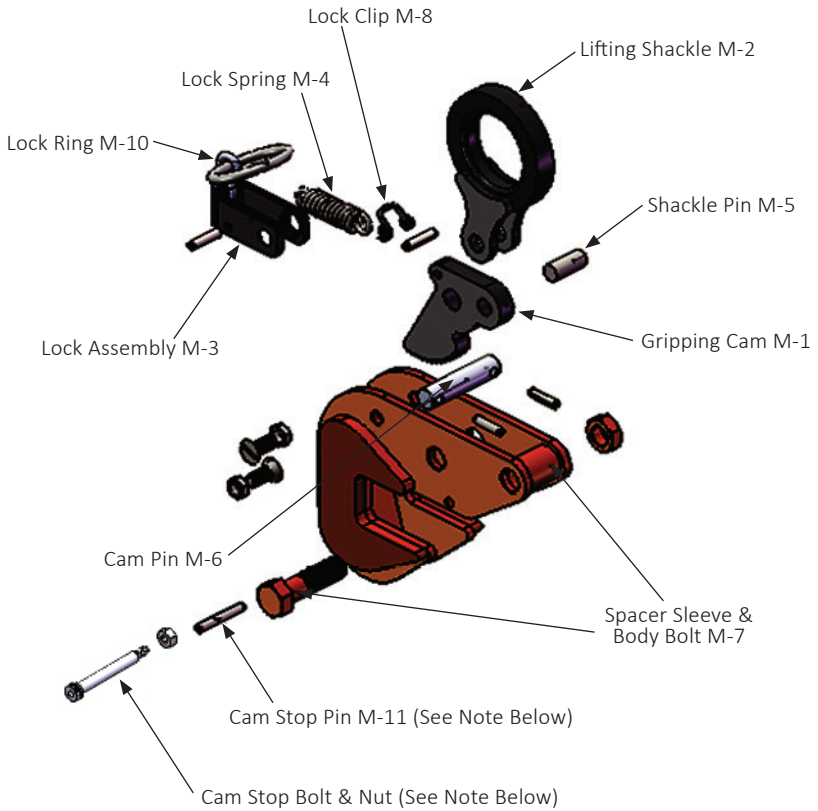

Note:

New clamps use a Cam Stop bolt and nut, which do not need to be replaced unless damaged. Older clamps use a Cam Stop pin. Only the Cam Stop pin is provided in the Model M Repair Kit.

Exclusion of Warranty

There exists no warranties neither expressed nor implied which extend beyond the descriptions or statements contained in the face or any part hereof.

FOR OVER 70 YEARS, J.C. RENFROE HAS PRODUCED THE MOST RELIABLE, DURABLE CLAMPS IN THE INDUSTRY

In an independent test against two other manufacturers with comparable clamps, J.C. RENFROE proved to be the most durable in horizontal and vertical cycle/fatigue testing.

- The test was conducted by Rexnord Innovation Center (RIC), a completely independent accredited laboratory
- Fatigue testing was performed on the three manufacturers' comparable clamps in both vertical and horizontal orientations
- RENFROE'S LPA model completed 10 times more cycles in the horizontal configuration than its nearest competitor
- RENFROE load tests every one of its clamps ensuring that the company maintains its reputation for having the most durable clamps in the market



TESTS RESULTS FROM REXNORD INNOVATION CENTER

Horizontal Fatigue Test

RENFROE	1,664,928 Cycles
Supplier #1	Only 159,672 Cycles
Supplier #2	Only 79,352 Cycles

Vertical Fatigue Test

RENFROE	2,000,000 Cycles
Supplier #1	2,000,000 Cycles
Supplier #2	Only 817,310 Cycles

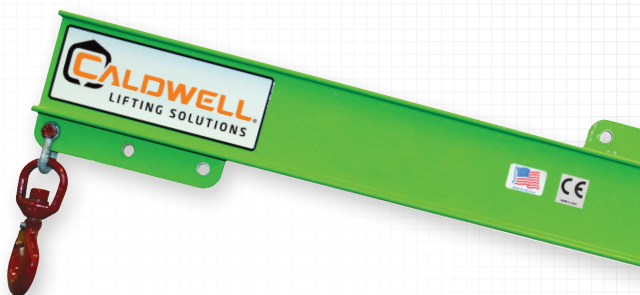

IN STOCK OUT STANDING

BTH LIFTERS READY TO SHIP TODAY

When you need it, you need it right now. Your job is hard enough without having to chase down what should be an easy-to-find Caldwell spreader beam, Renfro plate clamp, or RUD lifting point. With Caldwell backing you up, it really is easy. No chasing required... because more than 400 of our best-selling items are in stock and ready to roll. Every day.

And better yet, they ship for free.



WANT TO KNOW MORE? CALL 800.628.4263 OR ASK YOUR CALDWELL DEALER FOR DETAILS.

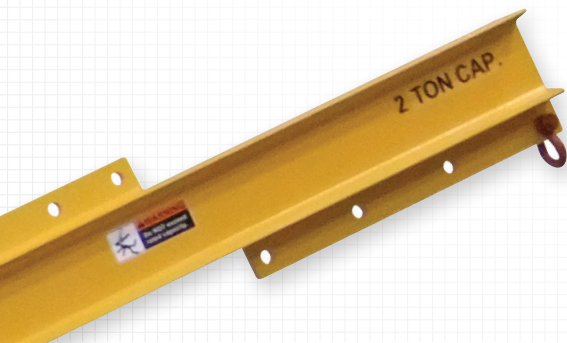



200 State Street, Beloit WI 53511
800.628.4263 | 815.229.5667 | 815.229.5686 (Fax)
caldwellinc.com

IN STOCK

**Ask us about in-stock RENFROE clamps!
Large selection, ready to ship.**