

# DOCK SEAL - D-150-18

APPROX WEIGHT: 133.06 lbs.  
DOES NOT INCLUDE WEIGHT OF POWER OR PACKAGING!!!

\*\*\* ANY ADDITIONS, DELETIONS, OR OMISSIONS MUST BE CORRECTED ON THIS DRAWING AS THIS DRAWING WILL BE CONSIDERED ALL INCLUSIVE \*\*\*  
ALL GRAPHICS PROVIDED ARE FOR REFERENCE ONLY. IF CERTAIN DIMENSIONS ARE CRITICAL PLEASE VERIFY THOSE DIMENSIONS WITH YOUR SALESPERSON

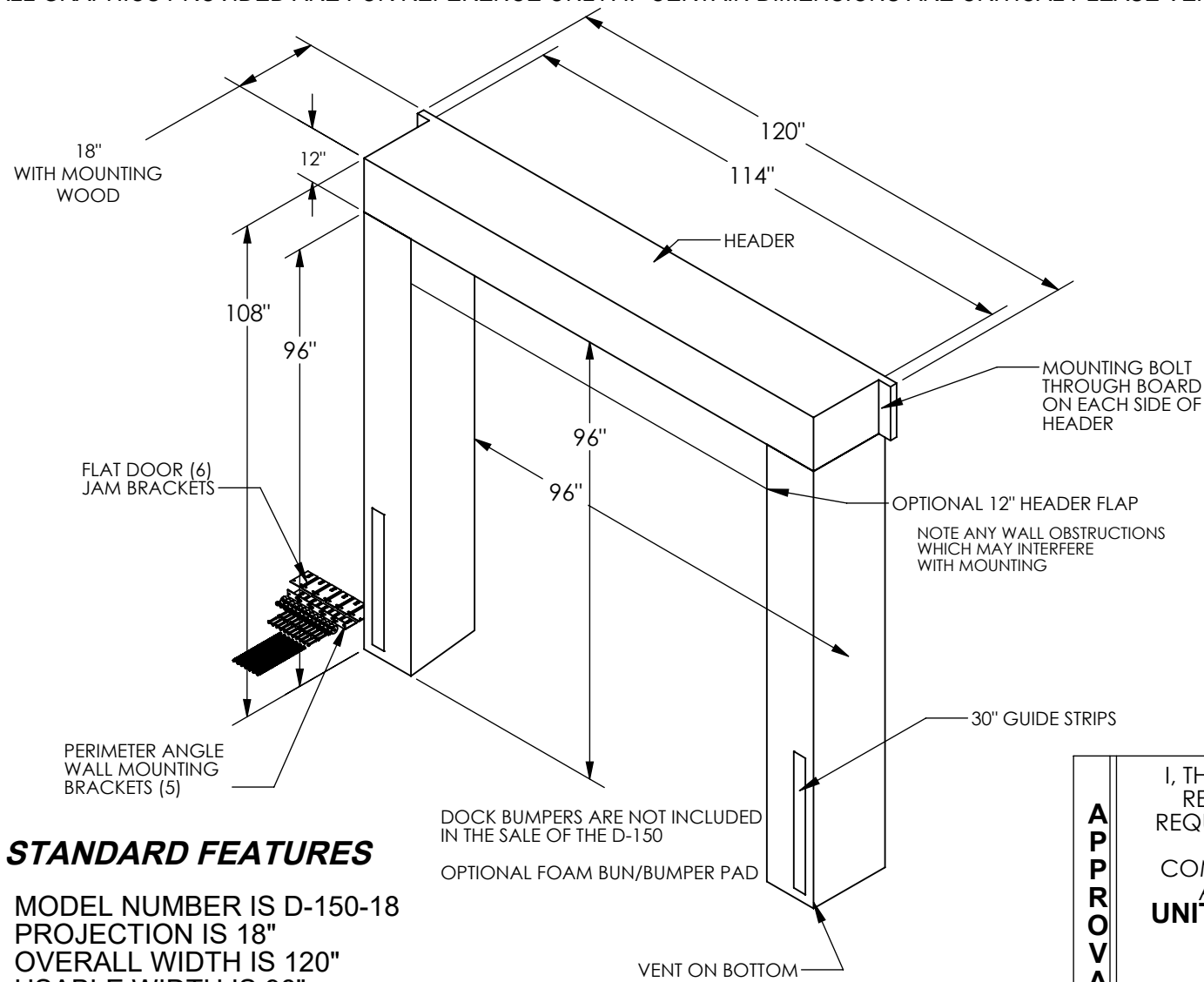

## \*OPTIONS:

- \_\_\_ FULL HEIGHT GUIDE STRIPS, (30" STANDARD)
  - \_\_\_ 18" HIGH HEADER (12 STANDARD)
  - \_\_\_ 12" HEADER FLAT
  - \_\_\_ BOTTOM FOAM BUN / BUMPER PAD
  - \_\_\_ 54 OUNCE FACING
  - \_\_\_ SLOPED VERTICAL SIDES DOR INCLINED OR DECLINED DOCK APPROACH
  - ARMOUR PLEATS
    - \_\_\_ TOP THREE FEET 8" EXPOSURE
    - \_\_\_ FULL HEIGHT 8" EXPOSURE
    - \_\_\_ FULL HEIGHT 4" EXPOSURE (MOST PROTECTION)
- \*AVAILABLE AT ADDITIONAL COSTS

**UNIT IS SPECIAL AND NON RETURNABLE**

DIMENSION TOLERANCE  $\pm 1/4"$

## STANDARD FEATURES

MODEL NUMBER IS D-150-18  
PROJECTION IS 18"  
OVERALL WIDTH IS 120"  
USABLE WIDTH IS 96"  
OVERALL HEIGHT IS 108"  
USEABLE HEIGHT IS 96"

## SPECIAL FEATURES

NONE

\*\* ANY ADDITIONS, DELETIONS, OR OMISSIONS MUST BE CORRECTED ON THIS DRAWING, AS THIS DRAWING WILL BE CONSIDERED ALL INCLUSIVE. \*\*

<b>APPROVAL</b>	I, THE UNDERSIGNED, AGREE THAT THE PRODUCT AS REPRESENTED SATISFIES DESIGN AND DIMENSION REQUIREMENTS. I ALSO ACKNOWLEDGE MY DUTY TO CONFIRM PRODUCT AND INSTALLATION COMPLIANCE WITH ALL APPLICABLE FEDERAL, STATE AND LOCAL REGULATIONS AND STANDARDS.	
	<b>UNITS REQUIRING APPROVAL DRAWINGS OR MODIFIED ARE NON-RETURNABLE</b>	
	<input type="checkbox"/> As drawn	<input type="checkbox"/> As marked
	Signed: _____	Date: _____
	Printed Name: _____	
<b>LEAD TIME WILL START UPON RECEIPT OF SIGNED APPROVAL DRAWING</b>		

DISTRIBUTOR'S NAME:		P.O.#
VESTIL MANUFACTURING		X
DRAWN BY: BCN		DATE: 2/25/2016
REFERENCE: X		SCALE: 1:30
QUOTED LEAD TIME: X		QUOTE # X
		SALES: X
		FILE NAME: 35-007-018