

# HEAVY DUTY POWERED TUGGER - E-TUG-HD-50

APPROX WEIGHT: lbs.  
DOES NOT INCLUDE WEIGHT OF POWER OR PACKAGING!!!

\*\*\*ANY ADDITIONS, DELETIONS, OR OMISSIONS MUST BE CORRECTED ON THIS DRAWING AS THIS DRAWING WILL BE CONSIDERED ALL INCLUSIVE\*\*\*  
ALL GRAPHICS PROVIDED ARE FOR REFERENCE ONLY. IF CERTAIN DIMENSIONS ARE CRITICAL PLEASE VERIFY THOSE DIMENSIONS WITH YOUR SALESPERSON

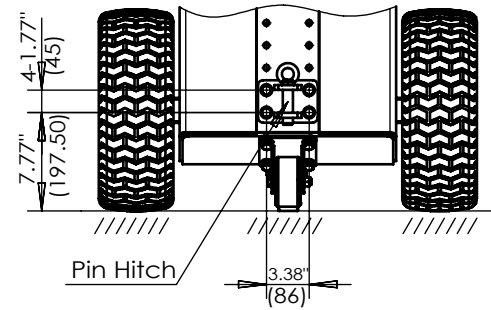
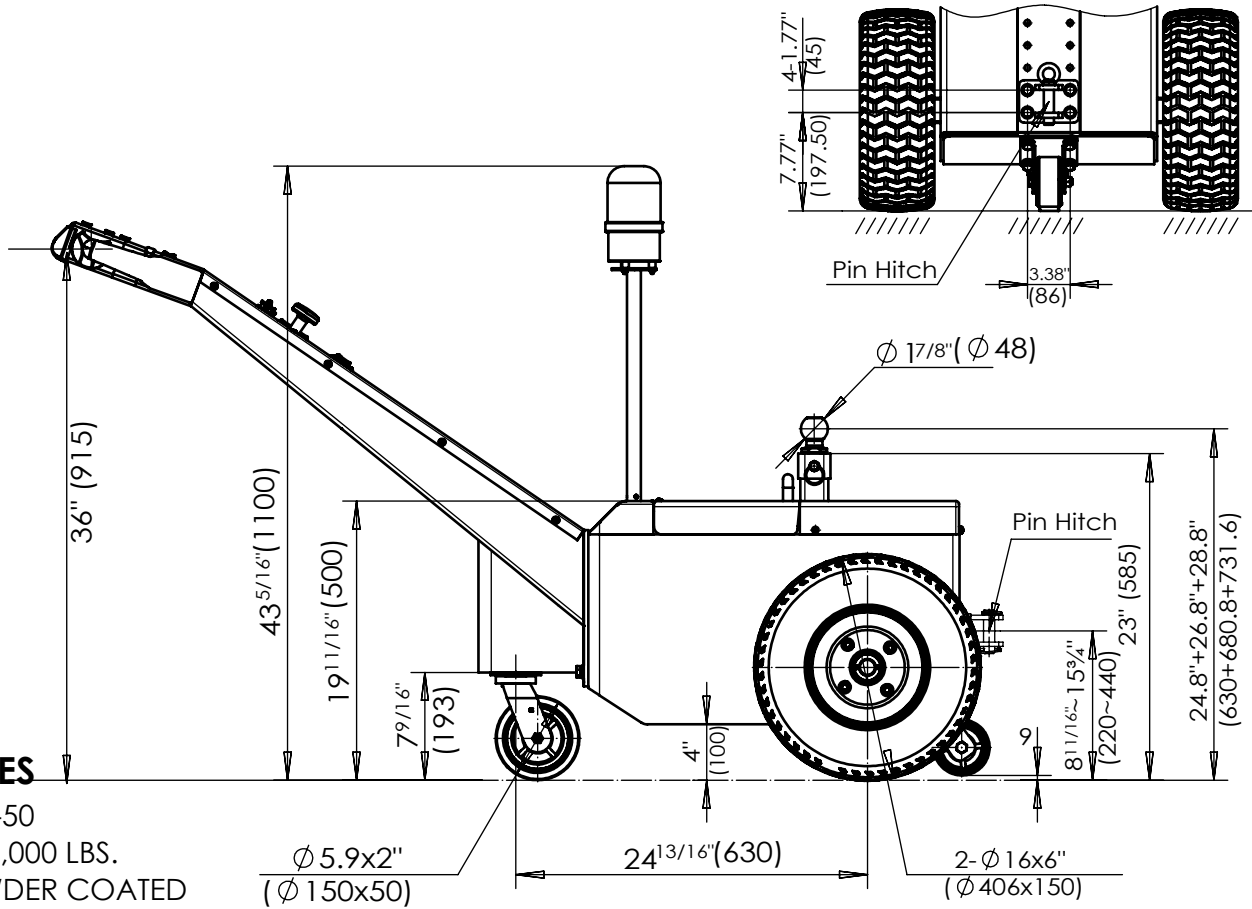

## STANDARD FEATURES

- MODEL NO: E-TUG-HD-50
- UNIFORM CAPACITY: 5,000 LBS.
- TOUGH BAKED IN POWDER COATED BLACK AND YELLOW FINISH
- 24V DC DRIVE MOTOR

## SPECIAL FEATURES

NONE

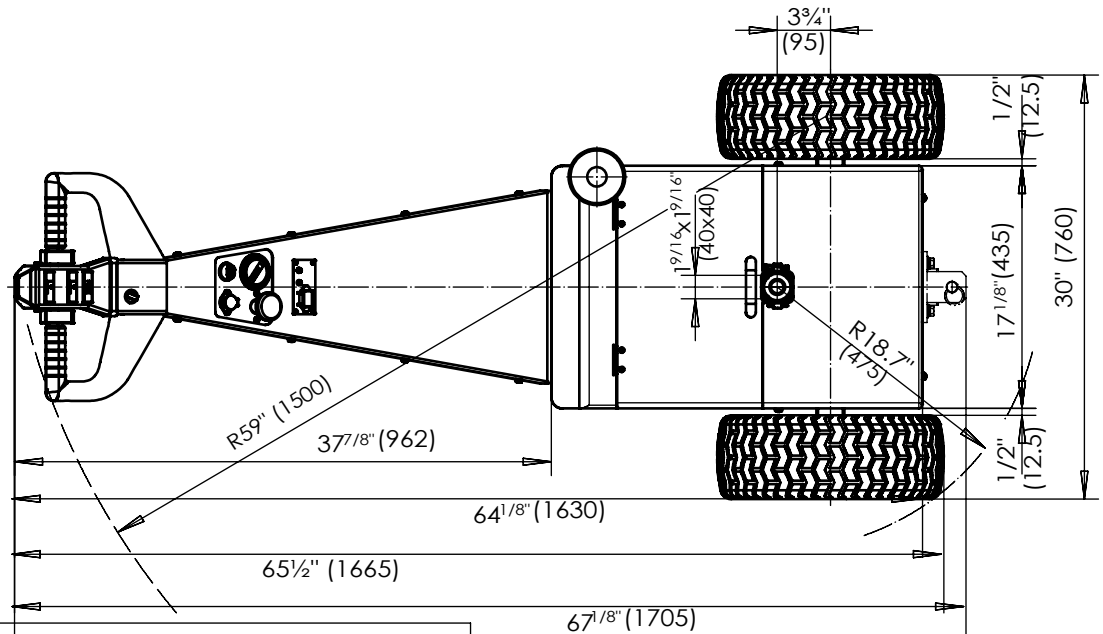

APPROVAL

I, THE UNDERSIGNED, AGREE THAT THE PRODUCT AS REPRESENTED SATISFIES DESIGN AND DIMENSION REQUIREMENTS. I ALSO ACKNOWLEDGE MY DUTY TO CONFIRM PRODUCT AND INSTALLATION COMPLIANCE WITH ALL APPLICABLE FEDERAL, STATE AND LOCAL REGULATIONS AND STANDARDS.  
**UNITS REQUIRING APPROVAL DRAWINGS OR MODIFIED ARE NON-RETURNABLE**

[ ] As drawn [ ] As marked

Signed: \_\_\_\_\_ Date: \_\_\_\_\_

Printed Name: \_\_\_\_\_

LEAD TIME WILL START UPON RECEIPT OF SIGNED APPROVAL DRAWING

DISTRIBUTOR'S NAME:		P.O.#
VESTIL MANUFACTURING		X
DRAWN BY: CRA		W.O.#
DATE: 2/21/2023		X
REFERENCE: X	SCALE: 1:78	SALES: X
QUOTED LEAD TIME: X	QUOTE # X	FILE NAME:
		E-TUG-HD-50