

SKID STEER GRAB BUCKET - EA-SKGB-78

APPROX WEIGHT: 1034 lbs.
DOES NOT INCLUDE WEIGHT OF POWER OR PACKAGING!!!

*** ANY ADDITIONS, DELETIONS, OR OMISSIONS MUST BE CORRECTED ON THIS DRAWING AS THIS DRAWING WILL BE CONSIDERED ALL INCLUSIVE ***

ALL GRAPHICS PROVIDED ARE FOR REFERENCE ONLY. IF CERTAIN DIMENSIONS ARE CRITICAL PLEASE VERIFY THOSE DIMENSIONS WITH YOUR SALESPERSON

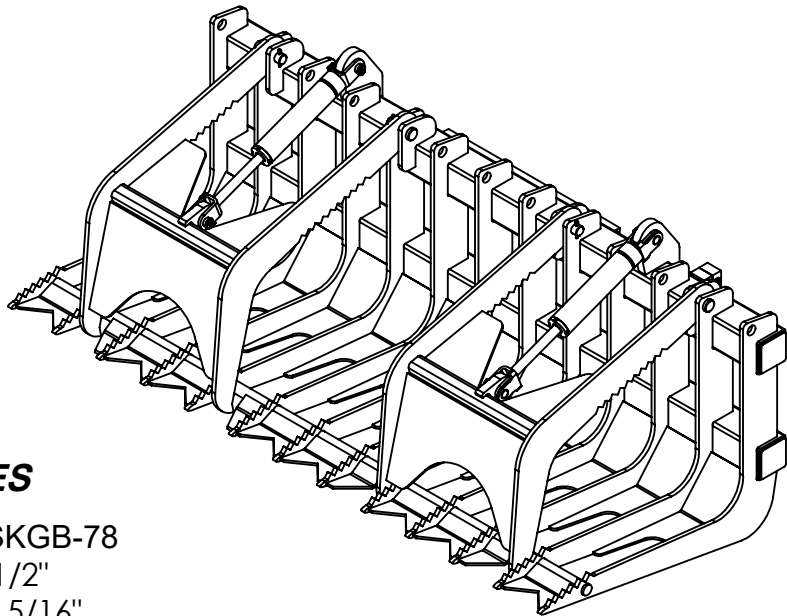
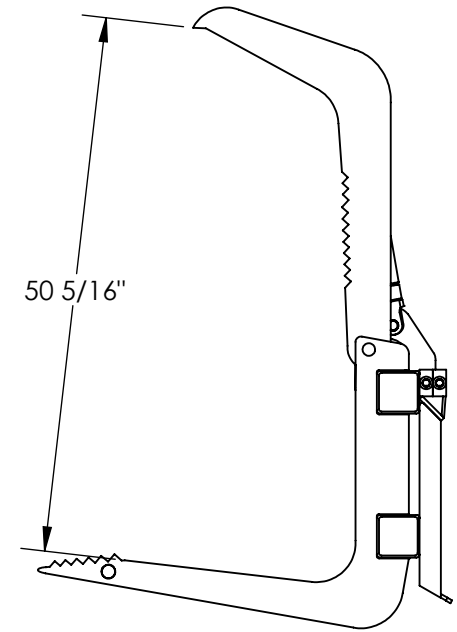
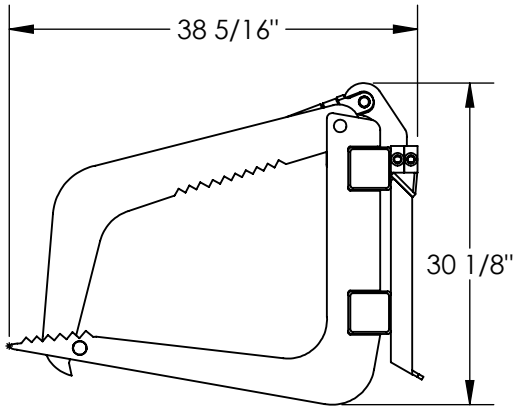
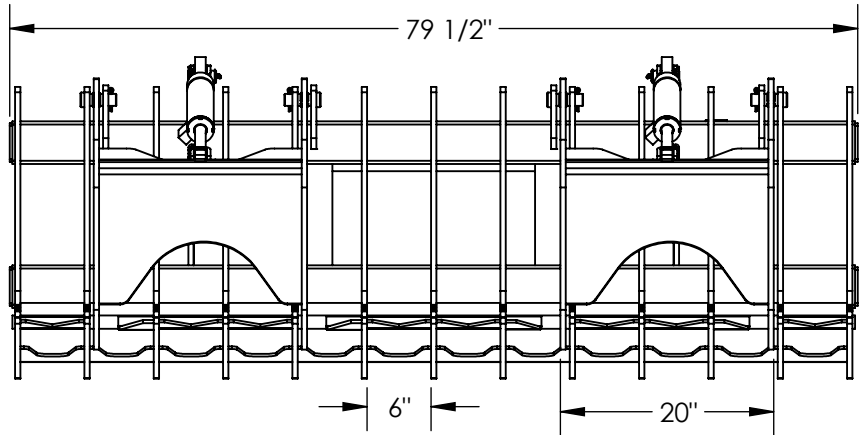

DIMENSION TOLERANCE $\pm 1/4$ "

STANDARD FEATURES

- MODEL NUMBER IS EA-SKGB-78
- OVERALL WIDTH IS 79 1/2"
- OVERALL LENGTH IS 38 5/16"
- OVERALL HEIGHT IS 30 1/8"
- DURABLE LIQUID PAINT BLACK FINISH
- UNIVERSAL MOUNTING PLATE ON 32" CENTER
- CYLINDER MAX OPERATING PRESSURE IS 3000 PSI

SPECIAL FEATURES

NONE

APPROVAL	I, THE UNDERSIGNED, AGREE THAT THE PRODUCT AS REPRESENTED SATISFIES DESIGN AND DIMENSION REQUIREMENTS. I ALSO ACKNOWLEDGE MY DUTY TO CONFIRM PRODUCT AND INSTALLATION COMPLIANCE WITH ALL APPLICABLE FEDERAL, STATE AND LOCAL REGULATIONS AND STANDARDS.	
	UNITS REQUIRING APPROVAL DRAWINGS OR MODIFIED ARE NON-RETURNABLE	
	[] As drawn [] As marked	
	Signed: _____	Date: _____
Printed Name: _____		
<i>LEAD TIME WILL START UPON RECEIPT OF SIGNED APPROVAL DRAWING</i>		

DISTRIBUTOR'S NAME:		P.O.#
VESTIL MANUFACTURING		X
		W.O.#
DRAWN BY: C.CLEMENS		X
DATE: 1/29/21		SALES:
REFERENCE: X		FILE NAME:
SCALE: 1:24		50-007-046
QUOTED LEAD TIME: X	QUOTE #	
	X	