

SKID STEER GRAB BUCKET - EA-SKGB-84

APPROX WEIGHT: 1091 lbs.
DOES NOT INCLUDE WEIGHT OF POWER OR PACKAGING!!!

*** ANY ADDITIONS, DELETIONS, OR OMISSIONS MUST BE CORRECTED ON THIS DRAWING AS THIS DRAWING WILL BE CONSIDERED ALL INCLUSIVE ***

ALL GRAPHICS PROVIDED ARE FOR REFERENCE ONLY. IF CERTAIN DIMENSIONS ARE CRITICAL PLEASE VERIFY THOSE DIMENSIONS WITH YOUR SALESPERSON

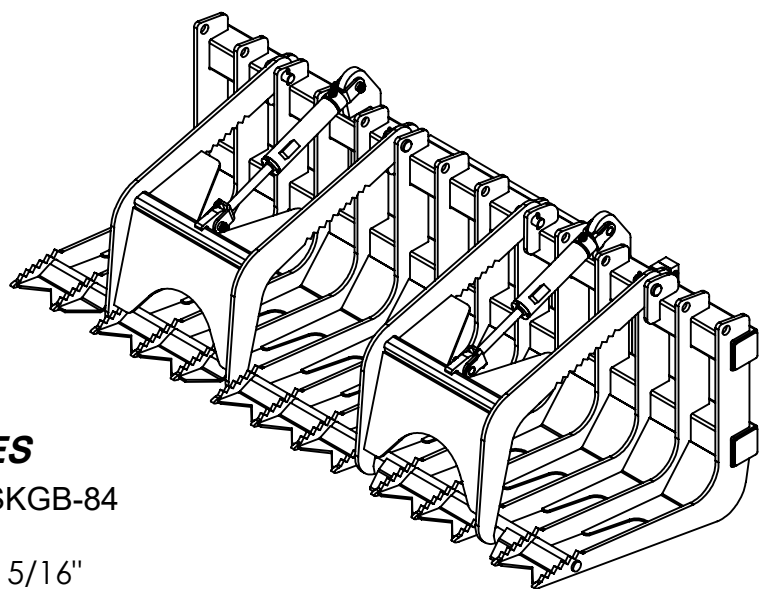
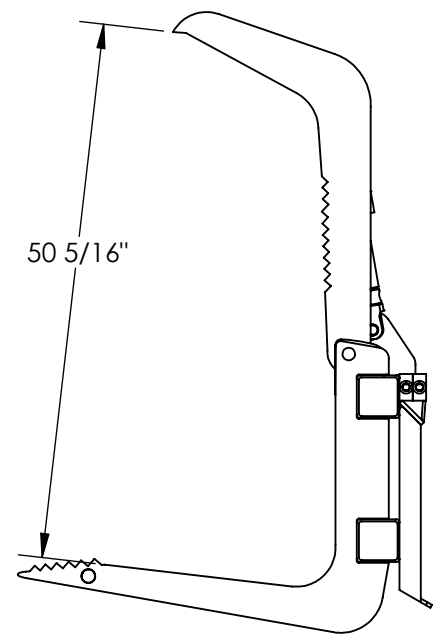
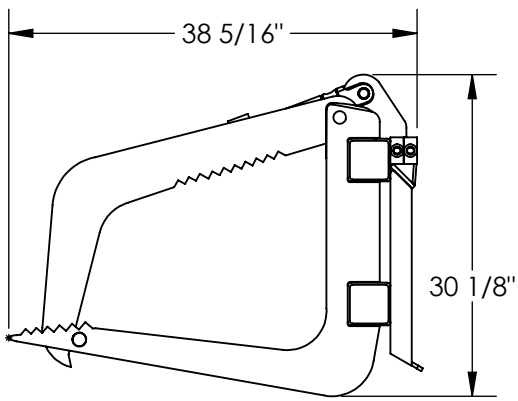
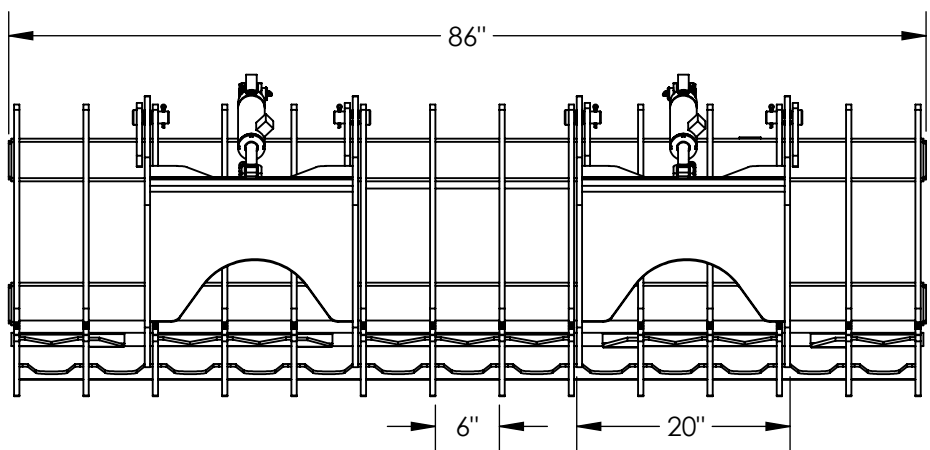

STANDARD FEATURES

- MODEL NUMBER IS EA-SKGB-84
- OVERALL WIDTH IS 86"
- OVERALL LENGTH IS 38 5/16"
- OVERALL HEIGHT IS 30 1/8"
- DURABLE LIQUID PAINT BLACK FINISH
- UNIVERSAL MOUNTING PLATE ON 32" CENTER
- CYLINDER MAX OPERATING PRESSURE IS 3000 PSI

SPECIAL FEATURES

NONE

DIMENSION TOLERANCE ± 1/4"

APPROVAL

I, THE UNDERSIGNED, AGREE THAT THE PRODUCT AS REPRESENTED SATISFIES DESIGN AND DIMENSION REQUIREMENTS. I ALSO ACKNOWLEDGE MY DUTY TO CONFIRM PRODUCT AND INSTALLATION COMPLIANCE WITH ALL APPLICABLE FEDERAL, STATE AND LOCAL REGULATIONS AND STANDARDS.

UNITS REQUIRING APPROVAL DRAWINGS OR MODIFIED ARE NON-RETURNABLE

[] As drawn [] As marked

Signed: _____ Date: _____

Printed Name: _____

LEAD TIME WILL START UPON RECEIPT OF SIGNED APPROVAL DRAWING

| | | |
|----------------------|-------------|---------------|
| DISTRIBUTOR'S NAME: | | P.O.# |
| VESTIL MANUFACTURING | | X |
| DRAWN BY: C.CLEMENS | | DATE: 1/29/21 |
| DATE: 1/29/21 | | SALES: X |
| REFERENCE: X | SCALE: 1:24 | FILE NAME: |
| QUOTED LEAD TIME: X | QUOTE # X | 50-007-047 |