

# SKID STEER LOW PROFILE LEVELING BUCKET - EA-SKSB-72-LP

APPROX WEIGHT: 359.52 lbs.  
DOES NOT INCLUDE WEIGHT OF POWER OR PACKAGING!!!

\*\*\* ANY ADDITIONS, DELETIONS, OR OMISSIONS MUST BE CORRECTED ON THIS DRAWING AS THIS DRAWING WILL BE CONSIDERED ALL INCLUSIVE \*\*\*  
ALL GRAPHICS PROVIDED ARE FOR REFERENCE ONLY. IF CERTAIN DIMENSIONS ARE CRITICAL PLEASE VERIFY THOSE DIMENSIONS WITH YOUR SALESPERSON

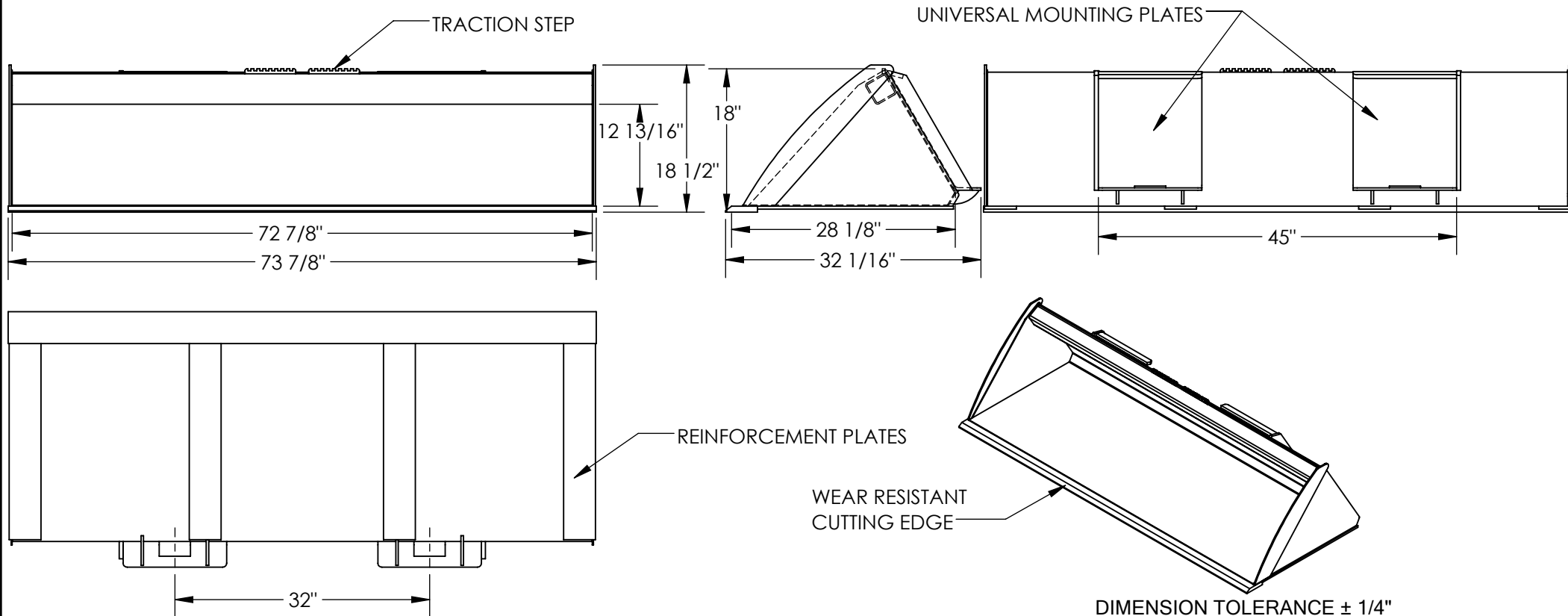

## STANDARD FEATURES

- MODEL NUMBER IS EA-SKSB-72-LP
- OVERALL WIDTH IS 73 7/8"
- USEABLE WIDTH IS 72 7/8"
- OVERALL LENGTH IS 32 1/16"
- USEABLE LENGTH IS 28 1/8"
- OVERALL HEIGHT IS 18 1/2"
- USEABLE HEIGHT IS 12 13/16"
- UNIVERSAL MOUNTING PLATE ON 32" CENTER
- WEAR RESISTANT CUTTING EDGE
- REINFORCEMENT PLATES ON BOTTOM OF BUCKET
- TOUGH BAKED IN POWDER COATED BLACK FINISH

## SPECIAL FEATURES

NONE

APPROVAL

I, THE UNDERSIGNED, AGREE THAT THE PRODUCT AS REPRESENTED SATISFIES DESIGN AND DIMENSION REQUIREMENTS. I ALSO ACKNOWLEDGE MY DUTY TO CONFIRM PRODUCT AND INSTALLATION COMPLIANCE WITH ALL APPLICABLE FEDERAL, STATE AND LOCAL REGULATIONS AND STANDARDS.  
**UNITS REQUIRING APPROVAL DRAWINGS OR MODIFIED ARE NON-RETURNABLE**  
[ ] As drawn [ ] As marked

Signed: \_\_\_\_\_ Date: \_\_\_\_\_

Printed Name: \_\_\_\_\_

LEAD TIME WILL START UPON RECEIPT OF SIGNED APPROVAL DRAWING

|                      |             |            |
|----------------------|-------------|------------|
| DISTRIBUTOR'S NAME:  |             | P.O.#      |
| VESTIL MANUFACTURING |             | X          |
| DRAWN BY: CJC        |             | W.O.#      |
| DATE: 5/18/17        |             | X          |
| REFERENCE: X         | SCALE: 1:18 | SALES: X   |
| QUOTED LEAD TIME: X  | QUOTE #     | FILE NAME: |
|                      | X           | 50-007-006 |