

SKID STEER LOW PROFILE LEVELING BUCKET - EA-SKSB-76-LP

APPROX WEIGHT: 378.10 lbs.
DOES NOT INCLUDE WEIGHT OF POWER OR PACKAGING!!!

*** ANY ADDITIONS, DELETIONS, OR OMISSIONS MUST BE CORRECTED ON THIS DRAWING AS THIS DRAWING WILL BE CONSIDERED ALL INCLUSIVE ***
ALL GRAPHICS PROVIDED ARE FOR REFERENCE ONLY. IF CERTAIN DIMENSIONS ARE CRITICAL PLEASE VERIFY THOSE DIMENSIONS WITH YOUR SALESPERSON

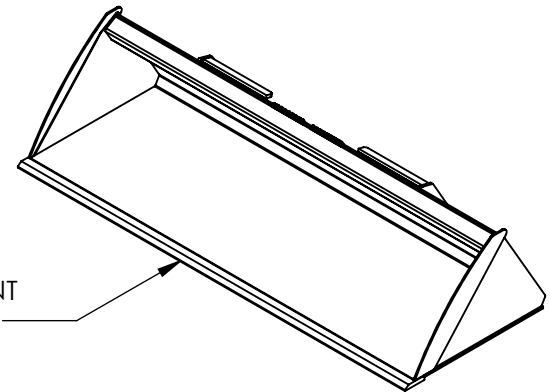
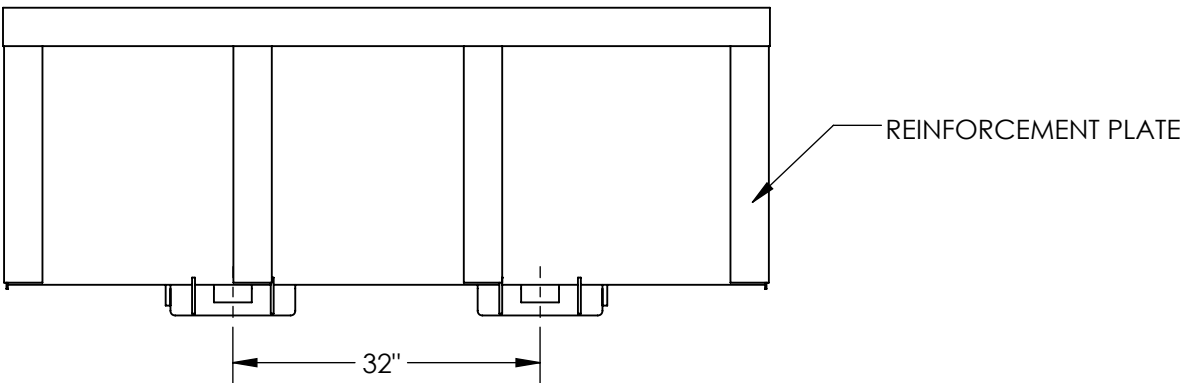
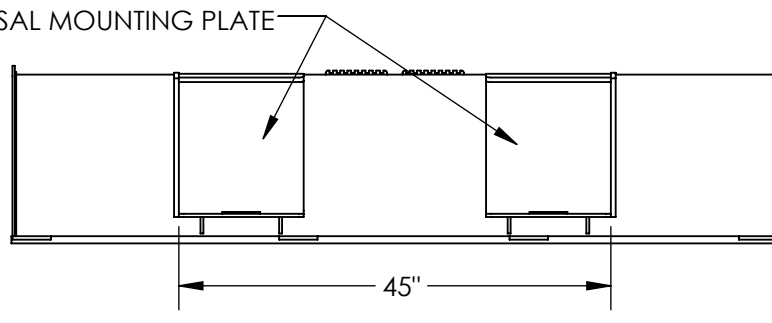
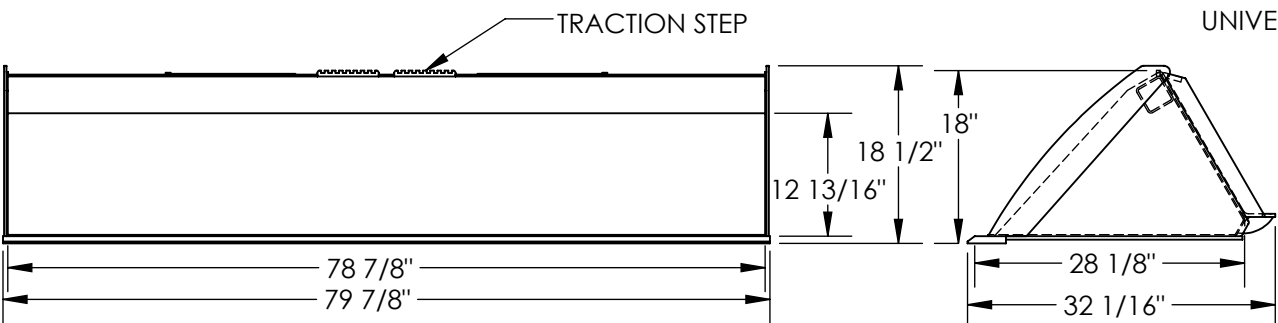

STANDARD FEATURES

- MODEL NUMBER IS EA-SKSB-76-LP
- OVERALL WIDTH IS 79 7/8"
- USEABLE WIDTH IS 78 7/8"
- OVERALL LENGTH IS 32 1/16"
- USEABLE LENGTH IS 28 1/8"
- OVERALL HEIGHT IS 18 1/2"
- USEABLE HEIGHT IS 12 13/16"
- UNIVERSAL MOUNTING PLATE

SPECIAL FEATURES

NONE

- ON 32" CENTER
- WEAR RESISTANT CUTTING EDGE
- REINFORCEMENT PLATES ON BOTTOM OF BUCKET
- TOUGH BAKED IN POWDER COATED BLACK FINISH

A P P R O V A L

I, THE UNDERSIGNED, AGREE THAT THE PRODUCT AS REPRESENTED SATISFIES DESIGN AND DIMENSION REQUIREMENTS. I ALSO ACKNOWLEDGE MY DUTY TO CONFIRM PRODUCT AND INSTALLATION COMPLIANCE WITH ALL APPLICABLE FEDERAL, STATE AND LOCAL REGULATIONS AND STANDARDS.

UNITS REQUIRING APPROVAL DRAWINGS OR MODIFIED ARE NON-RETURNABLE

As drawn As marked

Signed: _____ Date: _____

Printed Name: _____

LEAD TIME WILL START UPON RECEIPT OF SIGNED APPROVAL DRAWING

DISTRIBUTOR'S NAME:		P.O.#
VESTIL MANUFACTURING		X
DRAWN BY: CJC	DATE: 5/18/17	W.O.#
REFERENCE: X	SCALE: 1:20	X
QUOTED LEAD TIME: X	QUOTE #	SALES: X
	X	FILE NAME:
		50-007-007