

ALUMINUM TRUCK DOCKPLATE - EH-4836

APPROX WEIGHT: 98.80 lbs.
 DOES NOT INCLUDE WEIGHT OF POWER OR PACKAGING!!!

*** ANY ADDITIONS, DELETIONS, OR OMISSIONS MUST BE CORRECTED ON THIS DRAWING AS THIS DRAWING WILL BE CONSIDERED ALL INCLUSIVE ***

ALL GRAPHICS PROVIDED ARE FOR REFERENCE ONLY. IF CERTAIN DIMENSIONS ARE CRITICAL PLEASE VERIFY THOSE DIMENSIONS WITH YOUR SALESPERSON

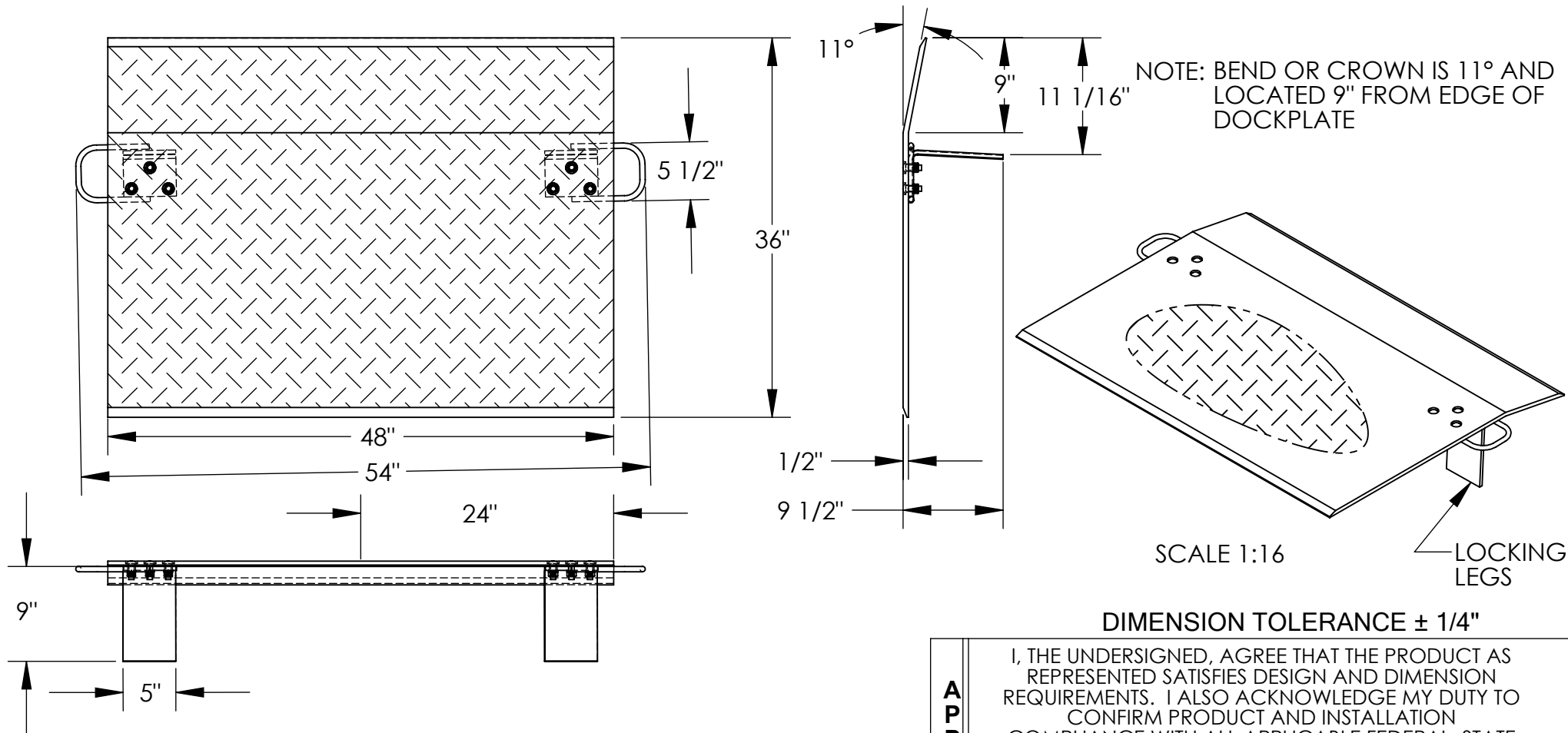

STANDARD FEATURES

- MODEL NUMBER IS EH-4836
- CAPACITY IS 5,300 LBS.
- OVERALL WIDTH IS 54"
- DECK WIDTH IS 48"
- OVERALL LENGTH IS 36"
- OVERALL HEIGHT IS 9 1/2"
- THICKNESS IS 1/2"
- HANDLES ARE 5 1/2" x 24"
- LOCKING LEGS ARE 5" x 9"

SPECIAL FEATURES

NONE

APPROVAL

I, THE UNDERSIGNED, AGREE THAT THE PRODUCT AS REPRESENTED SATISFIES DESIGN AND DIMENSION REQUIREMENTS. I ALSO ACKNOWLEDGE MY DUTY TO CONFIRM PRODUCT AND INSTALLATION COMPLIANCE WITH ALL APPLICABLE FEDERAL, STATE AND LOCAL REGULATIONS AND STANDARDS.

UNITS REQUIRING APPROVAL DRAWINGS OR MODIFIED ARE NON-RETURNABLE

[] As drawn [] As marked

Signed: _____ Date: _____

Printed Name: _____

LEAD TIME WILL START UPON RECEIPT OF SIGNED APPROVAL DRAWING

DISTRIBUTOR'S NAME:		P.O.#
VESTIL MANUFACTURING		X
DRAWN BY: ADL	DATE: 1/19/06	W.O.#
REFERENCE: X	SCALE: 1:14	X
QUOTED LEAD TIME: X	QUOTE #	SALES: X
	X	FILE NAME:
		12-007-028