

# ALUMINUM TRUCK DOCKPLATE - EH-4860

APPROX WEIGHT: 158.18 lbs.  
 DOES NOT INCLUDE WEIGHT OF POWER OR PACKAGING!!!

\*\*\* ANY ADDITIONS, DELETIONS, OR OMISSIONS MUST BE CORRECTED ON THIS DRAWING AS THIS DRAWING WILL BE CONSIDERED ALL INCLUSIVE \*\*\*

ALL GRAPHICS PROVIDED ARE FOR REFERENCE ONLY. IF CERTAIN DIMENSIONS ARE CRITICAL PLEASE VERIFY THOSE DIMENSIONS WITH YOUR SALESPERSON

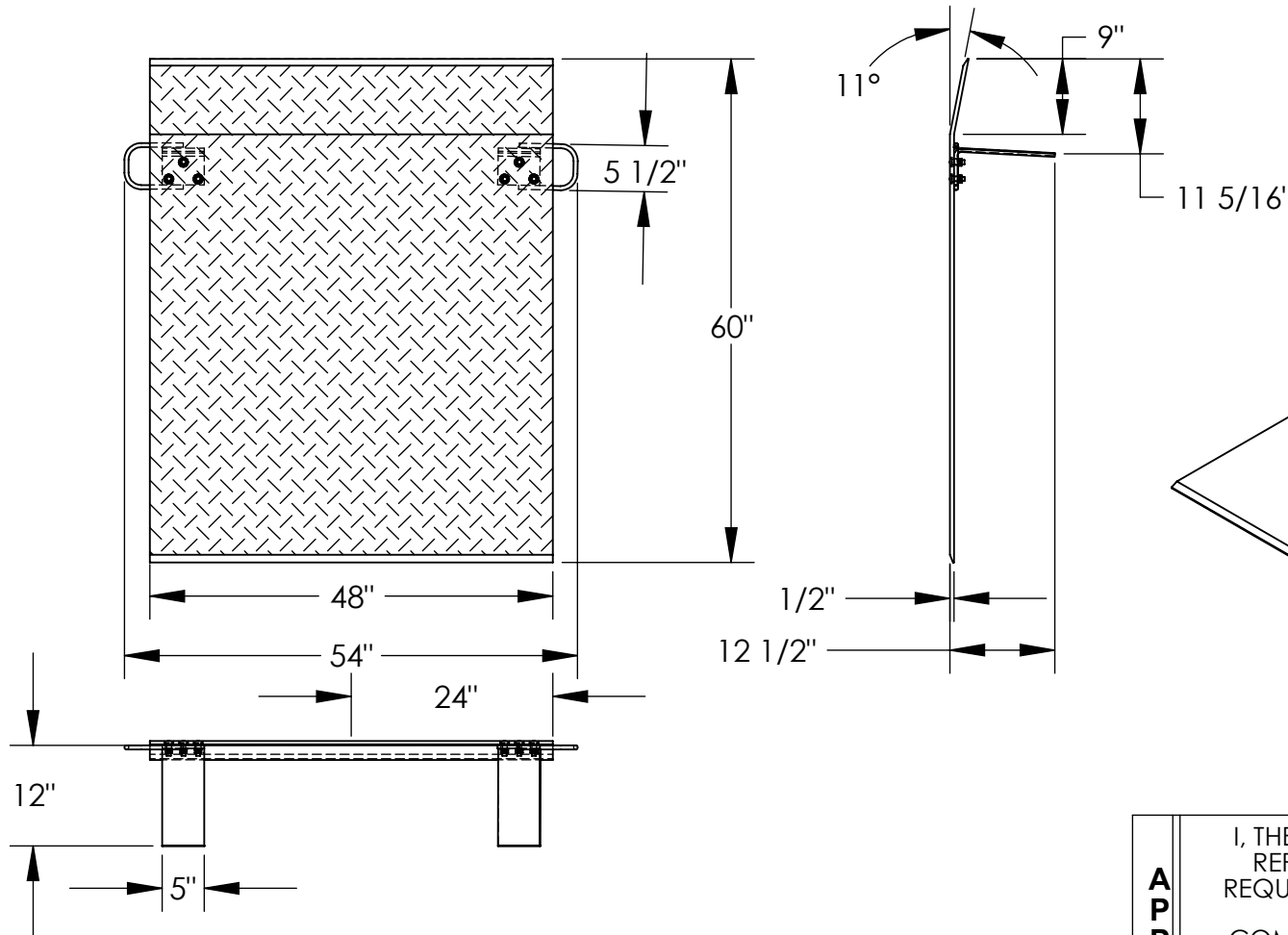

NOTE: BEND OR CROWN IS 11° AND LOCATED 9" FROM EDGE OF DOCKPLATE

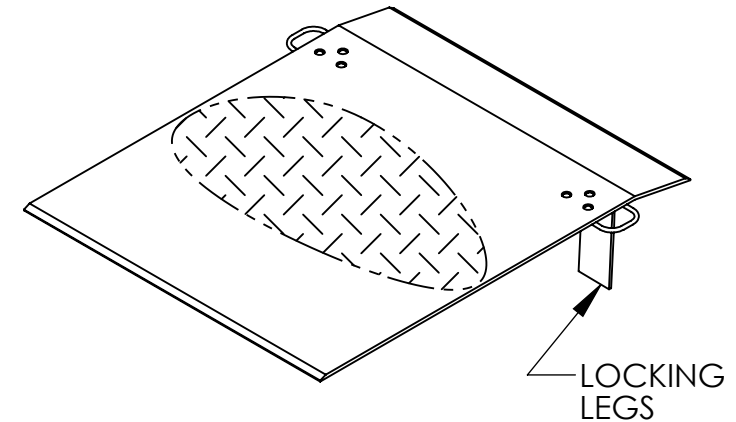

SCALE 1:22

DIMENSION TOLERANCE ± 1/4"

## STANDARD FEATURES

- MODEL NUMBER IS EH-4860
- CAPACITY IS 2,900 LBS.
- OVERALL WIDTH IS 54"
- DECK WIDTH IS 48"
- OVERALL LENGTH IS 60"
- OVERALL HEIGHT IS 12 1/2"
- THICKNESS IS 1/2"
- HANDLES ARE 5 1/2" x 24"
- LOCKING LEGS ARE 5" x 12"

## SPECIAL FEATURES

NONE

APPROVAL

I, THE UNDERSIGNED, AGREE THAT THE PRODUCT AS REPRESENTED SATISFIES DESIGN AND DIMENSION REQUIREMENTS. I ALSO ACKNOWLEDGE MY DUTY TO CONFIRM PRODUCT AND INSTALLATION COMPLIANCE WITH ALL APPLICABLE FEDERAL, STATE AND LOCAL REGULATIONS AND STANDARDS.  
**UNITS REQUIRING APPROVAL DRAWINGS OR MODIFIED ARE NON-RETURNABLE**  
 As drawn       As marked

Signed: \_\_\_\_\_ Date: \_\_\_\_\_

Printed Name: \_\_\_\_\_

LEAD TIME WILL START UPON RECEIPT OF SIGNED APPROVAL DRAWING

DISTRIBUTOR'S NAME:		P.O.#
VESTIL MANUFACTURING		X
DRAWN BY: ADL		W.O.#
DATE: 1/19/06		X
REFERENCE: X	SCALE: 1:22	SALES: X
QUOTED LEAD TIME: X	QUOTE #	FILE NAME:
	X	12-007-036