

ELECTRIC HYDRAULIC SCISSOR LIFT TABLE - EHLT-4896-2-55

APPROX WEIGHT: 1095 lbs.
 DOES NOT INCLUDE WEIGHT OF POWER OR PACKAGING!!!

*** ANY ADDITIONS, DELETIONS, OR OMISSIONS MUST BE CORRECTED ON THIS DRAWING AS THIS DRAWING WILL BE CONSIDERED ALL INCLUSIVE ***
 ALL GRAPHICS PROVIDED ARE FOR REFERENCE ONLY. IF CERTAIN DIMENSIONS ARE CRITICAL PLEASE VERIFY THOSE DIMENSIONS WITH YOUR SALESPERSON

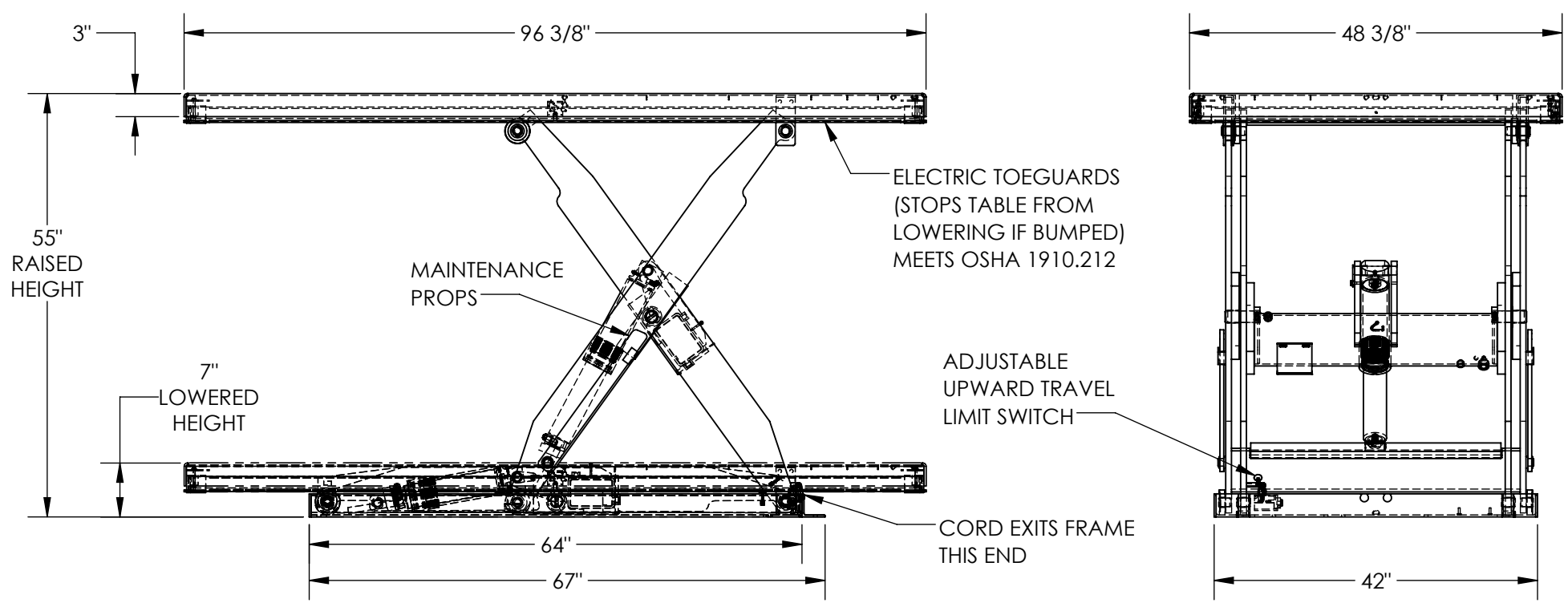

STANDARD FEATURES

- MODEL NUMBER IS EHLT-4896-2-55
- PLATFORM LENGTH IS 96 3/8"
- PLATFORM WIDTH IS 48 3/8"
- PLATFORM RAISED MAX HEIGHT IS 55"
- PLATFORM LOWERED MIN HEIGHT IS 7"
- OVERALL LENGTH IS 96 3/8"
- USABLE LENGTH IS 96 3/8"
- OVERALL WIDTH IS 48 3/8"
- USABLE WIDTH IS 48 3/8"
- TABLE CAPACITY (EVENLY DISTRIBUTED)
 LOAD IS 2,000 LBS
- INTERNAL POWER UNIT
 2 HP MOTOR (@ 3 PHASE)
 3/4 HP MOTOR (@ 1 PHASE)
- CONTROL IS HANDHELD, 2 BUTTON, NEMA 4
 PENDANT WITH MINIMUM 8' USABLE COIL CORD
- SAFETY MAINTENANCE PROPS
- DISPLACEMENT STYLE CYLINDER
 INSTALLED ROD DOWN
- EMERGENCY SAFETY STOP HYDRAULIC FUSE
 IN EACH CYLINDER
- UPPER TRAVEL LIMIT SWITCH
- ELECTRIC PINCH POINT GUARD
- UNITS HAVE 2' TEST LEAD AND PIG TAIL
- DURABLE LIQUID PAINT BLUE FINISH

PLEASE CIRCLE SPECIFICATIONS:

POWER	<input checked="" type="checkbox"/> AC	<input type="checkbox"/> DC (12V)	<input type="checkbox"/> AIR/OIL
MOTOR VOLTAGE	<input type="checkbox"/> 115	<input type="checkbox"/> 208	<input checked="" type="checkbox"/> 230
DEDICATED CIRCUIT REQUIRED 60Hz			
MOTOR PHASE	<input type="checkbox"/> SINGLE	<input checked="" type="checkbox"/> THREE	
CONTROL	<input checked="" type="checkbox"/> HAND	<input type="checkbox"/> FOOT	

SPECIAL FEATURES

NONE

DIMENSION TOLERANCE ± 1/4"

I, THE UNDERSIGNED, AGREE THAT THE PRODUCT AS REPRESENTED SATISFIES DESIGN AND DIMENSION REQUIREMENTS. I ALSO ACKNOWLEDGE MY DUTY TO CONFIRM PRODUCT AND INSTALLATION COMPLIANCE WITH ALL APPLICABLE FEDERAL, STATE AND LOCAL REGULATIONS AND STANDARDS.

UNITS REQUIRING APPROVAL DRAWINGS OR MODIFIED ARE NON-RETURNABLE

[] As drawn [] As marked

Signed: _____ Date: _____

Printed Name: _____

LEAD TIME WILL START UPON RECEIPT OF SIGNED APPROVAL DRAWING

DISTRIBUTOR'S NAME:		P.O.#
VESTIL MANUFACTURING		X
DRAWN BY: CMP		W.O.#
DATE: 05/25/2023		X
REFERENCE: X	SCALE: 1:20	SALES: X
QUOTED LEAD TIME: XX WEEKS	QUOTE # X	FILE NAME:
		24-007-201-002