

TANDEM ELECTRIC HYDRAULIC SCISSOR LIFT TABLE - EHLT-TL-30144-4-46

APPROX WEIGHT: 1776.0965 lbs.
 DOES NOT INCLUDE WEIGHT OF POWER OR PACKAGING!!!

*** ANY ADDITIONS, DELETIONS, OR OMISSIONS MUST BE CORRECTED ON THIS DRAWING AS THIS DRAWING WILL BE CONSIDERED ALL INCLUSIVE ***

ALL GRAPHICS PROVIDED ARE FOR REFERENCE ONLY. IF CERTAIN DIMENSIONS ARE CRITICAL PLEASE VERIFY THOSE DIMENSIONS WITH YOUR SALESPERSON

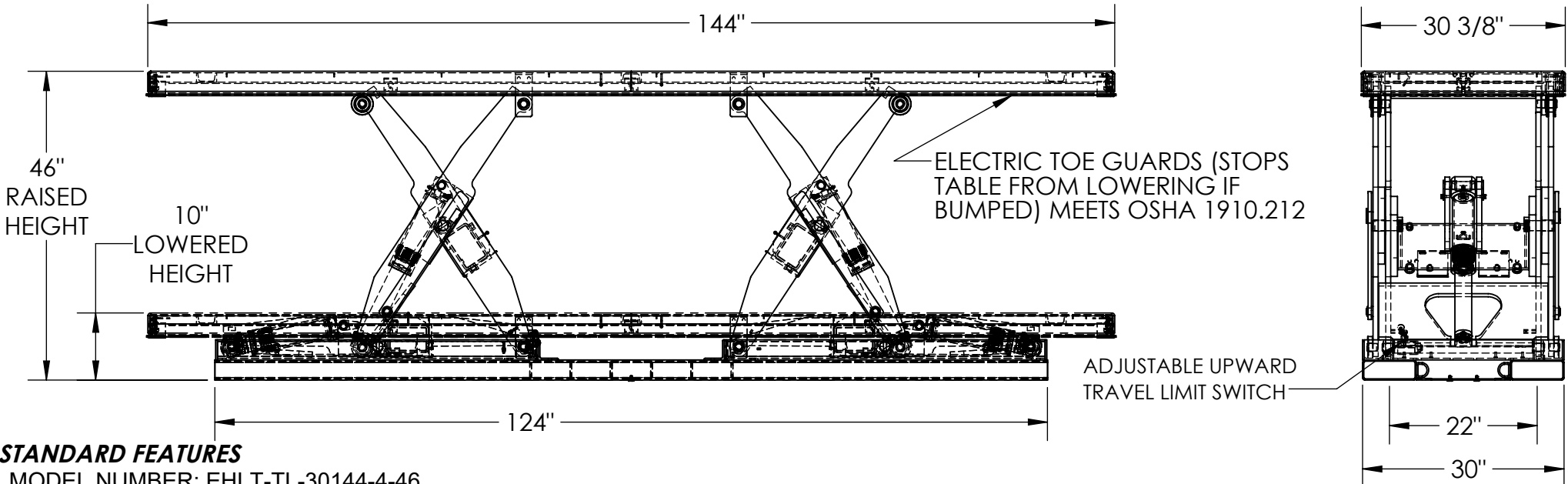

STANDARD FEATURES

- MODEL NUMBER: EHLT-TL-30144-4-46
- PLATFORM WIDTH: 30 3/8"
- PLATFORM LENGTH: 144"
- PLATFORM RAISED HEIGHT: 46"
- PLATFORM LOWERED HEIGHT: 10"
- TABLE CAPACITY (EVENLY DISTRIBUTED) LOAD: 2,000 LBS.
- INTERNAL POWER UNIT
- CONTROL IS HANDHELD, 2 BUTTON, NEMA 4
- PENDANT WITH MINIMUM 8' USABLE COIL CORD
- SAFETY MAINTENANCE PROPS, DISPLACEMENT STYLE CYLINDERS INSTALLED ROD DOWN
- EMERGENCY SAFETY STOP HYDRAULIC FUSES IN ALL CYLINDERS
- UNITS HAVE 2' TEST LEAD AND PIG TAIL
- 460V AC, REMOTE 3 PHASE POWER UNIT
- DURABLE LIQUID PAINT BLUE FINISH

SPECIAL FEATURES

NONE

PLEASE CIRCLE SPECIFICATIONS:

POWER	<input checked="" type="checkbox"/> AC	<input type="checkbox"/> DC (12V)	<input type="checkbox"/> AIR/OIL
MOTOR VOLTAGE	<input type="checkbox"/> 115	<input type="checkbox"/> 208	<input checked="" type="checkbox"/> 460
DEDICATED CIRCUIT REQUIRED 60Hz			
MOTOR PHASE	<input type="checkbox"/> SINGLE	<input checked="" type="checkbox"/> THREE	
CONTROL	<input checked="" type="checkbox"/> HAND	<input type="checkbox"/> FOOT	

DIMENSION TOLERANCE ± 1/4"

APPROVAL

I, THE UNDERSIGNED, AGREE THAT THE PRODUCT AS REPRESENTED SATISFIES DESIGN AND DIMENSION REQUIREMENTS. I ALSO ACKNOWLEDGE MY DUTY TO CONFIRM PRODUCT AND INSTALLATION COMPLIANCE WITH ALL APPLICABLE FEDERAL, STATE AND LOCAL REGULATIONS AND STANDARDS.

UNITS REQUIRING APPROVAL DRAWINGS OR MODIFIED ARE NON-RETURNABLE

[] As drawn [] As marked

Signed: _____ Date: _____

Printed Name: _____

LEAD TIME WILL START UPON RECEIPT OF SIGNED APPROVAL DRAWING

DISTRIBUTOR'S NAME:		P.O.#
VESTIL MANUFACTURING		X
DRAWN BY: CRA	DATE: 09/07/2022	W.O.#
REFERENCE: X	SCALE: 1:22	X
QUOTED LEAD TIME: X	QUOTE #	SALES: X
	X	FILE NAME:
		24-007-984