

HYDRAULIC SCISSOR LIFT CART - EHLT-WS-3248-1.5-36

APPROX WEIGHT: 302.29 lbs.
 DOES NOT INCLUDE WEIGHT OF POWER OR PACKAGING!!!

*** ANY ADDITIONS, DELETIONS, OR OMISSIONS MUST BE CORRECTED ON THIS DRAWING AS THIS DRAWING WILL BE CONSIDERED ALL INCLUSIVE ***

ALL GRAPHICS PROVIDED ARE FOR REFERENCE ONLY. IF CERTAIN DIMENSIONS ARE CRITICAL PLEASE VERIFY THOSE DIMENSIONS WITH YOUR SALESPERSON

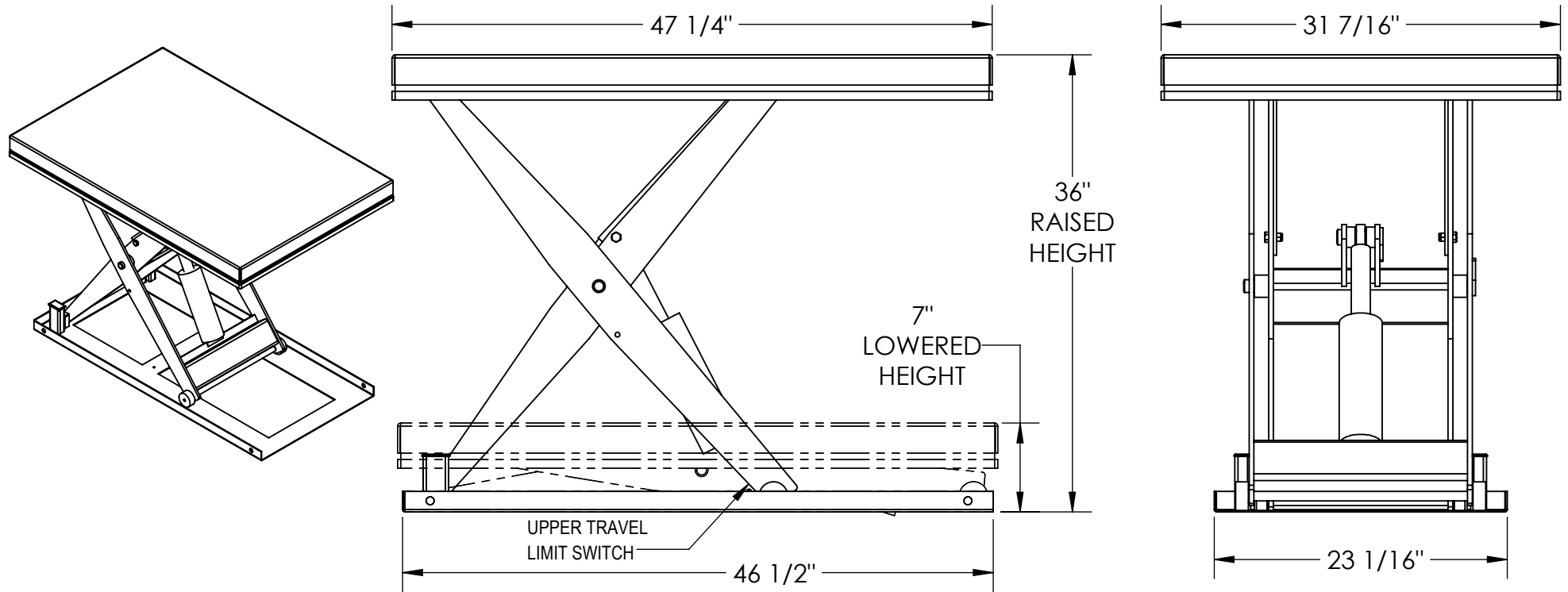

STANDARD FEATURES

- MODEL NUMBER IS EHLT-WS-3248-1.5-36
- OVERALL WIDTH IS 31 7/16"
- OVERALL LENGTH IS 47 1/4"
- RAISED HEIGHT IS 36"
- LOWERED HEIGHT IS 7"
- TABLE CAPACITY (EVENLY DISTRIBUTED) IS 1,500 LBS.
- CONTROL IS HANDHELD 2 BUTTON, NEMA 4 PENDANT
- SAFETY MAINTENANCE PROPS, DISPLACEMENT
- STYLE CYLINDERS INSTALLED ROD DOWN
- EMERGENCY SAFETY STOP HYDRAULIC FUSES
- UPPER TRAVEL LIMIT SWITCH
- ELECTRIC PINCH POINT GUARD
- DURABLE LIQUID PAINT YELLOW FINISH

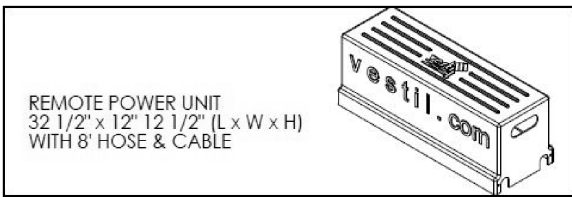

APPROVAL

I, THE UNDERSIGNED, AGREE THAT THE PRODUCT AS REPRESENTED SATISFIES DESIGN AND DIMENSION REQUIREMENTS. I ALSO ACKNOWLEDGE MY DUTY TO CONFIRM PRODUCT AND INSTALLATION COMPLIANCE WITH ALL APPLICABLE FEDERAL, STATE AND LOCAL REGULATIONS AND STANDARDS.
UNITS REQUIRING APPROVAL DRAWINGS OR MODIFIED ARE NON-RETURNABLE

[] As drawn [] As marked
 Signed: _____ Date: _____

Printed Name: _____
 LEAD TIME WILL START UPON RECEIPT OF SIGNED APPROVAL DRAWING

SPECIAL FEATURES

NONE

POWER	<input checked="" type="checkbox"/> AC	<input type="checkbox"/> DC (12V)	<input type="checkbox"/> AIR/OIL
MOTOR VOLTAGE	<input checked="" type="checkbox"/> 115	<input type="checkbox"/> 208	<input type="checkbox"/> 230 460
DEDICATED CIRCUIT REQUIRED 60Hz			
MOTOR PHASE	<input type="checkbox"/> SINGLE	<input type="checkbox"/> THREE	
CONTROL	<input checked="" type="checkbox"/> HAND	<input type="checkbox"/> FOOT	

DISTRIBUTOR'S NAME: _____

VESTIL MANUFACTURING

DRAWN BY: CRA DATE: 9/6/2023

REFERENCE: X SCALE: 1:12

QUOTED LEAD TIME: X QUOTE # X

P.O.# X
 W.O.# X
 SALES: X
 FILE NAME: 01-007-528-001