

GROUND LIFT SCISSOR TABLE - EHLTG-4470-4-48

APPROX WEIGHT: 1940.76 lbs.
 DOES NOT INCLUDE WEIGHT OF POWER OR PACKAGING!!!

*** ANY ADDITIONS, DELETIONS, OR OMISSIONS MUST BE CORRECTED ON THIS DRAWING AS THIS DRAWING WILL BE CONSIDERED ALL INCLUSIVE ***

ALL GRAPHICS PROVIDED ARE FOR REFERENCE ONLY. IF CERTAIN DIMENSIONS ARE CRITICAL PLEASE VERIFY THOSE DIMENSIONS WITH YOUR SALESPERSON

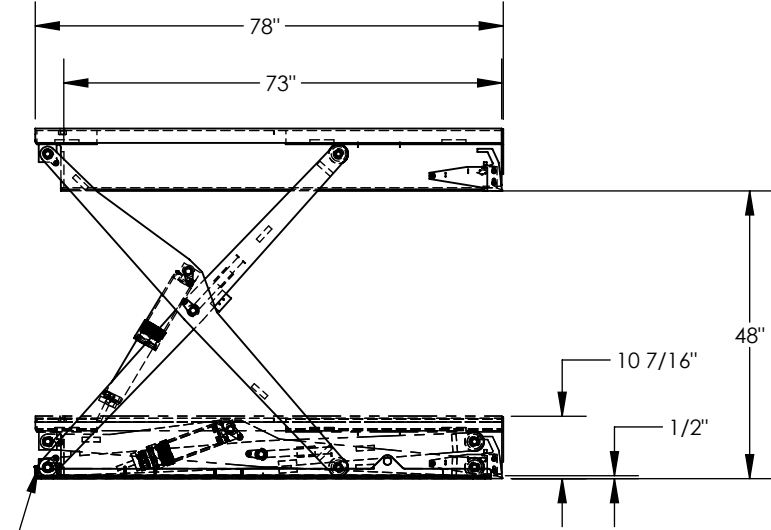

HOSE & CORD EXIT FRAME THIS END

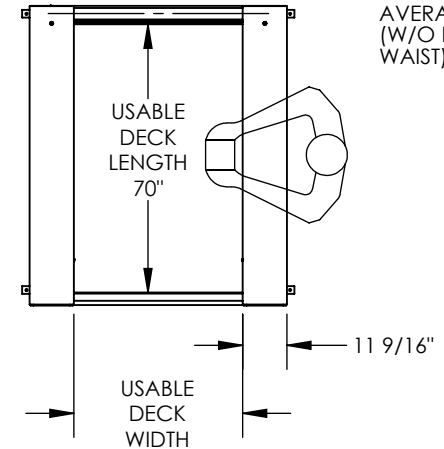
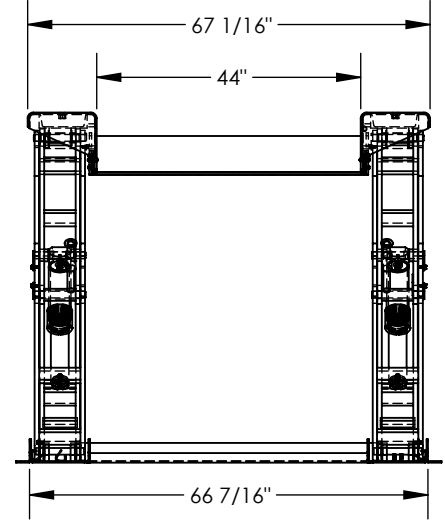

AVERAGE REACH (W/O BENDING AT WAIST)

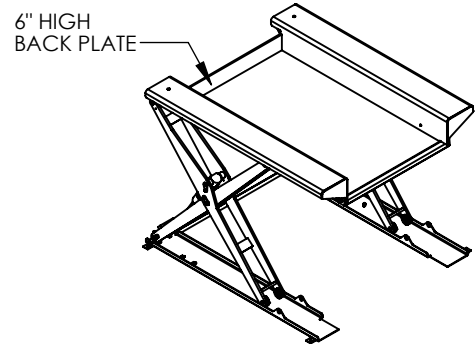

6" HIGH BACK PLATE

REMOTE POWER UNIT:
 32 1/2" x 12" x 12 1/2" (L x W x H)
 WITH 8' HOSE & CABLE

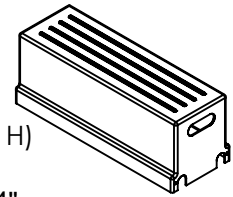

DIMENSION TOLERANCE ± 1/4"

STANDARD FEATURES

- MODEL NUMBER IS: EHLTG-4470-4-48
- PLATFORM WIDTH (USABLE): 44"
- PLATFORM LENGTH (USABLE): 70"
- OVERALL WIDTH: 67 1/16"
- OVERALL LENGTH: 78"
- PLATFORM RAISED HEIGHT: 48"
- PLATFORM LOWERED HEIGHT: 1/2"
- CAPACITY: 4,000 LBS.
- CONTROL IS FOOT SWITCH, 2 PEDAL, NEMA 1
- WITH MINIMUM USABLE 8' STRAIGHT CORD
- DURABLE LIQUID PANT BLUE FINISH
- EXTERNAL POWER UNIT

PLEASE CIRCLE SPECIFICATIONS:

POWER	<input checked="" type="checkbox"/> AC	<input type="checkbox"/> DC (12V)	<input type="checkbox"/> AIR/OIL
MOTOR VOLTAGE	<input type="checkbox"/> 115	<input type="checkbox"/> 208	<input checked="" type="checkbox"/> 230 <input type="checkbox"/> 460
DEDICATED CIRCUIT REQUIRED 60Hz			
MOTOR PHASE	<input type="checkbox"/> SINGLE	<input checked="" type="checkbox"/> THREE	
CONTROL	<input type="checkbox"/> HAND	<input checked="" type="checkbox"/> FOOT	

SPECIAL FEATURES
 NONE

A P P R O V A L

I, THE UNDERSIGNED, AGREE THAT THE PRODUCT AS REPRESENTED SATISFIES DESIGN AND DIMENSION REQUIREMENTS. I ALSO ACKNOWLEDGE MY DUTY TO CONFIRM PRODUCT AND INSTALLATION COMPLIANCE WITH ALL APPLICABLE FEDERAL, STATE AND LOCAL REGULATIONS AND STANDARDS.

UNITS REQUIRING APPROVAL DRAWINGS OR MODIFIED ARE NON-RETURNABLE

[] As drawn [] As marked

Signed: _____ Date: _____

Printed Name: _____

LEAD TIME WILL START UPON RECEIPT OF SIGNED APPROVAL DRAWING

DISTRIBUTOR'S NAME:		P.O.#
VESTIL MANUFACTURING		X
DRAWN BY: V.GONI		W.O.#
DATE: 08/27/2013		X
REFERENCE: X	SCALE: 1:32	SALES: X
QUOTED LEAD TIME: X	QUOTE # X	FILE NAME:
		04-007-055