

# GROUND LIFT SCISSOR TABLE - EHLTG-5250-4-36

APPROX WEIGHT: 1406.47 lbs.  
DOES NOT INCLUDE WEIGHT OF POWER OR PACKAGING!!!

\*\*\* ANY ADDITIONS, DELETIONS, OR OMISSIONS MUST BE CORRECTED ON THIS DRAWING AS THIS DRAWING WILL BE CONSIDERED ALL INCLUSIVE \*\*\*

ALL GRAPHICS PROVIDED ARE FOR REFERENCE ONLY. IF CERTAIN DIMENSIONS ARE CRITICAL PLEASE VERIFY THOSE DIMENSIONS WITH YOUR SALESPERSON

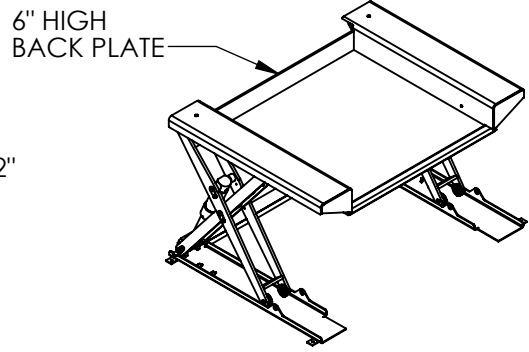
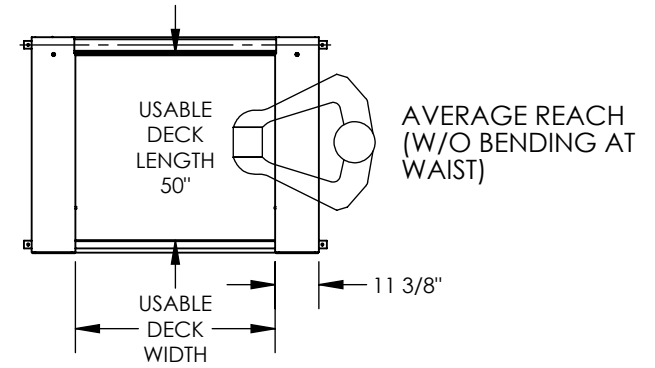
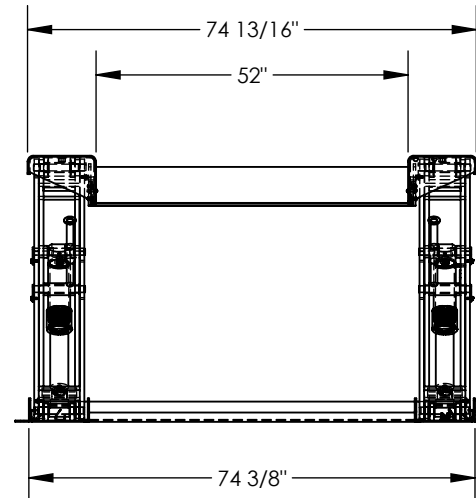
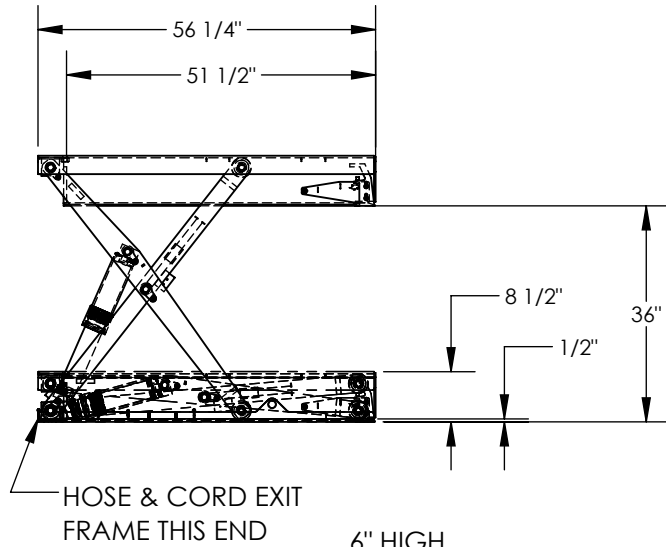

DECK TOLERANCE ± 1/2"  
TABLE HEIGHT TOLERANCE ± 1/2"  
DECK FLATNESS ± 1/4"

REMOTE POWER UNIT:  
32 1/2" x 12" x 12 1/2" (L x W x H)  
WITH 8' HOSE & CABLE

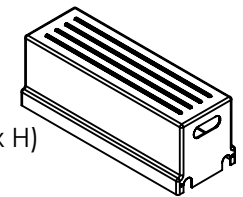

DIMENSION TOLERANCE ± 1/4"

## STANDARD FEATURES

- MODEL NUMBER IS EHLTG-5250-4-36
- PLATFORM USABLE LENGTH IS 50"
- PLATFORM USABLE WIDTH IS 52"
- PLATFORM RAISED MAX HEIGHT IS 36"
- PLATFORM LOWERED MIN HEIGHT IS 1/2"
- OVERALL LENGTH IS 56 1/4"
- OVERALL WIDTH IS 74 13/16"
- TABLE CAPACITY (EVENLY DISTRIBUTED) LOAD IS 4,000 LBS
- REMOTE POWER UNIT
  - 2 HP MOTOR (@ 3 PHASE)
  - 3/4 HP MOTOR (@ 1 PHASE)
- CONTROL IS FOOT SWITCH, 2 PEDAL, NEMA 1 WITH MINIMUM 8' USABLE STRAIGHT CORD
- SAFETY MAINTENANCE PROPS
- DISPLACEMENT STYLE CYLINDERS
- INSTALLED ROD DOWN
- EMERGENCY SAFETY STOP HYDRAULIC FUSE IN EACH CYLINDER
- UPPER TRAVEL LIMIT SWITCH
- ELECTRIC PINCH POINT GUARD
- UNITS HAVE 2' TEST LEAD AND PIG TAIL
- DURABLE LIQUID PAINT BLUE FINISH

## PLEASE CIRCLE SPECIFICATIONS:

POWER	<input checked="" type="checkbox"/> AC	<input type="checkbox"/> DC (12V)	<input type="checkbox"/> AIR/OIL
MOTOR VOLTAGE	<input type="checkbox"/> 115	<input type="checkbox"/> 200	<input checked="" type="checkbox"/> 460
DEDICATED CIRCUIT REQUIRED 60Hz			
MOTOR PHASE	<input type="checkbox"/> SINGLE	<input checked="" type="checkbox"/> THREE	
CONTROL	<input type="checkbox"/> HAND	<input checked="" type="checkbox"/> FOOT	

## SPECIAL FEATURES

NONE

I, THE UNDERSIGNED, AGREE THAT THE PRODUCT AS REPRESENTED SATISFIES DESIGN AND DIMENSION REQUIREMENTS. I ALSO ACKNOWLEDGE MY DUTY TO CONFIRM PRODUCT AND INSTALLATION COMPLIANCE WITH ALL APPLICABLE FEDERAL, STATE AND LOCAL REGULATIONS AND STANDARDS.

**UNITS REQUIRING APPROVAL DRAWINGS OR MODIFIED ARE NON-RETURNABLE**

[ ] As drawn [ ] As marked

Signed: \_\_\_\_\_ Date: \_\_\_\_\_

Printed Name: \_\_\_\_\_

LEAD TIME WILL START UPON RECEIPT OF SIGNED APPROVAL DRAWING

DISTRIBUTOR'S NAME:		P.O.#
VESTIL MANUFACTURING		X
DRAWN BY: V.GONI		W.O.#
DATE: 08/08/2013		X
REFERENCE: X	SCALE: 1:32	SALES: X
QUOTED LEAD TIME: ## WEEKS	QUOTE # X	FILE NAME: 04-007-053