

# GROUND LIFT SCISSOR TABLE - EHLTG-5284-3-54

APPROX WEIGHT: 2645.50 lbs.  
DOES NOT INCLUDE WEIGHT OF POWER OR PACKAGING!!!

\*\*\* ANY ADDITIONS, DELETIONS, OR OMISSIONS MUST BE CORRECTED ON THIS DRAWING AS THIS DRAWING WILL BE CONSIDERED ALL INCLUSIVE \*\*\*

ALL GRAPHICS PROVIDED ARE FOR REFERENCE ONLY. IF CERTAIN DIMENSIONS ARE CRITICAL PLEASE VERIFY THOSE DIMENSIONS WITH YOUR SALESPERSON

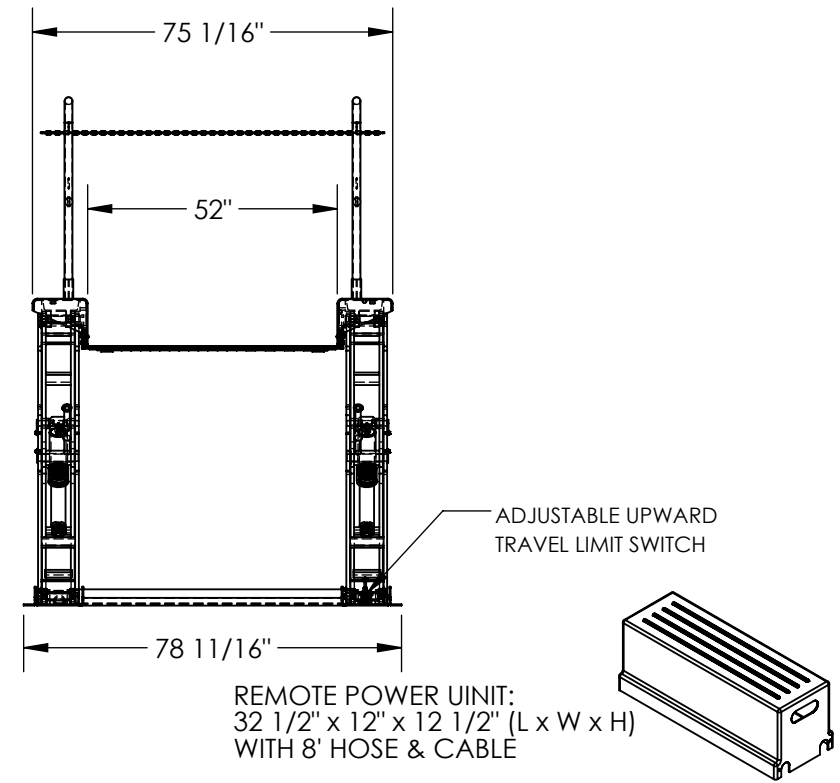
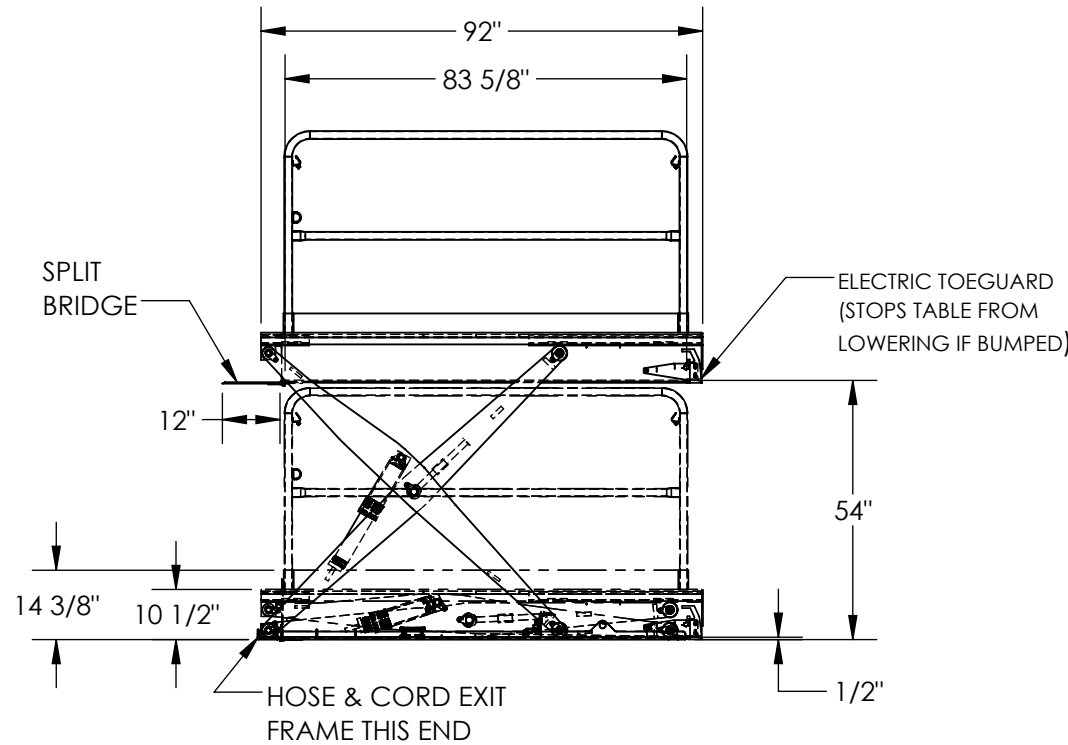

DIMENSION TOLERANCE  $\pm 1/4$ "

## STANDARD FEATURES

- MODEL NUMBER IS EHLTG-5284-3-54
- PLATFORM USABLE LENGTH IS 83 5/8"
- PLATFORM USABLE WIDTH IS 52"
- PLATFORM RAISED MAX HEIGHT IS 54"
- PLATFORM LOWERED MIN HEIGHT IS 1 1/2"
- OVERALL LENGTH IS 92"
- OVERALL WIDTH IS 78 11/16"
- 12" WIDE X 52" LONG SPLIT BRIDGE
- NON-REMOVABLE TOE BOARDS
- TABLE CAPACITY (EVENLY DISTRIBUTED)  
LOAD IS 3,000 LBS
- REMOTE POWER UNIT  
2 HP MOTOR (@ 3 PHASE)  
3/4 HP MOTOR (@ 1 PHASE)
- CONTROL IS FOOT SWITCH, 2 PEDAL, NEMA 1  
WITH MINIMUM 8' USABLE STRAIGHT CORD
- SAFETY MAINTENANCE PROPS
- DISPLACEMENT STYLE CYLINDERS  
INSTALLED ROD DOWN
- EMERGENCY SAFETY STOP HYDRAULIC FUSE  
IN EACH CYLINDER
- UPPER TRAVEL LIMIT SWITCH
- ELECTRIC PINCH POINT GUARD
- UNITS HAVE 2' TEST LEAD AND PIG TAIL
- DURABLE LIQUID PAINT BLUE FINISH WITH  
TOUGH BAKED IN POWDER COATED  
YELLOW FINISH REMOVABLE HAND RAILS

- DECK TOLERANCE  $\pm 1/2$ "
- TABLE HEIGHT TOLERANCE  $\pm 1/2$ "
- DECK FLATNESS  $\pm 1/4$ "

## PLEASE CIRCLE SPECIFICATIONS:

POWER	<input checked="" type="checkbox"/> AC	<input type="checkbox"/> DC (12V)	<input type="checkbox"/> AIR/OIL
MOTOR VOLTAGE	<input type="checkbox"/> 115	<input type="checkbox"/> 200	<input checked="" type="checkbox"/> 230
DEDICATED CIRCUIT REQUIRED 60Hz			
MOTOR PHASE	<input type="checkbox"/> SINGLE	<input checked="" type="checkbox"/> THREE	
CONTROL	<input type="checkbox"/> HAND		<input checked="" type="checkbox"/> FOOT

## SPECIAL FEATURES

NONE

I, THE UNDERSIGNED, AGREE THAT THE PRODUCT AS REPRESENTED SATISFIES DESIGN AND DIMENSION REQUIREMENTS. I ALSO ACKNOWLEDGE MY DUTY TO CONFIRM PRODUCT AND INSTALLATION COMPLIANCE WITH ALL APPLICABLE FEDERAL, STATE AND LOCAL REGULATIONS AND STANDARDS.

**UNITS REQUIRING APPROVAL DRAWINGS OR MODIFIED ARE NON-RETURNABLE**

[ ] As drawn [ ] As marked

Signed: \_\_\_\_\_ Date: \_\_\_\_\_

Printed Name: \_\_\_\_\_

LEAD TIME WILL START UPON RECEIPT OF SIGNED APPROVAL DRAWING

DISTRIBUTOR'S NAME:		P.O.#
VESTIL MANUFACTURING		X
DRAWN BY: JWW		W.O.#
DATE: 08/15/2019		X
REFERENCE: X	SCALE: 1:40	SALES: X
QUOTED LEAD TIME: ## WEEKS	QUOTE #	FILE NAME:
	N/A	04-007-114