

# SHORTY DOUBLE SCISSOR TABLE - EHLTSD-1628-1-35

APPROX WEIGHT: 178.68 lbs.  
DOES NOT INCLUDE WEIGHT OF POWER OR PACKAGING!!!

\*\*\* ANY ADDITIONS, DELETIONS, OR OMISSIONS MUST BE CORRECTED ON THIS DRAWING AS THIS DRAWING WILL BE CONSIDERED ALL INCLUSIVE \*\*\*

ALL GRAPHICS PROVIDED ARE FOR REFERENCE ONLY. IF CERTAIN DIMENSIONS ARE CRITICAL PLEASE VERIFY THOSE DIMENSIONS WITH YOUR SALESPERSON

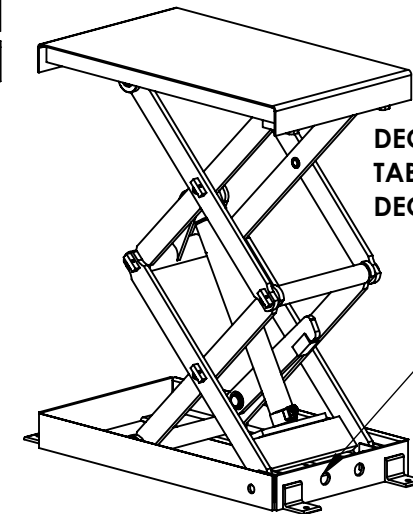
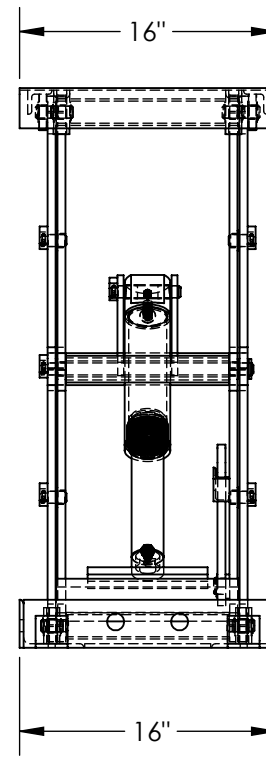
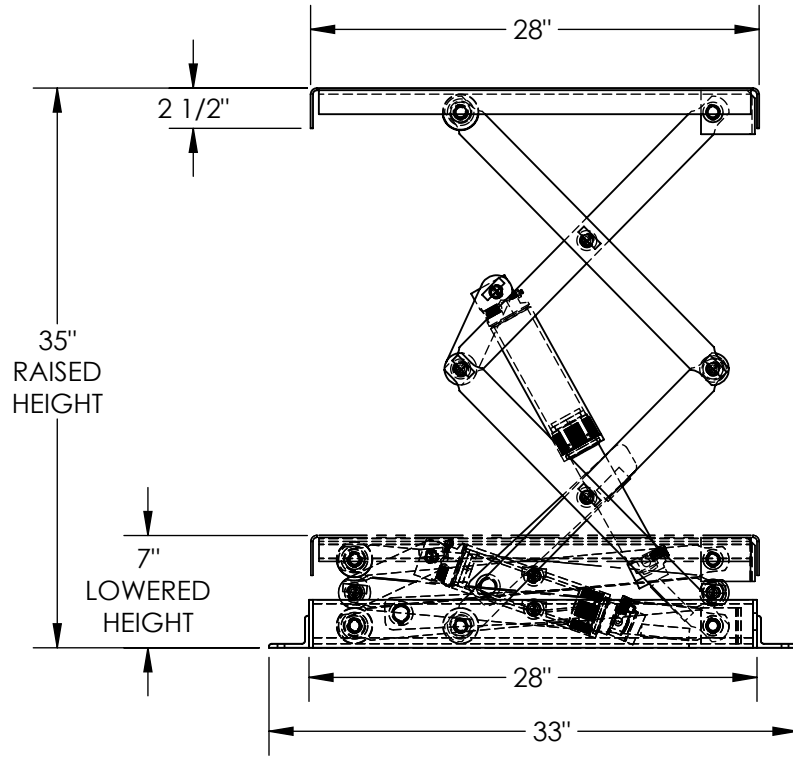

DECK TOLERANCE  $\pm 1/2"$   
TABLE HEIGHT TOLERANCES  $\pm 1/2"$   
DECK FLATNESS  $\pm 1/4"$

HOSE & CORD EXIT  
FRAME THIS END

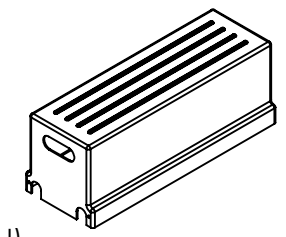

REMOTE POWER UNIT  
OVERALL DIMENSIONS  
32" x 12" x 12 1/2" (LG x W x H)

DIMENSION TOLERANCE  $\pm 1/4"$

## STANDARD FEATURES

- MODEL NUMBER IS EHLTSD-1628-1-35
- PLATFORM WIDTH IS 16"
- PLATFORM LENGTH IS 28"
- OVERALL WIDTH IS 16"
- OVERALL LENGTH IS 33"
- RAISED HEIGHT IS 35"
- LOWERED HEIGHT IS 7"
- CAPACITY (EVENLY DISTRIBUTED) IS 1,000 LBS
- 24V AC CONTROL VOLTAGE
- SAFETY MAINTENANCE PROPS
- DISPLACEMENT STYLE CYLINDERS
- INSTALLED ROD DOWN
- OTHER VOLTAGES HAVE A 2' TEST LEAD
- EXTERNAL POWER UNIT
- EMERGENCY SAFETY STOP HYDRAULIC FUSES
- UPPER TRAVEL LIMIT SWITCH
- DURABLE LIQUID PAINTED BLUE FINISH
- CONTROL IS HANDHELD, 2 BUTTON, NEMA 4
- PENDANT WITH MINIMUM 8' USABLE CORD
- AC 460 V, 3-PHASE, 60 HZ.

## SPECIAL FEATURES

NONE

### PLEASE CIRCLE SPECIFICATIONS:

POWER	AC	DC (12V)	AIR/OIL
MOTOR VOLTAGE	115	208	230 460
DEDICATED CIRCUIT REQUIRED			
MOTOR PHASE	SINGLE	THREE	
CONTROL	HAND	FOOT	

APPROVAL

I, THE UNDERSIGNED, AGREE THAT THE PRODUCT AS REPRESENTED SATISFIES DESIGN AND DIMENSION REQUIREMENTS. I ALSO ACKNOWLEDGE MY DUTY TO CONFIRM PRODUCT AND INSTALLATION COMPLIANCE WITH ALL APPLICABLE FEDERAL, STATE AND LOCAL REGULATIONS AND STANDARDS.

**UNITS REQUIRING APPROVAL DRAWINGS OR MODIFIED ARE NON-RETURNABLE**

[ ] As drawn [ ] As marked

Signed: \_\_\_\_\_ Date: \_\_\_\_\_

Printed Name: \_\_\_\_\_

LEAD TIME WILL START UPON RECEIPT OF SIGNED APPROVAL DRAWING

DISTRIBUTOR'S NAME:		P.O.#
VESTIL MANUFACTURING		X
DRAWN BY: CRA		W.O.#
DATE: 09/10/2019		X
REFERENCE: X	SCALE: 1:12	SALES: X
QUOTED LEAD TIME: X	QUOTE #	FILE NAME:
	X	26-007-216