

LIFT AND TILT SCISSOR TABLE - EHLTT-4848-4-47

APPROX WEIGHT: 1093 lbs.
DOES NOT INCLUDE WEIGHT OF POWER OR PACKAGING!!!

*** ANY ADDITIONS, DELETIONS, OR OMISSIONS MUST BE CORRECTED ON THIS DRAWING AS THIS DRAWING WILL BE CONSIDERED ALL INCLUSIVE ***

ALL GRAPHICS PROVIDED ARE FOR REFERENCE ONLY. IF CERTAIN DIMENSIONS ARE CRITICAL PLEASE VERIFY THOSE DIMENSIONS WITH YOUR SALESPERSON

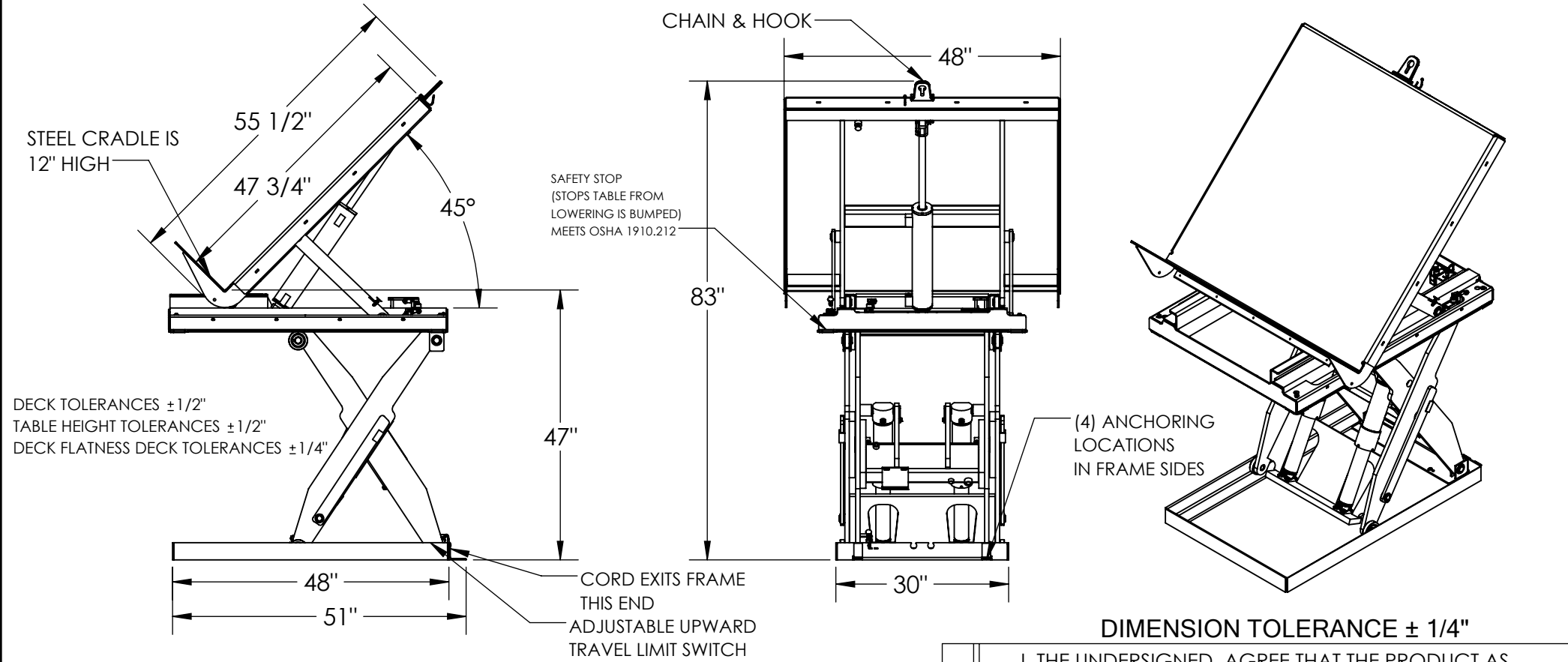

STANDARD FEATURES
 MODEL NUMBER: EHLTT-4848-4-47
 MAX. CAPACITY: 4,000 LBS
 FRAME WIDTH: 30"
 OVERALL LENGTH: 55 1/2"
 PLATFORM WIDTH: 48"
 PLATFORM LENGTH: 47 3/4"
 PLATFORM RAISED HEIGHT: 47"
 PLATFORM LOWERED HEIGHT: 11"
 OVERALL HEIGHT: 83"
 PLATFORM TILTS ON THE END OF THE LEG ASSEMBLY
 PLATFORM TILTING STYLE IS A SLIDE TILT
 Ø 1/4" X 60" CHAIN AND HOOK (NOT DRAWN TO SCALE)
 MAXIMUM TILT ANGLE IS 45°
 INTERNAL POWER UNIT
 CONTROL IS HANDHELD, 4 BUTTON, NEMA 4
 PENDANT WITH MINIMUM 8' USABLE COIL CORD
 DURABLE LIQUID PAINT BLUE FINISH

PLEASE CIRCLE SPECIFICATIONS:

POWER	AC	DC (12V)	AIR/OIL
MOTOR VOLTAGE	115	208	230 460
DEDICATED CIRCUIT REQUIRED 60Hz			
MOTOR PHASE	SINGLE	THREE	
CONTROL	HAND	FOOT	

SPECIAL FEATURES
NONE

A P P R O V A L

I, THE UNDERSIGNED, AGREE THAT THE PRODUCT AS REPRESENTED SATISFIES DESIGN AND DIMENSION REQUIREMENTS. I ALSO ACKNOWLEDGE MY DUTY TO CONFIRM PRODUCT AND INSTALLATION COMPLIANCE WITH ALL APPLICABLE FEDERAL, STATE AND LOCAL REGULATIONS AND STANDARDS.

UNITS REQUIRING APPROVAL DRAWINGS OR MODIFIED ARE NON-RETURNABLE

[] As drawn [] As marked

Signed: _____ Date: _____

Printed Name: _____

LEAD TIME WILL START UPON RECEIPT OF SIGNED APPROVAL DRAWING

DISTRIBUTOR'S NAME:		P.O.#
VESTIL MANUFACTURING		-
DRAWN BY: CRA		W.O.#
DATE: 07/22/2021		-
REFERENCE:	SCALE: 1:25	SALES: -
-	-	FILE NAME:
QUOTED LEAD TIME: -	QUOTE # -	02-007-331