

LIFT & TILT SCISSOR TABLE - EHLTTS-3654-4-48

APPROX WEIGHT: 1164.02 lbs.
DOES NOT INCLUDE WEIGHT OF POWER OR PACKAGING!!!

*** ANY ADDITIONS, DELETIONS, OR OMISSIONS MUST BE CORRECTED ON THIS DRAWING AS THIS DRAWING WILL BE CONSIDERED ALL INCLUSIVE ***

ALL GRAPHICS PROVIDED ARE FOR REFERENCE ONLY. IF CERTAIN DIMENSIONS ARE CRITICAL PLEASE VERIFY THOSE DIMENSIONS WITH YOUR SALESPERSON

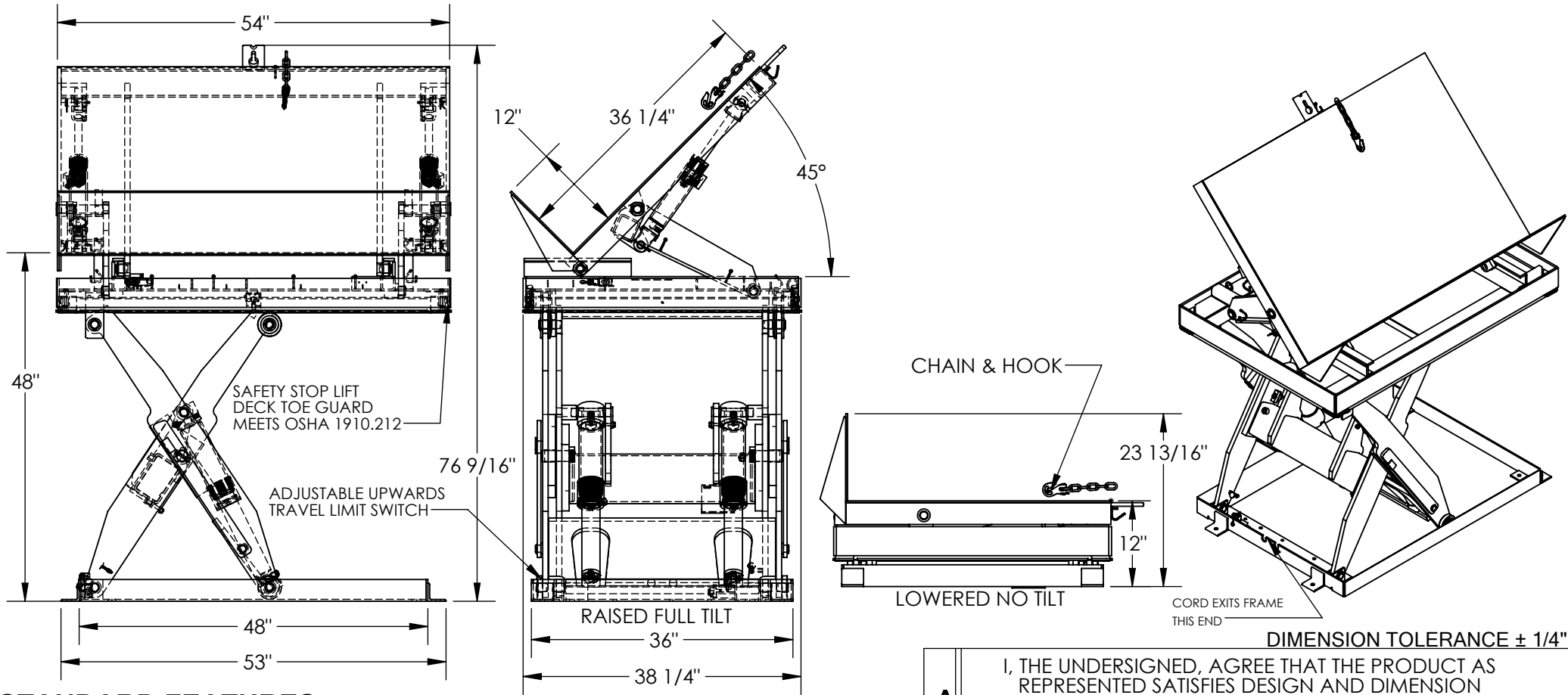

STANDARD FEATURES

- MODEL NUMBER IS EHLTTS-3654-4-48
- CAPACITY: 4,000 LBS W/ UNIFORM LOAD
- PLATFORM WIDTH IS 36 1/4"
- PLATFORM LENGTH IS 54"
- PLATFORM RAISED HEIGHT IS 48"
- PLATFORM LOWERED HEIGHT IS 12"
- MAXIMUM TILT ANGLE IS 45° SIDE LINK TILT
- OVERALL SIZE (W x L) IS 38 1/4" x 54"
- MAXIMUM HEIGHT IS 76 9/16"
- SAFETY MAINTENANCE PROPS
- DISPLACEMENT LIFT CYLINDER W/ DOWN VELOCITY FUSE
- DOUBLE ACTING TILT CYLINDERS W/ DOWN VELOCITY FUSE
- UNITS HAVE 2 FT TEST LEAD AND PG TAIL
- Ø1/4" x 60" CHAIN AND HOOK (NOT DRAWN TO SCALE)
- CONTROL IS HANDHELD, 4 BUTTON, NEMA 4
- PENDANT WITH MINIMUM 8' USABLE COIL CORD
- DURABLE LIQUID PAINT BLUE FINISH
- INTERNAL POWER UNIT

PLEASE CIRCLE SPECIFICATIONS:

POWER	<input checked="" type="checkbox"/> AC	<input type="checkbox"/> DC (12V)	<input type="checkbox"/> AIR/OIL
MOTOR VOLTAGE	<input type="checkbox"/> 115	<input type="checkbox"/> 200	<input checked="" type="checkbox"/> 230
DEDICATED CIRCUIT REQUIRED 60Hz			
MOTOR PHASE	<input type="checkbox"/> SINGLE	<input checked="" type="checkbox"/> THREE	
CONTROL	<input checked="" type="checkbox"/> HAND	<input type="checkbox"/> FOOT	

SPECIAL FEATURES

NONE

A P P R O V A L

I, THE UNDERSIGNED, AGREE THAT THE PRODUCT AS REPRESENTED SATISFIES DESIGN AND DIMENSION REQUIREMENTS. I ALSO ACKNOWLEDGE MY DUTY TO CONFIRM PRODUCT AND INSTALLATION COMPLIANCE WITH ALL APPLICABLE FEDERAL, STATE AND LOCAL REGULATIONS AND STANDARDS.

UNITS REQUIRING APPROVAL DRAWINGS OR MODIFIED ARE NON-RETURNABLE

[] As drawn [] As marked

Signed: _____ Date: _____

Printed Name: _____

LEAD TIME WILL START UPON RECEIPT OF SIGNED APPROVAL DRAWING

DISTRIBUTOR'S NAME:		P.O.#
VESTIL MANUFACTURING		X
DRAWN BY: BCN		W.O.#
DATE: 4/11/2017		X
REFERENCE: X	SCALE: 1:20	SALES: X
QUOTED LEAD TIME: X	QUOTE #	FILE NAME:
	X	02-007-221-001