

# EFFICIENCY MASTER TILT TABLE - EM1-500-4250-2

APPROX WEIGHT: 693.48 lbs.  
DOES NOT INCLUDE WEIGHT OF POWER OR PACKAGING!!!

\*\*\* ANY ADDITIONS, DELETIONS, OR OMISSIONS MUST BE CORRECTED ON THIS DRAWING AS THIS DRAWING WILL BE CONSIDERED ALL INCLUSIVE \*\*\*

ALL GRAPHICS PROVIDED ARE FOR REFERENCE ONLY. IF CERTAIN DIMENSIONS ARE CRITICAL PLEASE VERIFY THOSE DIMENSIONS WITH YOUR SALESPERSON

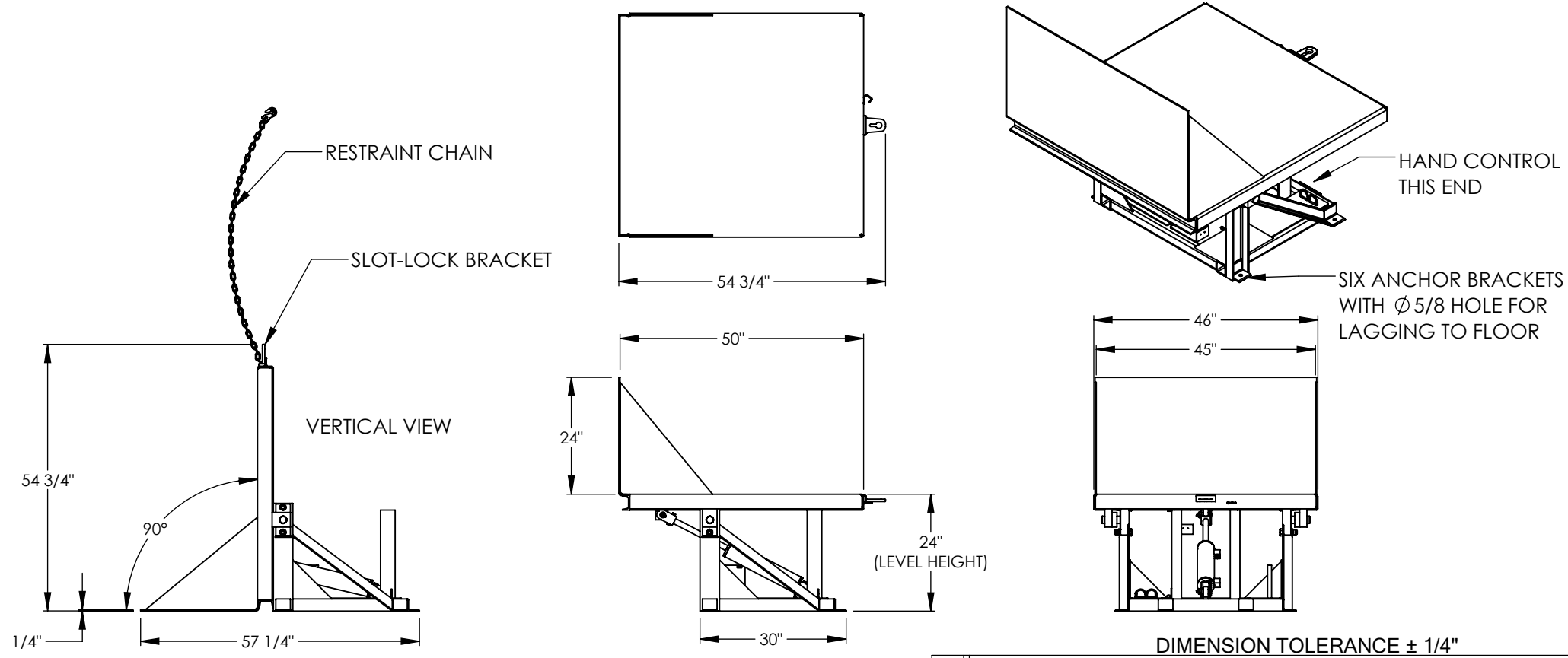

## STANDARD FEATURES

- MODEL NUMBER IS EM1-500-4250-2
- MAX CAPACITY IS 2,000 LBS (EVENLY DISTRIBUTED LOAD)
- USABLE DECK SIZE IS 42" WIDE x 50" LONG
- DECK LEVEL HEIGHT IS 24"
- OVERALL WIDTH IS 46"
- OVERALL LENGTH IS 57 1/4"
- OVERALL HEIGHT IS 54 3/4"
- MAX TILT ANGLE IS 90°
- SAFETY SLOT-LOCK RESTRAINT CHAIN BRACKET
- ALL STEEL CONSTRUCTION
- DURABLE LIQUID PAINT BLUE FINISH
- INTERNAL POWER UNIT
- HANDHELD PUSH BUTTON CONTROL W/8ft EXTENDED COIL CORD
- WARNING: CHECK STATE AND LOCAL CODES

## SPECIAL FEATURES

NONE

## 460V 3 PHASE AC POWER

CONTACT FACTORY FOR  
OTHER POWER OPTIONS

**APPROVAL**

I, THE UNDERSIGNED, AGREE THAT THE PRODUCT AS REPRESENTED SATISFIES DESIGN AND DIMENSION REQUIREMENTS. I ALSO ACKNOWLEDGE MY DUTY TO CONFIRM PRODUCT AND INSTALLATION COMPLIANCE WITH ALL APPLICABLE FEDERAL, STATE AND LOCAL REGULATIONS AND STANDARDS.

**UNITS REQUIRING APPROVAL DRAWINGS OR MODIFIED ARE NON-RETURNABLE**

As drawn       As marked

Signed: \_\_\_\_\_ Date: \_\_\_\_\_

Printed Name: \_\_\_\_\_

*LEAD TIME WILL START UPON RECEIPT OF SIGNED APPROVAL DRAWING*

DISTRIBUTOR'S NAME:		P.O.#
VESTIL MANUFACTURING		X
DRAWN BY: MTS		W.O.#
DATE: 11/17/2015		X
REFERENCE: X	SCALE: 1:30	SALES: X
QUOTED LEAD TIME: X	QUOTE #	FILE NAME:
	X	03-007-074