

EFFICIENCY MASTER TILT TABLE - EM1-500-4250-4

APPROX WEIGHT: 707.14 lbs.
 DOES NOT INCLUDE WEIGHT OF POWER OR PACKAGING!!!

*** ANY ADDITIONS, DELETIONS, OR OMISSIONS MUST BE CORRECTED ON THIS DRAWING AS THIS DRAWING WILL BE CONSIDERED ALL INCLUSIVE ***
 ALL GRAPHICS PROVIDED ARE FOR REFERENCE ONLY. IF CERTAIN DIMENSIONS ARE CRITICAL PLEASE VERIFY THOSE DIMENSIONS WITH YOUR SALESPERSON

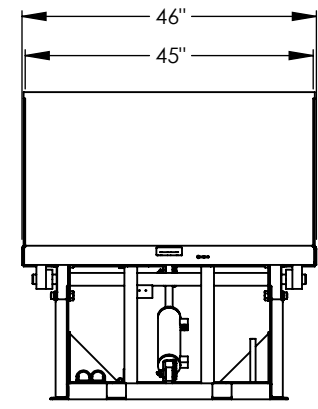
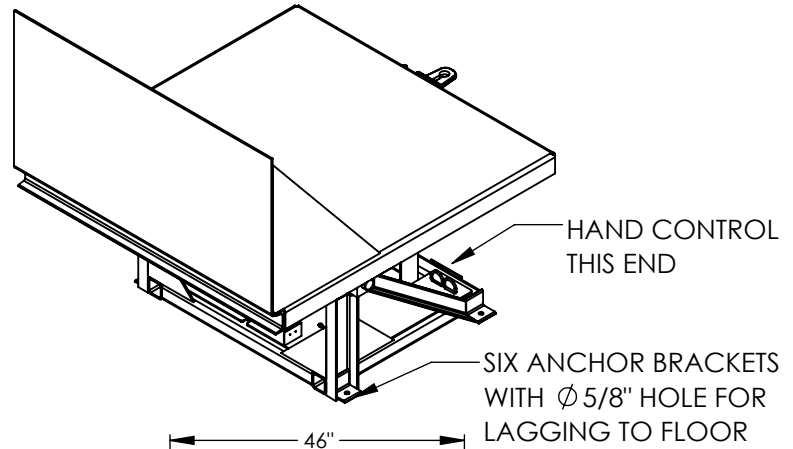
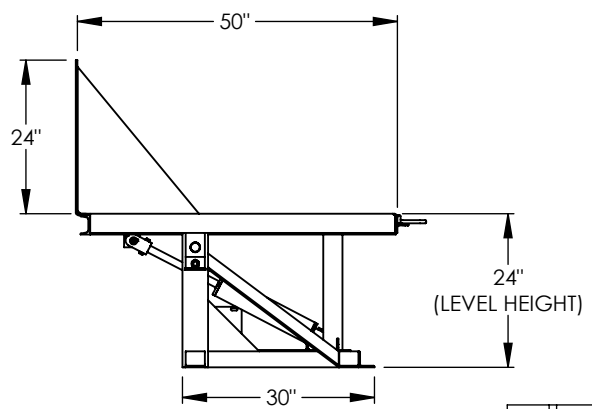
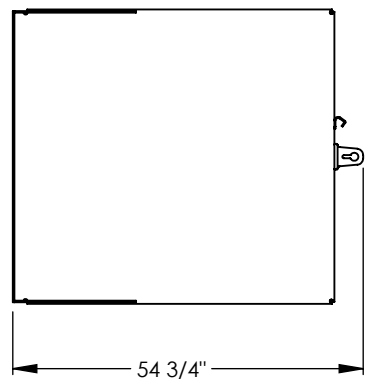
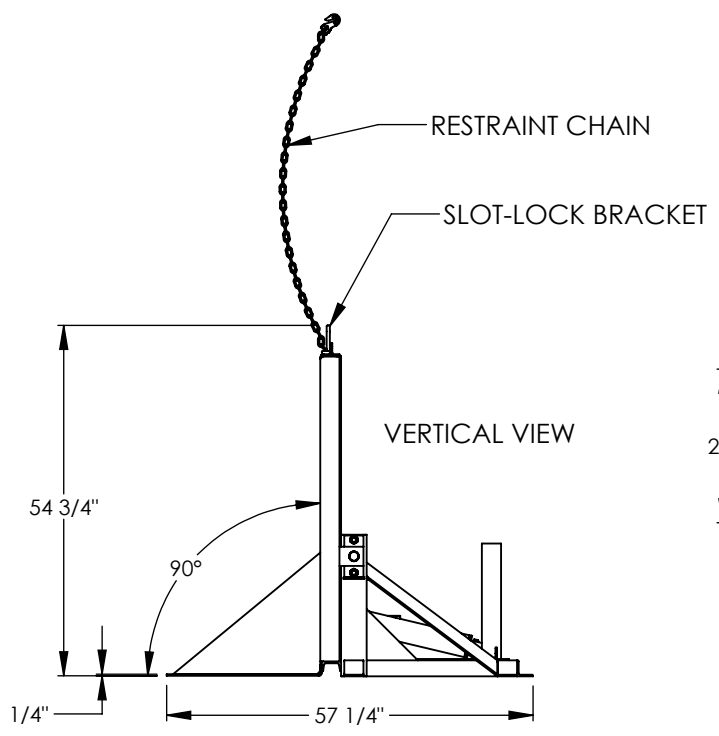

DIMENSION TOLERANCE ± 1/4"

STANDARD FEATURES

- MODEL NUMBER IS EM1-500-4250-4
- MAX CAPACITY IS 4,000 LBS (EVENLY DISTRIBUTED LOAD)
- USABLE DECK SIZE IS 42" WIDE x 50" LONG
- DECK LEVEL HEIGHT IS 24"
- OVERALL WIDTH IS 46"
- OVERALL LENGTH IS 57 1/4"
- OVERALL HEIGHT IS 54 3/4"
- MAX TILT ANGLE IS 90°
- SAFETY SLOT-LOCK RESTRAINT CHAIN BRACKET
- ALL STEEL CONSTRUCTION
- DURABLE LIQUID PAINT BLUE FINISH
- INTERNAL POWER UNIT
- HANDHELD PUSH BUTTON CONTROL W/ 8ft EXTENDED COIL CORD
- WARNING: CHECK STATE AND LOCAL CODES

SPECIAL FEATURES

NONE

460V 3 PHASE AC POWER

CONTACT FACTORY FOR
OTHER POWER OPTIONS

**A
P
P
R
O
V
A
L**

I, THE UNDERSIGNED, AGREE THAT THE PRODUCT AS REPRESENTED SATISFIES DESIGN AND DIMENSION REQUIREMENTS. I ALSO ACKNOWLEDGE MY DUTY TO CONFIRM PRODUCT AND INSTALLATION COMPLIANCE WITH ALL APPLICABLE FEDERAL, STATE AND LOCAL REGULATIONS AND STANDARDS.

UNITS REQUIRING APPROVAL DRAWINGS OR MODIFIED ARE NON-RETURNABLE

[] As drawn [] As marked

Signed: _____ Date: _____

Printed Name: _____

LEAD TIME WILL START UPON RECEIPT OF SIGNED APPROVAL DRAWING

DISTRIBUTOR'S NAME:		P.O.#
VESTIL MANUFACTURING		X
DRAWN BY: MTS	DATE: 11/17/2015	W.O.#
REFERENCE: X	SCALE: 1:30	X
QUOTED LEAD TIME: X	QUOTE #	SALES: X
	X	FILE NAME:
		03-007-075